

BID DOCUMENTS

HINESVILLE BUSINESS INCUBATOR SITE IMPROVEMENTS  
EDA PROJECT NO. 04-79-07284  
FOR  
HINESVILLE DEVELOPMENT AUTHORITY

JULY 6, 2021

Not for Bid



*SIMONTON ENGINEERING, LLC*

P.O. BOX 309  
HINESVILLE, GEORGIA 31310  
(912) 244-7800

1050 PARKSIDE COMMONS,  
SUITE 101  
GREENSBORO, GA 30642  
(706) 454-0870

SE NO. 2021-98

## TABLE OF CONTENTS

ADVERTISEMENT FOR BID

INSTRUCTIONS TO BIDDER

PROPOSAL

LAWFUL PRESENCE AFFIDAVIT

CONTRACTOR AFFIDAVIT

SUBCONTRACTOR AFFIDAVIT

CONTRACT

PAYMENT AND PERFORMANCE BOND

M/WBE REPORTING FORMS & INFORMATION

GENERAL CONDITIONS

SUPPLEMENTAL CONDITIONS

DAVIS BACON WAGE RATE

EDA DOCUMENTS

- Certificate Regarding Lobbying
- Notice of Requirement for Affirmative Action
- EDA Contracting Provision for Construction Projects

## TECHNICAL SPECIFICATIONS

SECTION 01001 GENERAL REQUIREMENTS

SECTION 01150\* MEASUREMENT AND PAYMENT

SECTION 02100 CLEARING AND GRUBBING

SECTION 02210 SITE GRADING

SECTION 02221 TRENCH EXCAVATION, BACKFILL  
AND COMPACTION

SECTION 02415 SITE DEMOLITION

SECTION 02520	STORM DRAINAGE AND APPURTENANCES
SECTION 02540	EROSION CONTROL
SECTION 02555	WATER DISTRIBUTION SYSTEM
SECTION 02560	NON-POTABLE REUSE WATER SYSTEM
SECTION 02611	BASE & PAVING
SECTION 02650	SANITARY SEWERS
SECTION 02821	GRASSING
SECTION 03300	CONCRETE, GENERAL

Not for Bid

## ADVERTISEMENT FOR BIDS

Sealed proposals will be received by the City of Hinesville Development Authority located at City Hall, 115 East ML King Jr. Drive, Hinesville, Georgia 31313 on July 28, 2021, until 2:00 (p.m) local time for Site improvements for the Hinesville Incubator Project.

The work to be performed consists of furnishing all labor and materials to complete the Hinesville Business Incubator. More specifically, the project will consist of site improvements to include grading, base & pavement plus utilities.

Plans, Specifications, and Contract documents are open to public inspection at the City of Hinesville, The City Website, Dodge Data and Analytics, ConstructConnect, and Simonton Engineering, LLC, Hinesville, Georgia. Copies of the Plans, Specifications, and Contract Documents may be obtained by contacting Simonton Engineering, LLC, P.O. Box 309, Hinesville, Georgia 31313, (912) 244-7800, and by depositing a non-refundable Fifty & no/100 (\$50) for each set of plans requested.

Each Contractor must prequalify for bid by submitting a completed "Statement of Bidder Qualifications" form supplied by the Engineer. Bids will be accepted from prequalified bidders only.

Bids must be accompanied by a certified check or bid bond in an amount equal to at least five percent (5%) of total amount bid for the completed work.

No bids may be withdrawn for a period of sixty (60) days after the closing time schedule for receipt of bids.

The Owner reserves the right to accept or reject any or all bids and to waive informalities. Award of the contract, if it is awarded, will be to the lowest responsible bidder.

NOTE: Plans and Specifications must be obtained no later than five (5) working days before the bid date. No exceptions.

## INSTRUCTIONS TO BIDDER

### 1. SUBMISSION OF PROPOSALS:

- A. Sealed proposals will be received by The City of Hinesville Development Authority at the City Hall, 115 East ML King Jr. Drive, Hinesville, Georgia 31313 until 2:00 (p.m.) local time, on July, 28, 2021 for all labor and materials required to fully complete the work identified in the plans and specifications for site work for the Business Incubator Project.
- B. At the time and place noted above, the proposals will be publicly opened and read aloud.
- C. The proposal (including Statement of Bidder's Qualifications) shall be submitted **in duplicate** on an exact copy of the proposal form bound herein. Both copies of the Proposal Form must be signed. All blank spaces on the forms shall be filled in and all information called for shall be provided. The terms "NO BID" may be used to fill in a blank space on the Proposal Form. All signatures shall be in ink and in longhand, and the completed forms shall be without alterations or corrections; any interlineations must be initialed by the Bidder.
- D. Failure to submit a proposal in the form requested or the inclusion of any alternates, conditions, limitations or provisions not called for, will render the bid irregular and shall be considered sufficient cause for rejection of the bid.
- E. Proposal shall be in opaque, sealed envelope and marked "Incubator Site Work" and shall bear the name of the Bidder. Proposal is to reach the above address no later than the hour and date named above, or authorized extension thereof. No proposal will be received after that time.
- F. Proposals, together with the full bid bond, may be withdrawn by Bidders prior to the time set for official opening. After time has been called, no proposal may be withdrawn for a period of sixty (60) days after the time and date of the opening.

### 2. INTERPRETATIONS:

- A. Neither Owner nor Engineer will be responsible for any oral instructions or interpretations of the Drawings and Specifications.
- B. Requests for interpretations of Drawings and Specifications must be made in writing to the Engineer no later than seven (7) days prior to date set for receipt of bids, and failure on the part of the successful bidder to do so shall not relieve him as Contractor of the obligation to execute such work in accordance with a later interpretation by the Engineer.
- C. All interpretations made to bidders will be issued in the form of an addendum to the Plans and Specifications will be sent to all bidders. The requirements of such

an addendum are to be included in the bids, and in closing the contract, the addenda will become a part thereof.

3. BASIS OF CONTRACT AWARD:

- A. The competency and responsibility of a bidder will be considered in making the award. Owner does not obligate himself to accept the lowest bid or any other bid.
- B. The Owner reserves the right to reject any or all proposals and to waive any technicalities.

4. FORMS AND BONDS:

- A. The Bidder's attention is directed to the Proposal Form and the Performance and Labor and Materials Payment Bond section.
- B. The bond shall be accompanied with the agents and underwriters name, address and telephone number.
- C. The project shall require 100% Performance and Payment Bond

5. INSPECTING AND TESTING OF MATERIALS:

- A. Whenever, in these Contract Documents, inspecting, testing, or certification of material(s) is called for, the selection of bureaus, laboratories and/or agencies for such inspecting and testing shall be made by an Independent Testing Laboratory and the character of the test shall be stipulated by the Engineer. Documentary evidence satisfactory to the Engineer that the materials have passed the required inspection and test must be furnished in quadruplicate to the Engineer by the bureau, agency, or laboratory selected. Materials satisfactorily meeting the requirements of the inspection or tests shall be approved by the Engineer and the Contractor notified of the results. The cost of such inspecting and testing shall be paid for by the Contractor.

6. CONSTRUCTION SCHEDULE:

- A. The Contractor will be required to submit a construction schedule in writing identifying milestones and completion dates at the preconstruction conference. He shall also be required to submit a resume' of the proposed job superintendent for approval by the Engineer.

7. INSURANCE:

- A. The Contractor's attention is directed to Article 11 of the Supplemental General Conditions, "Insurance." He should review these requirements and be prepared to submit insurance certificates providing the coverage identified. On the insurance

certificates, the "Certificate Holder" should be listed as **both** the Owner and P.C. Simonton and Associates, Inc.

8. CONSTRUCTION STAKING:

- A. The Owner will provide horizontal and vertical control. The Contractor will be responsible for construction staking.

9. UTILITY CONTRACTOR LICENSING LAW:

- A. Effective December 31, 1993, a new law took effect which has an indirect effect on engineers. As of that date all utility contractors must be licensed; a utility contractor is anyone who digs 5 feet or deeper on a public or private project and where the cost of work exceeds \$100,000.
- B. Effective July 1, 2004 the law was modified where the cost of work has no dollar amount therefore anyone who digs 5 feet or deeper on a public or private project must have a utility license.
- C. "It shall be unlawful for any person to contract with any other person for the performance of utility contracting work who is known by such person to not have a current, valid license as a utility contractor pursuant to this chapter." (O.C.G.A. 43-14-8.2(h)) Bids or proposals for utility contracting work will NOT be opened or considered unless the Utility Contractor License number is written on the face of the bid or proposal.

10. MULTIPLE MOBILIZATIONS:

- A. The Contractor will be required to perform the work on this project in three phases.
- B. The first phase will be to clear the site, demolition of existing facilities, initial grading to include the building pad and access for the building contractor, driveway drainage, water & sewer connections and initial erosion & sediment control.
- C. Intermediate mobilizations may be required for maintenance of erosion and sediment control BMPs.
- D. The final mobilization will be to complete grading, correct damage to grading by the building contractor, installation of base and pavement, parking lot striping, final drainage work to include the retention pond grading and operational requirements.

11. FEDERAL PARTICIPATION DISCLOSURE

- A. This project will be partially funded with federal funds for the United States Department of Commerce, Economic Development Administration and therefore is subject to the federal laws and regulations associated with the program.

12. Mobilization

- A. The Economic development Administration has set August 7, 2021, as the deadline to begin construction. It is anticipated that the bid award will be given to the contractor by July 30, 2021, and the contractor will be required to provide bonds and have contracts executed to allow him to mobilize to the project by August 7, 2021. Mobilization may be validated by the establishment of the contractor onsite by installation of silt fence, construction exit or equipment on site to begin demolition.

Not for Bid



PROPOSAL

Hinesville Development Authority  
115 East ML King Jr. Drive,  
Hinesville, GA. 31313

Submitted: \_\_\_\_\_, \_\_\_\_\_

The undersigned, as Bidder, hereby declares that the only person or persons interested in the Proposal as principal or principals is or are named herein and that no other person that herein mentioned has any interest in this Proposal or in the contract to be entered into; that this Proposal is made without connection with any other person, company or parties making a bid or Proposal; and that it is in full respect fair and in good faith without collusion or fraud.

The Bidder further declares that he has examined the site of the work and informed himself fully in regard to all conditions pertaining to the place where the work is to be done; that he has examined the Plans and Specifications for the work and Contractual Documents relative thereto, and has read all Special Provisions and General Conditions furnished prior to the opening of bids; that he has satisfied himself relative to the work to be performed.

The Bidder proposes and agrees, if the Proposal is accepted, to contract with \_\_\_\_\_ The Hinesville Development Authority in the form of contract specified, to furnish all necessary materials, equipment, machinery, tools, apparatus, means of transportation and labor necessary to complete the construction of the work, in full and in complete accordance with the shown, noted, described, and reasonably intended requirements of the Specifications and Contract Documents, to the full and entire satisfaction of The Hinesville Development Authority with a definite understanding that no money will be allowed for extra work except as set forth in the attached General Conditions and Contract Documents, for prices on the following pages.

**Hinesville Business Incubator  
EDA Project No. 04-79-07284  
Bid Items  
for  
Hinesville Development Authority  
SE No. 2021-98**

<b>Item No.</b>	<b>Estimated Quantity</b>	<b>Units</b>	<b>Description</b>	<b>Unit Price</b>	<b>Total Price</b>
1	1	LS	Clearing & Demolition		\$
2	1	LS	Site Grading		\$
3	336	SY	Sidewalk	\$	\$
4	1,350	SY	6" Crusher Run Base	\$	\$
5	1300	SY	2" 12.5MM Paving	\$	\$
6	8	EA	Parking Bumpers	\$	\$
7	1	LS	Parking Lot Striping		\$
8	350	LF	8" PVC Drain	\$	\$
9	1	EA	ADS Yard Inlet		\$
10	125	LF	15" RCP	\$	\$
11	2	EA	15" Safety End Section	\$	\$
12	1	LS	Regrade Roadside Ditch		\$
13	1	LS	Retention Area Complete		\$
14	120	LF	Tree Protection Fence	\$	\$
15	1250	LF	"NS" Silt Fence	\$	\$
16	1	EA	Construction Exit	\$	\$
17	1	LS	Temporary Grassing		\$
18	1	LS	Permanent Grassing		\$
19	1	LS	Planting & Irrigation		\$
20	1	LS	2" X 2" Water Connection		\$
22	1	EA	2" BFP		\$
25	80	LF	2" Water Main	\$	\$
27	1	LS	Conn to Existing Sewer		\$
28	110	LF	4" Sewer Service	\$	\$
29	2	EA	4" Clean Outs	\$	\$
30	50	SY	Rip Rap Outlet Protection	\$	\$
31	1	LS	Mobilization		\$
<b>TOTAL SITE COST</b>					\$

The Bidder further proposes and agrees hereby to commence work under his Contract, with adequate force and equipment, on a date to be specified in written order of the ENGINEER and shall fully complete all work hereunder within Two Hundred Forty ( 240 ) consecutive days from and including said date.

The Bidder declares that he understands that the quantities shown for unit price items, are approximate only, are valid only upon written authorization of the ENGINEER, and are subject to either increase or decrease and that should the quantities of any items of work be increased, the Bidder proposes to do the additional at the unit prices stated herein; and should the quantities be decreased, the Bidder also understands that payment will be made on the basis of actual quantities at the unit price bid and will make no claim for anticipated profits for any decrease in quantities, and that actual quantities will be determined upon completion of the work, at which time adjustment will be made to the Contract amount by direct increase or decrease.

The undersigned further agrees that, in case of failure on his part to execute the Construction Contract and the bond within ten (10) consecutive calendar days after written notice being given of the award of the Contract, the check or bond accompanying this bid, and the monies payable thereon, shall be paid into the funds of the \_\_\_\_\_ as liquidated damages for such failure, otherwise the check or bid bond accompanying this proposal shall be returned to the undersigned.

Attached hereto is a certified check on the \_\_\_\_\_ Bank of \_\_\_\_\_ or a Bid Bond by the \_\_\_\_\_ in the amount of \_\_\_\_\_ Dollars (\$ \_\_\_\_\_ ) made payable to the \_\_\_\_\_, in accordance with the conditions of the advertisement and provisions herein.

Submitted:

\_\_\_\_\_

By:

\_\_\_\_\_

Title:

\_\_\_\_\_

Bidders Address: \_\_\_\_\_

City, State, Zip Code: \_\_\_\_\_

Telephone Number: \_\_\_\_\_

Bonding Agent: \_\_\_\_\_

Physical Address: \_\_\_\_\_

Telephone Number: \_\_\_\_\_

Underwriters Name: \_\_\_\_\_

Physical Address: \_\_\_\_\_

Telephone Number: \_\_\_\_\_

FAILURE TO COMPLETE THIS SECTION IS GROUNDS FOR REJECTION

BIDDER ACKNOWLEDGES RECEIPT OF THE FOLLOWING ADDENDUM:

No. \_\_\_\_\_ Date \_\_\_\_\_ No. \_\_\_\_\_ Date \_\_\_\_\_

No. \_\_\_\_\_ Date \_\_\_\_\_ No. \_\_\_\_\_ Date \_\_\_\_\_

#### EXPERIENCE AND REFERENCES

The Bidder shall state what work he had done (minimum of three) of similar nature to that bid for, and give references that will afford the Owner opportunity to judge as to experience, skill, business standing and financial ability. Failure to complete this section is grounds for rejection.

## LAWFUL PRESENCE AFFIDAVIT

Pursuant to O.C.G.A. § 50-36-1, all persons who - either on behalf of themselves or on behalf of an individual, business, corporation, partnership, or other private entity - apply for certain public benefits must (1) be eighteen years of age or older and (2) submit an affidavit that they are lawfully present in the United States. Public benefits, as defined by O.C.G.A. § 50-36-1(a)(3)(A), include any grant, contract, loan, professional license, or commercial license provided by an agency of State or local government or by appropriated funds of a State or local government.

I, \_\_\_\_\_, swear or affirm under penalty of perjury under the laws of the State of Georgia that I am 18 years of age or older and (check one):

\_\_\_ I am a United States citizen, or

\_\_\_ I am a legal Permanent Resident of the United States, or

\_\_\_ I am a qualified alien (other than as a permanent resident) or nonimmigrant in the United States pursuant to Federal law.

The secure and verifiable document provided with this affidavit can best be classified as:

\_\_\_\_\_

I understand that this sworn statement is required by law because I have applied for a public benefit and/or a business license on my behalf as an individual or on behalf of a business, corporation, partnership, or other private entity. I understand that state law required me to provide proof that I am lawfully present in the United States prior to receipt of this public benefit as listed above. I further acknowledge that making a false, fictitious, or fraudulent statement or representation in this sworn affidavit is punishable under the criminal laws of Georgia under O.C.G.A. § 16-10-20 and it shall constitute a separate criminal offense each time a public benefit is fraudulently received.

Signature \_\_\_\_\_

Date \_\_\_\_\_

Title \_\_\_\_\_

\*Alien Registration # for Non-citizens \_\_\_\_\_

Business Name \_\_\_\_\_

TIN or SSN \_\_\_\_\_

*If this affidavit is not presented in person, applicant must submit a notarized copy of this affidavit.*

Notarized this \_\_\_ Day of \_\_\_\_\_, in the State of \_\_\_\_\_,

County of \_\_\_\_\_

Notary \_\_\_\_\_

Commission Expires \_\_\_\_\_

\*Note: O.C.G.A § 50-36-1(e) (2) requires that aliens under the Federal Immigration and Nationality Act., Title 8 U.S.C., as amended, provide their alien registration number. Because legal permanent residents are included in the federal definition of "alien", legal permanent residents must also provide their alien registration number. Qualified aliens that do not have an alien registration number may supply another identifying number below:

Another Identifying Number \_\_\_\_\_

**Contractor Affidavit under O.C.G.A. § 13-10-91(b)(1)**

By executing this affidavit, the undersigned contractor verifies its compliance with O.C.G.A. §13-10-91, stating affirmatively that the individual, firm or corporation which is engaged in the physical performance of services on behalf of \_\_\_\_\_ has registered with, is authorized to use and uses the federal work authorization program commonly known as E-verify, or any subsequent replacement program, in accordance with the applicable provisions and deadlines established in O.C.G.A. § 13-10-91. Furthermore, the undersigned contractor will continue to use the federal work authorization program throughout the contract period and the undersigned contractor will contract for the physical performance of services in satisfaction of such contract only with subcontractors who present an affidavit to the contractor with the information required by O.C.G.A. § 13-10-91(b). Contractor hereby attests that its federal work authorization user identification number and date of authorization are as follows:

\_\_\_\_\_  
Federal Work Authorization User Identification Number/E-verify User Number

\_\_\_\_\_  
Date of Authorization/Date of contract between Contractor and Public Employer

\_\_\_\_\_  
Legal Name of Contractor (please print)

\_\_\_\_\_  
Legal Address of Contractor

\_\_\_\_\_  
City, State, & Zip Code

\_\_\_\_\_  
Name of Project

\_\_\_\_\_  
Name of Public Employer

I hereby declare under penalty of perjury that the foregoing is true and correct.

Executed on \_\_\_\_\_ of \_\_\_\_\_, 20\_\_ in \_\_\_\_\_ (city), \_\_\_\_\_ (state).

\_\_\_\_\_  
Signature of Authorized Officer or Agent

\_\_\_\_\_  
Printed Name and Title of Authorized Officer or Agent

SUBSCRIBED AND SWORN BEFORE ME ON THIS \_\_\_\_\_ DAY OF \_\_\_\_\_, 20\_\_.

\_\_\_\_\_  
Notary Public

\_\_\_\_\_  
Commission Expires

**Subcontractor Affidavit under O.C.G.A. § 13-10-91(b)(3)**

By executing this affidavit, the undersigned subcontractor verifies its compliance with O.C.G.A. § 13-10-91, stating affirmatively that the individual, firm or corporation which is engaged in the physical performance of services under a contract with \_\_\_\_\_ (name of contractor) on behalf of \_\_\_\_\_ has registered with, is authorized to use and uses the federal work authorization program commonly known as E-Verify, or any subsequent replacement program, in accordance with the applicable provisions and deadlines established in O.C.G.A. § 13-10-91. Furthermore, the undersigned subcontractor will continue to use the federal work authorization program throughout the contract period and the undersigned subcontractor will contract for the physical performance of services in satisfaction of such contract only with sub-subcontractors who present an affidavit to the subcontractor with the information required by O.C.G.A. § 13-10-91(b). Additionally, the undersigned subcontractor will forward notice of the receipt of an affidavit from a sub-subcontractor to the contractor within five business days of receipt. If the undersigned subcontractor receives notice of receipt of an affidavit from any sub-subcontractor that has contracted with a sub-subcontractor to forward, within five business days of receipt, a copy of such notice to the contractor. Subcontractor hereby attests that its federal work authorization user identification number and date of authorization are as follows:

\_\_\_\_\_  
Federal Work Authorization User Identification Number

\_\_\_\_\_  
Date of Authorization

\_\_\_\_\_  
Name of Subcontractor

\_\_\_\_\_  
Name of Project

\_\_\_\_\_  
Name of Public Employer

I hereby declare under penalty of perjury that the foregoing is true and correct.

Executed on \_\_\_\_\_, \_\_\_, 201\_\_ in \_\_\_\_\_ (city), \_\_\_\_\_ (state).

\_\_\_\_\_  
Signature of Authorized Officer or Agent

\_\_\_\_\_  
Printed Name and Title of Authorized Officer or Agent

SUBSCRIBED AND SWORN BEFORE ME ON THIS THE \_\_\_ DAY OF \_\_\_\_\_, 20\_\_.

\_\_\_\_\_  
NOTARY PUBLIC

My Commission Expires:  
\_\_\_\_\_

CONTRACT

THIS AGREEMENT, made this \_\_\_\_\_ day of \_\_\_\_\_, 20\_\_, by and between \_\_\_\_\_, herein called "OWNER" acting herein through \_\_\_\_\_ and \_\_\_\_\_, of \_\_\_\_\_, County of \_\_\_\_\_, and State of \_\_\_\_\_, herein called "CONTRACTOR".

WITNESSETH: that for and in consideration of the payments and agreement hereinafter mentioned, to be made and performed by the OWNER, and the CONTRACTOR hereby agrees with the OWNER to commence and complete the construction described as follows:

HINESVILLE BUSINESS INCUBATOR SITE IMPROVEMENTS

EDA PROJECT NO. 04-79-07284

FOR

HINESVILLE DEVELOPMENT AUTHORITY

hereinafter called the project, for the sum of \_\_\_\_\_ Dollars (\$\_\_\_\_\_) and all extra work in connection therewith, under the terms as stated in the General and Special Conditions of the Contract; and at his (its or their) own proper cost and expense to furnish all the materials, supplies, machinery, equipment, tools, superintendence, labor, insurance, and other accessories and services necessary to complete the said project in accordance with the conditions and prices stated in the Proposal; the General Conditions, Supplemental General Conditions and Special Conditions of the Contract, the plans, which include all maps, plats, blue prints and other drawings and printed or written explanatory matter thereof, the specifications and Contract Documents therefore as prepared by Simonton Engineering, LLC, herein entitled the ENGINEER, and as enumerated in Paragraph 1 of the Supplementary General Conditions, all of which are made a part hereof and collectively evidence and constitute the Contract.



The Contractor hereby agrees to commence work under this Contract on or before a date to be specified in a written "Notice to Proceed" from the Owner and to fully complete the project within Two Hundred Forty ( 240 ) consecutive calendar days thereafter.

The Contractor further agrees to pay, as liquidated damages, the sum of \$300 for each consecutive calendar day thereafter as hereinafter provided in Section 01001, Paragraph 1.11.

The owner agrees to pay the contractor in current funds for the past performance of the contract subject to additions and deductions as provided in the General Conditions, Article 14 of the contract. Retainage on progress payments shall be ten (10) percent until the project is substantially complete (80% or more) at which point retainage may be reduced to 5% depending on the contractor's progress related to schedule and workmanship.

Not for Bid

IN WITNESS WHEREOF, the parties present have executed this contract in four (4) counterparts, each of which shall be deemed an original, in the year and day first above mentioned.

ATTEST

\_\_\_\_\_  
(Owner)

By \_\_\_\_\_

\_\_\_\_\_  
(Secretary)

\_\_\_\_\_  
(Witness)

\_\_\_\_\_  
(Title)

\_\_\_\_\_  
(Contractor)

By \_\_\_\_\_

\_\_\_\_\_  
(Secretary)

\_\_\_\_\_  
(Witness)

\_\_\_\_\_  
(Title)

\_\_\_\_\_  
(Address and Zip Code)

Not for Bid

PERFORMANCE BOND AND LABOR AND MATERIAL PAYMENT BOND

1. REFERENCE

By reference, "The Performance Bond and Payment Bond", E.J.C.D.C. Document C-610 and C-615, 2007 Edition, pages 1 through 2 of each inclusive, is a part of this Contract.

Not for Bid



## M/WBE PARTICIPATION REPORT

### INSTRUCTIONS TO CONTRACTOR/CONSULTANT

To receive credit toward contracted M/WBE goals, the Prime Contractor/Consultant must complete and submit this form with each Request for Periodic Payment beginning with the first payment request. An additional copy of this section must be submitted to the M/WBE Consultant. The M/WBE Consultant may be contacted by phone at (912) 368.3471 or by fax at (912) 368.3420. **Failure to submit this form may result in no credit toward the contract M/WBE requirements and a delay in monthly progress payment.**

1. Project Name: The official name of the project as stated on the contract
2. Date: Date Report is being submitted
3. Report Number: Reports must be consecutively numbered.
4. Contract Amount: Total amount of the contract to be paid to the Prime Contractor/Consultant by the City of Hinesville for completion of the project.
5. M/WBE Goals: Enter the contracted MBE, WBE, and M/WBE Goals per the signed agreement.
6. Final Project Report: Place an "X" or checkmark in this box when the project has been completed and the report submitted is the final payment report. Enter the date of project completion.
7. M/WBE Information: ONLY M/WBEs that have been verified and approved by the City of Hinesville M/WBE Consultant, from the Prime Contractor's/Consultant's "Proposed Schedule of M/WBE Participation" may be included on the payment report. NO SUBSTITUTIONS OR CHANGES IN GOALS MAY BE MADE without prior written approval by the City M/WBE Consultant.
8. M/WBE Payments: Enter the actual amount of the subcontract agreement for each approved M/WBE, the date of any payments occurring within the report period, the amount of the payments to each M/WBE during this period and the total each M/WBE has been paid-to-date.
9. Earnings-to-date: Enter the total amount paid to date to minority-owned business (MBE) subcontractors, non-minority women-owned business (WBE) subcontractors, and the combined total to all M/WBE subcontractors.
10. Contractor Certification: The contractor or his authorized representative must sign this form prior to submittal. Signature indicates that all information is true and correct and documented proof of all information is on file and available for City of Hinesville review at any time.

### GENERAL INFORMATION

**The prime contractor/consultant may not change M/WBE firms without prior written approval of the City of Hinesville M/WBE Consultant. Approval cannot be obtained from the City's Engineer, or other City of Hinesville employees. Contractors/Consultants must use the Add/Change of M/WBE Subcontractor Form to request changes to the Proposed Schedule of M/WBE Participation. Any proposed changes must meet established M/WBE goals and conform to contract regulations and M/WBE Program Requirements.**

If the prime contractor/consultant in its bid/proposal included any second or lower tier subcontractor/sub-consultant/supplier towards meeting the goal, it is the sole responsibility of the prime contractor/consultant to ensure all M/WBE firms have been reviewed and approved by the City of Hinesville and to document all subcontracting/sub-consulting and/or supplier participation dollars counted towards the goal, irrespective of tier level. Upon completion of the work, a final "M/WBE Participation Report" will be required and submitted with the final pay request and MWBE Office.

As per the City's contract, the City's M/WBE policy, and signed participation reports: the prime contractor/consultant certifies all M/WBE payment information to be true and correct, to have all supporting documentation on file and to make copies of this documentation available to the City of Hinesville. **Prime contractors/consultants will periodically be required to provide copies of payment documentation** for M/WBEs being counted toward the M/WBE goal (including the prime contractor/consultant, if it is an M/WBE and being counted toward the goal). Failure to comply with the City's request to provide the required documentation may cause the City to withhold payments due the prime contractor/consultant until compliance is attained. Payment documentation includes but is not limited to:

- signed sub-contracts with M/WBEs being utilized in meeting the project's M/WBE goals
- M/WBE invoices for payment related to the project
- proof of payment of M/WBE invoices related to the project

<b>City M/WBE Office Use</b> Date Received: _____ Time Received: _____
--

## ADD/CHANGE OF M/WBE SUBCONTRACTOR FORM

**IMPORTANT NOTICE TO CONTRACTORS:** The prime contractor **may not** change M/WBE firms without **prior** written approval of the City's M/WBE Consultant. Changes **cannot** be approved by other City of Hinesville personnel. All requests for M/WBE substitutions must be made in writing, must include an explanation for the requested change, and must have supporting documentation. Additionally, all requested changes must continue to meet MBE and WBE goals, conform to contract regulations, utilize certified M/WBEs and meet M/WBE program requirements. **Any unauthorized substitution of M/WBE subcontractors may result in withholding of payment to the prime contractor for up to 30 days until compliance is reestablished.**

Project Name: \_\_\_\_\_ Project Number: \_\_\_\_\_

Prime Contractor/Consultant Name: \_\_\_\_\_

Address: \_\_\_\_\_ Telephone: \_\_\_\_\_

Prime Contractor/Consultant - Designee's Signature: \_\_\_\_\_ Date: \_\_\_\_\_

Position/Title: \_\_\_\_\_

APPROVED SCHEDULE OF M/WBE PARTICIPATION <i>(List certified M/WBEs that were approved per contract.)</i>			Proposed Change?	PROPOSED ADDITIONS OR CHANGES TO M/WBE PARTICIPATION <i>(Complete only for rows where "Proposed Change" is marked "Yes".)</i>			
M/WBE Subcontractor Name	MBE or WBE*	Estimated Subcontract Value		M/WBE Subcontractor Name	MBE or WBE*	Estimated Subcontract Value	Certified M/WBE? Y/N
			<input type="checkbox"/> Yes <input type="checkbox"/> No				
			<input type="checkbox"/> Yes <input type="checkbox"/> No				
			<input type="checkbox"/> Yes <input type="checkbox"/> No				
			<input type="checkbox"/> Yes <input type="checkbox"/> No				
			<input type="checkbox"/> Yes <input type="checkbox"/> No				
			<input type="checkbox"/> Yes <input type="checkbox"/> No				
			<input type="checkbox"/> Yes <input type="checkbox"/> No				
			<input type="checkbox"/> Yes <input type="checkbox"/> No				

\*A "WBE" is a business that is owned and controlled by a non-minority woman or women.

Provide a detailed explanation to justify any proposed changes noted in the table above. The explanation must provide a legitimate business-related reason for changing the approved M/WBE plan. (Attach additional sheets if needed.)

---



---



---



---

**City Engineer Consultant**

\_\_\_\_\_ Concerns noted regarding proposed change      \_\_\_\_\_ No concerns noted regarding proposed change

Project Manager Signature: \_\_\_\_\_ Date: \_\_\_\_\_

**M/WBE Consultant**

\_\_\_\_\_ Change Approved      \_\_\_\_\_ Change Denied

If denied, enter explanation: \_\_\_\_\_

Signature of M/WBE Office Representative \_\_\_\_\_ Date: \_\_\_\_\_

## PROPOSED SCHEDULE OF M/WBE PARTICIPATION

All M/WBEs listed **must be certified as a minority-owned or women-owned business** by the City of Hinesville or a federally-recognized or state-level certifying agency (such as USDOT, State DOT, or GMSDC) that utilizes certification standards comparable to the City of Hinesville **prior** to the due date of this bid. **Other business certifications that do not specify majority woman or minority ownership may not be substituted. Proof of M/WBE certification from the certifying agency is required to accompany the bid.** A firm that has submitted an application for M/WBE certification but has not been certified is not qualified as a certified M/WBE and will not be recognized as such during the City's evaluation process. To expedite verification, please provide accurate phone numbers for all M/WBEs listed and ensure firms understand contact will be made following bid submittal.

Name of Proposer: \_\_\_\_\_ Event No. \_\_\_\_\_

Project Title: \_\_\_\_\_

**NOTE: Unless certified through the City of Hinesville M/WBE Program, proof of M/WBE certification must be attached for all firms listed.**

Name of M/WBE Participant	Name of Majority Owner	Telephone	Address (City, State)	Type of Work Sub-Contracted	Estimated Sub-contract Value	MBE or WBE	Certified? (Y or N)	Certifying Agency? (City of H'ville or Other)
					%			
					%			
					%			
					%			
					%			
					%			

MBE Participation Value: \_\_\_\_\_ %      WBE Participation Value: \_\_\_\_\_ %      M/WBE Participation Value: \_\_\_\_\_ %

The undersigned will enter into a formal agreement with the M/WBE Subcontractors/Proposers identified herein for work listed in this schedule, conditioned upon executing a contract with the City of Hinesville. The Prime's subcontractor that subcontracts work must enter into a formal agreement with the tier subcontractor identified herein for work listed in this schedule. The Prime may count toward the goal any tier of M/WBE subcontractors and/or suppliers that will be utilized in the contract work. However, when an M/WBE subcontracts part of the work, the value of the subcontracted work may **only** be counted toward the goal **if the tier subcontractor is an M/WBE**. Any work an M/WBE firm subcontracts to a non-M/WBE firm **will not count toward the M/WBE goal**. It is the responsibility of the Prime contractor to advise all M/WBEs of this requirement and to ensure compliance by subcontractors.

### Joint Venture Disclosure

If the prime bidder is a joint venture, please describe the nature of the joint venture, the level of work and the financial participation to be provided by the Minority/Female joint venture firm in the space provided below.

Joint Venture Firms	Level of Work	Financial Participation

Printed name (company officer or representative): \_\_\_\_\_

Signature: \_\_\_\_\_

Date: \_\_\_\_\_

Title: \_\_\_\_\_

Email: \_\_\_\_\_

Telephone: \_\_\_\_\_

Fax: \_\_\_\_\_

*The Minority/Women Owned Business Consultant is available to assist with identifying certified M/WBEs. Please contact the M/WBE Consultant at (912) 368.3471.*

## NON-DISCRIMINATION STATEMENT

The prime contractor / bidder certifies that:

- (1) No person shall be excluded from participation in, denied the benefit of, or otherwise discriminated against on the basis of race, color, national origin, or gender in connection with any bid submitted to the City of Hinesville or the performance of any contract resulting thereof.
- (2) That it is and shall be the policy of this Company to provide equal opportunity to all business persons seeking to contract or otherwise interested in contracting with this Company, including those companies owned and controlled by racial minorities, cultural minorities, and women;
- (3) In connection herewith, we acknowledge and warrant that this Company has been made aware of, understands and agrees to take affirmative action to provide such companies with the maximum practicable opportunities to do business with this Company;
- (4) That this promise of non-discrimination as made and set forth herein shall be continuing in nature and shall remain in full force and effect without interruption;
- (5) That the promises of non-discrimination as made and set forth herein shall be and are hereby deemed to be made as part of and incorporated by reference into any contract or portion thereof which this Company may hereafter obtain and;
- (6) That the failure of this Company to satisfactorily discharge any of the promises of non-discrimination as made and set forth herein shall constitute a material breach of contract entitling the City of Hinesville to declare the contract in default and to exercise any and all applicable rights and remedies including but not limited to cancellation of the contract, termination of the contract, suspension and debarment from future contracting opportunities, and withholding and or forfeiture of compensation due and owing on a contract.

---

Signature

---

Title



This document has important legal consequences; consultation with an attorney is encouraged with respect to its use or modification. This document should be adapted to the particular circumstances of the contemplated Project and the controlling Laws and Regulations.

# STANDARD GENERAL CONDITIONS OF THE CONSTRUCTION CONTRACT

Prepared by

**ENGINEERS JOINT CONTRACT DOCUMENTS COMMITTEE**

and

Issued and Published Jointly by

**ACEC**

AMERICAN COUNCIL OF ENGINEERING COMPANIES



**ASCE** American Society  
of Civil Engineers



**National Society of  
Professional Engineers**  
Professional Engineers in Private Practice

AMERICAN COUNCIL OF ENGINEERING COMPANIES

ASSOCIATED GENERAL CONTRACTORS OF AMERICA

AMERICAN SOCIETY OF CIVIL ENGINEERS

PROFESSIONAL ENGINEERS IN PRIVATE PRACTICE

*A Practice Division of the*

NATIONAL SOCIETY OF PROFESSIONAL ENGINEERS

Endorsed by



CONSTRUCTION SPECIFICATIONS INSTITUTE

These General Conditions have been prepared for use with the Suggested Forms of Agreement Between Owner and Contractor (EJCDC C-520 or C-525, 2007 Editions). Their provisions are interrelated and a change in one may necessitate a change in the other. Comments concerning their usage are contained in the Narrative Guide to the EJCDC Construction Documents (EJCDC C-001, 2007 Edition). For guidance in the preparation of Supplementary Conditions, see Guide to the Preparation of Supplementary Conditions (EJCDC C-800, 2007 Edition).

Copyright © 2007 National Society of Professional Engineers  
1420 King Street, Alexandria, VA 22314-2794  
(703) 684-2882  
[www.nspe.org](http://www.nspe.org)

American Council of Engineering Companies  
1015 15th Street N.W., Washington, DC 20005  
(202) 347-7474  
[www.acec.org](http://www.acec.org)

American Society of Civil Engineers  
1801 Alexander Bell Drive, Reston, VA 20191-4400  
(800) 548-2723  
[www.asce.org](http://www.asce.org)

Associated General Contractors of America  
2300 Wilson Boulevard, Suite 400, Arlington, VA 22201-3308  
(703) 548-3118  
[www.agc.org](http://www.agc.org)

The copyright for this EJCDC document is owned jointly by the four EJCDC sponsoring organizations and held in trust for their benefit by NSPE.

**STANDARD GENERAL CONDITIONS OF THE  
CONSTRUCTION CONTRACT**

**TABLE OF CONTENTS**

	<b>Page</b>
Article 1 – Definitions and Terminology .....	1
1.01 Defined Terms.....	1
1.02 Terminology.....	5
Article 2 – Preliminary Matters .....	6
2.01 Delivery of Bonds and Evidence of Insurance .....	6
2.02 Copies of Documents.....	6
2.03 Commencement of Contract Times; Notice to Proceed.....	6
2.04 Starting the Work.....	7
2.05 Before Starting Construction .....	7
2.06 Preconstruction Conference; Designation of Authorized Representatives.....	7
2.07 Initial Acceptance of Schedules.....	7
Article 3 – Contract Documents: Intent, Amending, Reuse .....	8
3.01 Intent.....	8
3.02 Reference Standards.....	8
3.03 Reporting and Resolving Discrepancies.....	9
3.04 Amending and Supplementing Contract Documents.....	9
3.05 Reuse of Documents.....	10
3.06 Electronic Data.....	10
Article 4 – Availability of Lands; Subsurface and Physical Conditions; Hazardous Environmental Conditions; Reference Points.....	11
4.01 Availability of Lands.....	11
4.02 Subsurface and Physical Conditions.....	11
4.03 Differing Subsurface or Physical Conditions .....	12
4.04 Underground Facilities.....	13
4.05 Reference Points.....	14
4.06 Hazardous Environmental Condition at Site .....	14
Article 5 – Bonds and Insurance.....	16
5.01 Performance, Payment, and Other Bonds.....	16
5.02 Licensed Sureties and Insurers.....	16
5.03 Certificates of Insurance .....	17
5.04 Contractor’s Insurance .....	17
5.05 Owner’s Liability Insurance.....	19
5.06 Property Insurance.....	19
5.07 Waiver of Rights .....	20
5.08 Receipt and Application of Insurance Proceeds .....	21

5.09	Acceptance of Bonds and Insurance; Option to Replace .....	21
5.10	Partial Utilization, Acknowledgment of Property Insurer.....	22
Article 6 – Contractor’s Responsibilities .....		22
6.01	Supervision and Superintendence.....	22
6.02	Labor; Working Hours .....	22
6.03	Services, Materials, and Equipment .....	22
6.04	Progress Schedule .....	23
6.05	Substitutes and “Or-Equals” .....	23
6.06	Concerning Subcontractors, Suppliers, and Others.....	25
6.07	Patent Fees and Royalties .....	27
6.08	Permits.....	27
6.09	Laws and Regulations .....	28
6.10	Taxes .....	28
6.11	Use of Site and Other Areas.....	28
6.12	Record Documents.....	29
6.13	Safety and Protection .....	29
6.14	Safety Representative.....	30
6.15	Hazard Communication Programs.....	30
6.16	Emergencies .....	30
6.17	Shop Drawings and Samples .....	31
6.18	Continuing the Work.....	32
6.19	Contractor’s General Warranty and Guarantee .....	33
6.20	Indemnification .....	33
6.21	Delegation of Professional Design Services.....	34
Article 7 – Other Work at the Site.....		35
7.01	Related Work at Site .....	35
7.02	Coordination.....	35
7.03	Legal Relationships.....	36
Article 8 – Owner’s Responsibilities.....		36
8.01	Communications to Contractor.....	36
8.02	Replacement of Engineer .....	36
8.03	Furnish Data .....	36
8.04	Pay When Due.....	36
8.05	Lands and Easements; Reports and Tests.....	36
8.06	Insurance.....	36
8.07	Change Orders.....	37
8.08	Inspections, Tests, and Approvals .....	37
8.09	Limitations on Owner’s Responsibilities .....	37
8.10	Undisclosed Hazardous Environmental Condition .....	37
8.11	Evidence of Financial Arrangements.....	37
8.12	Compliance with Safety Program.....	37
Article 9 – Engineer’s Status During Construction.....		37
9.01	Owner’s Representative .....	37

9.02	Visits to Site .....	37
9.03	Project Representative.....	38
9.04	Authorized Variations in Work .....	38
9.05	Rejecting Defective Work.....	38
9.06	Shop Drawings, Change Orders and Payments.....	39
9.07	Determinations for Unit Price Work .....	39
9.08	Decisions on Requirements of Contract Documents and Acceptability of Work.....	39
9.09	Limitations on Engineer’s Authority and Responsibilities .....	39
9.10	Compliance with Safety Program.....	40
Article 10 – Changes in the Work; Claims .....		40
10.01	Authorized Changes in the Work .....	40
10.02	Unauthorized Changes in the Work.....	41
10.03	Execution of Change Orders.....	41
10.04	Notification to Surety.....	41
10.05	Claims.....	41
Article 11 – Cost of the Work; Allowances; Unit Price Work.....		42
11.01	Cost of the Work.....	42
11.02	Allowances .....	45
11.03	Unit Price Work .....	45
Article 12 – Change of Contract Price; Change of Contract Times .....		46
12.01	Change of Contract Price .....	46
12.02	Change of Contract Times .....	47
12.03	Delays.....	47
Article 13 – Tests and Inspections; Correction, Removal or Acceptance of Defective Work.....		48
13.01	Notice of Defects.....	48
13.02	Access to Work .....	48
13.03	Tests and Inspections .....	49
13.04	Uncovering Work.....	49
13.05	Owner May Stop the Work.....	50
13.06	Correction or Removal of Defective Work .....	50
13.07	Correction Period .....	50
13.08	Acceptance of Defective Work.....	51
13.09	Owner May Correct Defective Work .....	52
Article 14 – Payments to Contractor and Completion .....		52
14.01	Schedule of Values.....	52
14.02	Progress Payments .....	52
14.03	Contractor’s Warranty of Title.....	55
14.04	Substantial Completion.....	55
14.05	Partial Utilization .....	56
14.06	Final Inspection .....	57
14.07	Final Payment.....	57
14.08	Final Completion Delayed .....	58

14.09 Waiver of Claims .....	58
Article 15 – Suspension of Work and Termination .....	59
15.01 Owner May Suspend Work.....	59
15.02 Owner May Terminate for Cause .....	59
15.03 Owner May Terminate For Convenience .....	60
15.04 Contractor May Stop Work or Terminate.....	60
Article 16 – Dispute Resolution .....	61
16.01 Methods and Procedures .....	61
Article 17 – Miscellaneous .....	61
17.01 Giving Notice .....	61
17.02 Computation of Times .....	62
17.03 Cumulative Remedies .....	62
17.04 Survival of Obligations .....	62
17.05 Controlling Law .....	62
17.06 Headings.....	62

Not for Bid

## ARTICLE 1 – DEFINITIONS AND TERMINOLOGY

### 1.01 *Defined Terms*

- A. Wherever used in the Bidding Requirements or Contract Documents and printed with initial capital letters, the terms listed below will have the meanings indicated which are applicable to both the singular and plural thereof. In addition to terms specifically defined, terms with initial capital letters in the Contract Documents include references to identified articles and paragraphs, and the titles of other documents or forms.
1. *Addenda*—Written or graphic instruments issued prior to the opening of Bids which clarify, correct, or change the Bidding Requirements or the proposed Contract Documents.
  2. *Agreement*—The written instrument which is evidence of the agreement between Owner and Contractor covering the Work.
  3. *Application for Payment*—The form acceptable to Engineer which is to be used by Contractor during the course of the Work in requesting progress or final payments and which is to be accompanied by such supporting documentation as is required by the Contract Documents.
  4. *Asbestos*—Any material that contains more than one percent asbestos and is friable or is releasing asbestos fibers into the air above current action levels established by the United States Occupational Safety and Health Administration.
  5. *Bid*—The offer or proposal of a Bidder submitted on the prescribed form setting forth the prices for the Work to be performed.
  6. *Bidder*—The individual or entity who submits a Bid directly to Owner.
  7. *Bidding Documents*—The Bidding Requirements and the proposed Contract Documents (including all Addenda).
  8. *Bidding Requirements*—The advertisement or invitation to bid, Instructions to Bidders, Bid security of acceptable form, if any, and the Bid Form with any supplements.
  9. *Change Order*—A document recommended by Engineer which is signed by Contractor and Owner and authorizes an addition, deletion, or revision in the Work or an adjustment in the Contract Price or the Contract Times, issued on or after the Effective Date of the Agreement.
  10. *Claim*—A demand or assertion by Owner or Contractor seeking an adjustment of Contract Price or Contract Times, or both, or other relief with respect to the terms of the Contract. A demand for money or services by a third party is not a Claim.
  11. *Contract*—The entire and integrated written agreement between the Owner and Contractor concerning the Work. The Contract supersedes prior negotiations, representations, or agreements, whether written or oral.

12. *Contract Documents*—Those items so designated in the Agreement. Only printed or hard copies of the items listed in the Agreement are Contract Documents. Approved Shop Drawings, other Contractor submittals, and the reports and drawings of subsurface and physical conditions are not Contract Documents.
13. *Contract Price*—The moneys payable by Owner to Contractor for completion of the Work in accordance with the Contract Documents as stated in the Agreement (subject to the provisions of Paragraph 11.03 in the case of Unit Price Work).
14. *Contract Times*—The number of days or the dates stated in the Agreement to: (i) achieve Milestones, if any; (ii) achieve Substantial Completion; and (iii) complete the Work so that it is ready for final payment as evidenced by Engineer's written recommendation of final payment.
15. *Contractor*—The individual or entity with whom Owner has entered into the Agreement.
16. *Cost of the Work*—See Paragraph 11.01 for definition.
17. *Drawings*—That part of the Contract Documents prepared or approved by Engineer which graphically shows the scope, extent, and character of the Work to be performed by Contractor. Shop Drawings and other Contractor submittals are not Drawings as so defined.
18. *Effective Date of the Agreement*—The date indicated in the Agreement on which it becomes effective, but if no such date is indicated, it means the date on which the Agreement is signed and delivered by the last of the two parties to sign and deliver.
19. *Engineer*—The individual or entity named as such in the Agreement.
20. *Field Order*—A written order issued by Engineer which requires minor changes in the Work but which does not involve a change in the Contract Price or the Contract Times.
21. *General Requirements*—Sections of Division 1 of the Specifications.
22. *Hazardous Environmental Condition*—The presence at the Site of Asbestos, PCBs, Petroleum, Hazardous Waste, or Radioactive Material in such quantities or circumstances that may present a substantial danger to persons or property exposed thereto.
23. *Hazardous Waste*—The term Hazardous Waste shall have the meaning provided in Section 1004 of the Solid Waste Disposal Act (42 USC Section 6903) as amended from time to time.
24. *Laws and Regulations; Laws or Regulations*—Any and all applicable laws, rules, regulations, ordinances, codes, and orders of any and all governmental bodies, agencies, authorities, and courts having jurisdiction.
25. *Liens*—Charges, security interests, or encumbrances upon Project funds, real property, or personal property.
26. *Milestone*—A principal event specified in the Contract Documents relating to an intermediate completion date or time prior to Substantial Completion of all the Work.



27. *Notice of Award*—The written notice by Owner to the Successful Bidder stating that upon timely compliance by the Successful Bidder with the conditions precedent listed therein, Owner will sign and deliver the Agreement.
28. *Notice to Proceed*—A written notice given by Owner to Contractor fixing the date on which the Contract Times will commence to run and on which Contractor shall start to perform the Work under the Contract Documents.
29. *Owner*—The individual or entity with whom Contractor has entered into the Agreement and for whom the Work is to be performed.
30. *PCBs*—Polychlorinated biphenyls.
31. *Petroleum*—Petroleum, including crude oil or any fraction thereof which is liquid at standard conditions of temperature and pressure (60 degrees Fahrenheit and 14.7 pounds per square inch absolute), such as oil, petroleum, fuel oil, oil sludge, oil refuse, gasoline, kerosene, and oil mixed with other non-Hazardous Waste and crude oils.
32. *Progress Schedule*—A schedule, prepared and maintained by Contractor, describing the sequence and duration of the activities comprising the Contractor's plan to accomplish the Work within the Contract Times.
33. *Project*—The total construction of which the Work to be performed under the Contract Documents may be the whole, or a part.
34. *Project Manual*—The bound documentary information prepared for bidding and constructing the Work. A listing of the contents of the Project Manual, which may be bound in one or more volumes, is contained in the table(s) of contents.
35. *Radioactive Material*—Source, special nuclear, or byproduct material as defined by the Atomic Energy Act of 1954 (42 USC Section 2011 et seq.) as amended from time to time.
36. *Resident Project Representative*—The authorized representative of Engineer who may be assigned to the Site or any part thereof.
37. *Samples*—Physical examples of materials, equipment, or workmanship that are representative of some portion of the Work and which establish the standards by which such portion of the Work will be judged.
38. *Schedule of Submittals*—A schedule, prepared and maintained by Contractor, of required submittals and the time requirements to support scheduled performance of related construction activities.
39. *Schedule of Values*—A schedule, prepared and maintained by Contractor, allocating portions of the Contract Price to various portions of the Work and used as the basis for reviewing Contractor's Applications for Payment.

40. *Shop Drawings*—All drawings, diagrams, illustrations, schedules, and other data or information which are specifically prepared or assembled by or for Contractor and submitted by Contractor to illustrate some portion of the Work.
41. *Site*—Lands or areas indicated in the Contract Documents as being furnished by Owner upon which the Work is to be performed, including rights-of-way and easements for access thereto, and such other lands furnished by Owner which are designated for the use of Contractor.
42. *Specifications*—That part of the Contract Documents consisting of written requirements for materials, equipment, systems, standards and workmanship as applied to the Work, and certain administrative requirements and procedural matters applicable thereto.
43. *Subcontractor*—An individual or entity having a direct contract with Contractor or with any other Subcontractor for the performance of a part of the Work at the Site.
44. *Substantial Completion*—The time at which the Work (or a specified part thereof) has progressed to the point where, in the opinion of Engineer, the Work (or a specified part thereof) is sufficiently complete, in accordance with the Contract Documents, so that the Work (or a specified part thereof) can be utilized for the purposes for which it is intended. The terms “substantially complete” and “substantially completed” as applied to all or part of the Work refer to Substantial Completion thereof.
45. *Successful Bidder*—The Bidder submitting a responsive Bid to whom Owner makes an award.
46. *Supplementary Conditions*—That part of the Contract Documents which amends or supplements these General Conditions.
47. *Supplier*—A manufacturer, fabricator, supplier, distributor, materialman, or vendor having a direct contract with Contractor or with any Subcontractor to furnish materials or equipment to be incorporated in the Work by Contractor or Subcontractor.
48. *Underground Facilities*—All underground pipelines, conduits, ducts, cables, wires, manholes, vaults, tanks, tunnels, or other such facilities or attachments, and any encasements containing such facilities, including those that convey electricity, gases, steam, liquid petroleum products, telephone or other communications, cable television, water, wastewater, storm water, other liquids or chemicals, or traffic or other control systems.
49. *Unit Price Work*—Work to be paid for on the basis of unit prices.
50. *Work*—The entire construction or the various separately identifiable parts thereof required to be provided under the Contract Documents. Work includes and is the result of performing or providing all labor, services, and documentation necessary to produce such construction, and furnishing, installing, and incorporating all materials and equipment into such construction, all as required by the Contract Documents.
51. *Work Change Directive*—A written statement to Contractor issued on or after the Effective Date of the Agreement and signed by Owner and recommended by Engineer ordering an

addition, deletion, or revision in the Work, or responding to differing or unforeseen subsurface or physical conditions under which the Work is to be performed or to emergencies. A Work Change Directive will not change the Contract Price or the Contract Times but is evidence that the parties expect that the change ordered or documented by a Work Change Directive will be incorporated in a subsequently issued Change Order following negotiations by the parties as to its effect, if any, on the Contract Price or Contract Times.

## 1.02 Terminology

A. The words and terms discussed in Paragraph 1.02.B through F are not defined but, when used in the Bidding Requirements or Contract Documents, have the indicated meaning.

B. *Intent of Certain Terms or Adjectives:*

1. The Contract Documents include the terms “as allowed,” “as approved,” “as ordered,” “as directed” or terms of like effect or import to authorize an exercise of professional judgment by Engineer. In addition, the adjectives “reasonable,” “suitable,” “acceptable,” “proper,” “satisfactory,” or adjectives of like effect or import are used to describe an action or determination of Engineer as to the Work. It is intended that such exercise of professional judgment, action, or determination will be solely to evaluate, in general, the Work for compliance with the information in the Contract Documents and with the design concept of the Project as a functioning whole as shown or indicated in the Contract Documents (unless there is a specific statement indicating otherwise). The use of any such term or adjective is not intended to and shall not be effective to assign to Engineer any duty or authority to supervise or direct the performance of the Work, or any duty or authority to undertake responsibility contrary to the provisions of Paragraph 9.09 or any other provision of the Contract Documents.

C. *Day:*

1. The word “day” means a calendar day of 24 hours measured from midnight to the next midnight.

D. *Defective:*

1. The word “defective,” when modifying the word “Work,” refers to Work that is unsatisfactory, faulty, or deficient in that it:
  - a. does not conform to the Contract Documents; or
  - b. does not meet the requirements of any applicable inspection, reference standard, test, or approval referred to in the Contract Documents; or
  - c. has been damaged prior to Engineer’s recommendation of final payment (unless responsibility for the protection thereof has been assumed by Owner at Substantial Completion in accordance with Paragraph 14.04 or 14.05).

E. *Furnish, Install, Perform, Provide:*

1. The word “furnish,” when used in connection with services, materials, or equipment, shall mean to supply and deliver said services, materials, or equipment to the Site (or some other specified location) ready for use or installation and in usable or operable condition.
2. The word “install,” when used in connection with services, materials, or equipment, shall mean to put into use or place in final position said services, materials, or equipment complete and ready for intended use.
3. The words “perform” or “provide,” when used in connection with services, materials, or equipment, shall mean to furnish and install said services, materials, or equipment complete and ready for intended use.
4. When “furnish,” “install,” “perform,” or “provide” is not used in connection with services, materials, or equipment in a context clearly requiring an obligation of Contractor, “provide” is implied.

F. Unless stated otherwise in the Contract Documents, words or phrases that have a well-known technical or construction industry or trade meaning are used in the Contract Documents in accordance with such recognized meaning.

## ARTICLE 2 – PRELIMINARY MATTERS

### 2.01 *Delivery of Bonds and Evidence of Insurance*

- A. When Contractor delivers the executed counterparts of the Agreement to Owner, Contractor shall also deliver to Owner such bonds as Contractor may be required to furnish.
- B. *Evidence of Insurance:* Before any Work at the Site is started, Contractor and Owner shall each deliver to the other, with copies to each additional insured identified in the Supplementary Conditions, certificates of insurance (and other evidence of insurance which either of them or any additional insured may reasonably request) which Contractor and Owner respectively are required to purchase and maintain in accordance with Article 5.

### 2.02 *Copies of Documents*

- A. Owner shall furnish to Contractor up to ten printed or hard copies of the Drawings and Project Manual. Additional copies will be furnished upon request at the cost of reproduction.

### 2.03 *Commencement of Contract Times; Notice to Proceed*

- A. The Contract Times will commence to run on the thirtieth day after the Effective Date of the Agreement or, if a Notice to Proceed is given, on the day indicated in the Notice to Proceed. A Notice to Proceed may be given at any time within 30 days after the Effective Date of the Agreement. In no event will the Contract Times commence to run later than the sixtieth day after the day of Bid opening or the thirtieth day after the Effective Date of the Agreement, whichever date is earlier.

## 2.04 *Starting the Work*

- A. Contractor shall start to perform the Work on the date when the Contract Times commence to run. No Work shall be done at the Site prior to the date on which the Contract Times commence to run.

## 2.05 *Before Starting Construction*

- A. *Preliminary Schedules:* Within 10 days after the Effective Date of the Agreement (unless otherwise specified in the General Requirements), Contractor shall submit to Engineer for timely review:
  - 1. a preliminary Progress Schedule indicating the times (numbers of days or dates) for starting and completing the various stages of the Work, including any Milestones specified in the Contract Documents;
  - 2. a preliminary Schedule of Submittals; and
  - 3. a preliminary Schedule of Values for all of the Work which includes quantities and prices of items which when added together equal the Contract Price and subdivides the Work into component parts in sufficient detail to serve as the basis for progress payments during performance of the Work. Such prices will include an appropriate amount of overhead and profit applicable to each item of Work.

## 2.06 *Preconstruction Conference; Designation of Authorized Representatives*

- A. Before any Work at the Site is started, a conference attended by Owner, Contractor, Engineer, and others as appropriate will be held to establish a working understanding among the parties as to the Work and to discuss the schedules referred to in Paragraph 2.05.A, procedures for handling Shop Drawings and other submittals, processing Applications for Payment, and maintaining required records.
- B. At this conference Owner and Contractor each shall designate, in writing, a specific individual to act as its authorized representative with respect to the services and responsibilities under the Contract. Such individuals shall have the authority to transmit instructions, receive information, render decisions relative to the Contract, and otherwise act on behalf of each respective party.

## 2.07 *Initial Acceptance of Schedules*

- A. At least 10 days before submission of the first Application for Payment a conference attended by Contractor, Engineer, and others as appropriate will be held to review for acceptability to Engineer as provided below the schedules submitted in accordance with Paragraph 2.05.A. Contractor shall have an additional 10 days to make corrections and adjustments and to complete and resubmit the schedules. No progress payment shall be made to Contractor until acceptable schedules are submitted to Engineer.
  - 1. The Progress Schedule will be acceptable to Engineer if it provides an orderly progression of the Work to completion within the Contract Times. Such acceptance will not impose on

Engineer responsibility for the Progress Schedule, for sequencing, scheduling, or progress of the Work, nor interfere with or relieve Contractor from Contractor's full responsibility therefor.

2. Contractor's Schedule of Submittals will be acceptable to Engineer if it provides a workable arrangement for reviewing and processing the required submittals.
3. Contractor's Schedule of Values will be acceptable to Engineer as to form and substance if it provides a reasonable allocation of the Contract Price to component parts of the Work.

### **ARTICLE 3 – CONTRACT DOCUMENTS: INTENT, AMENDING, REUSE**

#### **3.01 *Intent***

- A. The Contract Documents are complementary; what is required by one is as binding as if required by all.
- B. It is the intent of the Contract Documents to describe a functionally complete project (or part thereof) to be constructed in accordance with the Contract Documents. Any labor, documentation, services, materials, or equipment that reasonably may be inferred from the Contract Documents or from prevailing custom or trade usage as being required to produce the indicated result will be provided whether or not specifically called for, at no additional cost to Owner.
- C. Clarifications and interpretations of the Contract Documents shall be issued by Engineer as provided in Article 9.

#### **3.02 *Reference Standards***

- A. Standards, Specifications, Codes, Laws, and Regulations
  1. Reference to standards, specifications, manuals, or codes of any technical society, organization, or association, or to Laws or Regulations, whether such reference be specific or by implication, shall mean the standard, specification, manual, code, or Laws or Regulations in effect at the time of opening of Bids (or on the Effective Date of the Agreement if there were no Bids), except as may be otherwise specifically stated in the Contract Documents.
  2. No provision of any such standard, specification, manual, or code, or any instruction of a Supplier, shall be effective to change the duties or responsibilities of Owner, Contractor, or Engineer, or any of their subcontractors, consultants, agents, or employees, from those set forth in the Contract Documents. No such provision or instruction shall be effective to assign to Owner, Engineer, or any of their officers, directors, members, partners, employees, agents, consultants, or subcontractors, any duty or authority to supervise or direct the performance of the Work or any duty or authority to undertake responsibility inconsistent with the provisions of the Contract Documents.

### 3.03 *Reporting and Resolving Discrepancies*

#### A. *Reporting Discrepancies:*

1. *Contractor's Review of Contract Documents Before Starting Work:* Before undertaking each part of the Work, Contractor shall carefully study and compare the Contract Documents and check and verify pertinent figures therein and all applicable field measurements. Contractor shall promptly report in writing to Engineer any conflict, error, ambiguity, or discrepancy which Contractor discovers, or has actual knowledge of, and shall obtain a written interpretation or clarification from Engineer before proceeding with any Work affected thereby.
2. *Contractor's Review of Contract Documents During Performance of Work:* If, during the performance of the Work, Contractor discovers any conflict, error, ambiguity, or discrepancy within the Contract Documents, or between the Contract Documents and (a) any applicable Law or Regulation, (b) any standard, specification, manual, or code, or (c) any instruction of any Supplier, then Contractor shall promptly report it to Engineer in writing. Contractor shall not proceed with the Work affected thereby (except in an emergency as required by Paragraph 6.16.A) until an amendment or supplement to the Contract Documents has been issued by one of the methods indicated in Paragraph 3.04.
3. Contractor shall not be liable to Owner or Engineer for failure to report any conflict, error, ambiguity, or discrepancy in the Contract Documents unless Contractor had actual knowledge thereof.

#### B. *Resolving Discrepancies:*

1. Except as may be otherwise specifically stated in the Contract Documents, the provisions of the Contract Documents shall take precedence in resolving any conflict, error, ambiguity, or discrepancy between the provisions of the Contract Documents and:
  - a. the provisions of any standard, specification, manual, or code, or the instruction of any Supplier (whether or not specifically incorporated by reference in the Contract Documents); or
  - b. the provisions of any Laws or Regulations applicable to the performance of the Work (unless such an interpretation of the provisions of the Contract Documents would result in violation of such Law or Regulation).

### 3.04 *Amending and Supplementing Contract Documents*

- A. The Contract Documents may be amended to provide for additions, deletions, and revisions in the Work or to modify the terms and conditions thereof by either a Change Order or a Work Change Directive.
- B. The requirements of the Contract Documents may be supplemented, and minor variations and deviations in the Work may be authorized, by one or more of the following ways:

1. A Field Order;
2. Engineer's approval of a Shop Drawing or Sample (subject to the provisions of Paragraph 6.17.D.3); or
3. Engineer's written interpretation or clarification.

3.05 *Reuse of Documents*

A. Contractor and any Subcontractor or Supplier shall not:

1. have or acquire any title to or ownership rights in any of the Drawings, Specifications, or other documents (or copies of any thereof) prepared by or bearing the seal of Engineer or its consultants, including electronic media editions; or
2. reuse any such Drawings, Specifications, other documents, or copies thereof on extensions of the Project or any other project without written consent of Owner and Engineer and specific written verification or adaptation by Engineer.

B. The prohibitions of this Paragraph 3.05 will survive final payment, or termination of the Contract. Nothing herein shall preclude Contractor from retaining copies of the Contract Documents for record purposes.

3.06 *Electronic Data*

- A. Unless otherwise stated in the Supplementary Conditions, the data furnished by Owner or Engineer to Contractor, or by Contractor to Owner or Engineer, that may be relied upon are limited to the printed copies (also known as hard copies). Files in electronic media format of text, data, graphics, or other types are furnished only for the convenience of the receiving party. Any conclusion or information obtained or derived from such electronic files will be at the user's sole risk. If there is a discrepancy between the electronic files and the hard copies, the hard copies govern.
- B. Because data stored in electronic media format can deteriorate or be modified inadvertently or otherwise without authorization of the data's creator, the party receiving electronic files agrees that it will perform acceptance tests or procedures within 60 days, after which the receiving party shall be deemed to have accepted the data thus transferred. Any errors detected within the 60-day acceptance period will be corrected by the transferring party.
- C. When transferring documents in electronic media format, the transferring party makes no representations as to long term compatibility, usability, or readability of documents resulting from the use of software application packages, operating systems, or computer hardware differing from those used by the data's creator.



**ARTICLE 4 – AVAILABILITY OF LANDS; SUBSURFACE AND PHYSICAL CONDITIONS;  
HAZARDOUS ENVIRONMENTAL CONDITIONS; REFERENCE POINTS**

4.01 *Availability of Lands*

- A. Owner shall furnish the Site. Owner shall notify Contractor of any encumbrances or restrictions not of general application but specifically related to use of the Site with which Contractor must comply in performing the Work. Owner will obtain in a timely manner and pay for easements for permanent structures or permanent changes in existing facilities. If Contractor and Owner are unable to agree on entitlement to or on the amount or extent, if any, of any adjustment in the Contract Price or Contract Times, or both, as a result of any delay in Owner's furnishing the Site or a part thereof, Contractor may make a Claim therefor as provided in Paragraph 10.05.
- B. Upon reasonable written request, Owner shall furnish Contractor with a current statement of record legal title and legal description of the lands upon which the Work is to be performed and Owner's interest therein as necessary for giving notice of or filing a mechanic's or construction lien against such lands in accordance with applicable Laws and Regulations.
- C. Contractor shall provide for all additional lands and access thereto that may be required for temporary construction facilities or storage of materials and equipment.

4.02 *Subsurface and Physical Conditions*

- A. *Reports and Drawings:* The Supplementary Conditions identify:
  - 1. those reports known to Owner of explorations and tests of subsurface conditions at or contiguous to the Site; and
  - 2. those drawings known to Owner of physical conditions relating to existing surface or subsurface structures at the Site (except Underground Facilities).
- B. *Limited Reliance by Contractor on Technical Data Authorized:* Contractor may rely upon the accuracy of the "technical data" contained in such reports and drawings, but such reports and drawings are not Contract Documents. Such "technical data" is identified in the Supplementary Conditions. Except for such reliance on such "technical data," Contractor may not rely upon or make any claim against Owner or Engineer, or any of their officers, directors, members, partners, employees, agents, consultants, or subcontractors with respect to:
  - 1. the completeness of such reports and drawings for Contractor's purposes, including, but not limited to, any aspects of the means, methods, techniques, sequences, and procedures of construction to be employed by Contractor, and safety precautions and programs incident thereto; or
  - 2. other data, interpretations, opinions, and information contained in such reports or shown or indicated in such drawings; or
  - 3. any Contractor interpretation of or conclusion drawn from any "technical data" or any such other data, interpretations, opinions, or information.

#### 4.03 *Differing Subsurface or Physical Conditions*

- A. *Notice:* If Contractor believes that any subsurface or physical condition that is uncovered or revealed either:
1. is of such a nature as to establish that any “technical data” on which Contractor is entitled to rely as provided in Paragraph 4.02 is materially inaccurate; or
  2. is of such a nature as to require a change in the Contract Documents; or
  3. differs materially from that shown or indicated in the Contract Documents; or
  4. is of an unusual nature, and differs materially from conditions ordinarily encountered and generally recognized as inherent in work of the character provided for in the Contract Documents;

then Contractor shall, promptly after becoming aware thereof and before further disturbing the subsurface or physical conditions or performing any Work in connection therewith (except in an emergency as required by Paragraph 6.16.A), notify Owner and Engineer in writing about such condition. Contractor shall not further disturb such condition or perform any Work in connection therewith (except as aforesaid) until receipt of written order to do so.

- B. *Engineer’s Review:* After receipt of written notice as required by Paragraph 4.03.A, Engineer will promptly review the pertinent condition, determine the necessity of Owner’s obtaining additional exploration or tests with respect thereto, and advise Owner in writing (with a copy to Contractor) of Engineer’s findings and conclusions.

C. *Possible Price and Times Adjustments:*

1. The Contract Price or the Contract Times, or both, will be equitably adjusted to the extent that the existence of such differing subsurface or physical condition causes an increase or decrease in Contractor’s cost of, or time required for, performance of the Work; subject, however, to the following:
  - a. such condition must meet any one or more of the categories described in Paragraph 4.03.A; and
  - b. with respect to Work that is paid for on a unit price basis, any adjustment in Contract Price will be subject to the provisions of Paragraphs 9.07 and 11.03.
2. Contractor shall not be entitled to any adjustment in the Contract Price or Contract Times if:
  - a. Contractor knew of the existence of such conditions at the time Contractor made a final commitment to Owner with respect to Contract Price and Contract Times by the submission of a Bid or becoming bound under a negotiated contract; or
  - b. the existence of such condition could reasonably have been discovered or revealed as a result of any examination, investigation, exploration, test, or study of the Site and

contiguous areas required by the Bidding Requirements or Contract Documents to be conducted by or for Contractor prior to Contractor's making such final commitment; or

- c. Contractor failed to give the written notice as required by Paragraph 4.03.A.
3. If Owner and Contractor are unable to agree on entitlement to or on the amount or extent, if any, of any adjustment in the Contract Price or Contract Times, or both, a Claim may be made therefor as provided in Paragraph 10.05. However, neither Owner or Engineer, or any of their officers, directors, members, partners, employees, agents, consultants, or subcontractors shall be liable to Contractor for any claims, costs, losses, or damages (including but not limited to all fees and charges of engineers, architects, attorneys, and other professionals and all court or arbitration or other dispute resolution costs) sustained by Contractor on or in connection with any other project or anticipated project.

#### 4.04 *Underground Facilities*

A. *Shown or Indicated:* The information and data shown or indicated in the Contract Documents with respect to existing Underground Facilities at or contiguous to the Site is based on information and data furnished to Owner or Engineer by the owners of such Underground Facilities, including Owner, or by others. Unless it is otherwise expressly provided in the Supplementary Conditions:

1. Owner and Engineer shall not be responsible for the accuracy or completeness of any such information or data provided by others; and
2. the cost of all of the following will be included in the Contract Price, and Contractor shall have full responsibility for:
  - a. reviewing and checking all such information and data;
  - b. locating all Underground Facilities shown or indicated in the Contract Documents;
  - c. coordination of the Work with the owners of such Underground Facilities, including Owner, during construction; and
  - d. the safety and protection of all such Underground Facilities and repairing any damage thereto resulting from the Work.

B. *Not Shown or Indicated:*

1. If an Underground Facility is uncovered or revealed at or contiguous to the Site which was not shown or indicated, or not shown or indicated with reasonable accuracy in the Contract Documents, Contractor shall, promptly after becoming aware thereof and before further disturbing conditions affected thereby or performing any Work in connection therewith (except in an emergency as required by Paragraph 6.16.A), identify the owner of such Underground Facility and give written notice to that owner and to Owner and Engineer. Engineer will promptly review the Underground Facility and determine the extent, if any, to which a change is required in the Contract Documents to reflect and document the

consequences of the existence or location of the Underground Facility. During such time, Contractor shall be responsible for the safety and protection of such Underground Facility.

2. If Engineer concludes that a change in the Contract Documents is required, a Work Change Directive or a Change Order will be issued to reflect and document such consequences. An equitable adjustment shall be made in the Contract Price or Contract Times, or both, to the extent that they are attributable to the existence or location of any Underground Facility that was not shown or indicated or not shown or indicated with reasonable accuracy in the Contract Documents and that Contractor did not know of and could not reasonably have been expected to be aware of or to have anticipated. If Owner and Contractor are unable to agree on entitlement to or on the amount or extent, if any, of any such adjustment in Contract Price or Contract Times, Owner or Contractor may make a Claim therefor as provided in Paragraph 10.05.

#### 4.05 *Reference Points*

- A. Owner shall provide engineering surveys to establish reference points for construction which in Engineer's judgment are necessary to enable Contractor to proceed with the Work. Contractor shall be responsible for laying out the Work, shall protect and preserve the established reference points and property monuments, and shall make no changes or relocations without the prior written approval of Owner. Contractor shall report to Engineer whenever any reference point or property monument is lost or destroyed or requires relocation because of necessary changes in grades or locations, and shall be responsible for the accurate replacement or relocation of such reference points or property monuments by professionally qualified personnel.

#### 4.06 *Hazardous Environmental Condition at Site*

- A. *Reports and Drawings:* The Supplementary Conditions identify those reports and drawings known to Owner relating to Hazardous Environmental Conditions that have been identified at the Site.
- B. *Limited Reliance by Contractor on Technical Data Authorized:* Contractor may rely upon the accuracy of the "technical data" contained in such reports and drawings, but such reports and drawings are not Contract Documents. Such "technical data" is identified in the Supplementary Conditions. Except for such reliance on such "technical data," Contractor may not rely upon or make any claim against Owner or Engineer, or any of their officers, directors, members, partners, employees, agents, consultants, or subcontractors with respect to:
  1. the completeness of such reports and drawings for Contractor's purposes, including, but not limited to, any aspects of the means, methods, techniques, sequences and procedures of construction to be employed by Contractor and safety precautions and programs incident thereto; or
  2. other data, interpretations, opinions and information contained in such reports or shown or indicated in such drawings; or
  3. any Contractor interpretation of or conclusion drawn from any "technical data" or any such other data, interpretations, opinions or information.

- C. Contractor shall not be responsible for any Hazardous Environmental Condition uncovered or revealed at the Site which was not shown or indicated in Drawings or Specifications or identified in the Contract Documents to be within the scope of the Work. Contractor shall be responsible for a Hazardous Environmental Condition created with any materials brought to the Site by Contractor, Subcontractors, Suppliers, or anyone else for whom Contractor is responsible.
- D. If Contractor encounters a Hazardous Environmental Condition or if Contractor or anyone for whom Contractor is responsible creates a Hazardous Environmental Condition, Contractor shall immediately: (i) secure or otherwise isolate such condition; (ii) stop all Work in connection with such condition and in any area affected thereby (except in an emergency as required by Paragraph 6.16.A); and (iii) notify Owner and Engineer (and promptly thereafter confirm such notice in writing). Owner shall promptly consult with Engineer concerning the necessity for Owner to retain a qualified expert to evaluate such condition or take corrective action, if any. Promptly after consulting with Engineer, Owner shall take such actions as are necessary to permit Owner to timely obtain required permits and provide Contractor the written notice required by Paragraph 4.06.E.
- E. Contractor shall not be required to resume Work in connection with such condition or in any affected area until after Owner has obtained any required permits related thereto and delivered written notice to Contractor: (i) specifying that such condition and any affected area is or has been rendered safe for the resumption of Work; or (ii) specifying any special conditions under which such Work may be resumed safely. If Owner and Contractor cannot agree as to entitlement to or on the amount or extent, if any, of any adjustment in Contract Price or Contract Times, or both, as a result of such Work stoppage or such special conditions under which Work is agreed to be resumed by Contractor, either party may make a Claim therefor as provided in Paragraph 10.05.
- F. If after receipt of such written notice Contractor does not agree to resume such Work based on a reasonable belief it is unsafe, or does not agree to resume such Work under such special conditions, then Owner may order the portion of the Work that is in the area affected by such condition to be deleted from the Work. If Owner and Contractor cannot agree as to entitlement to or on the amount or extent, if any, of an adjustment in Contract Price or Contract Times as a result of deleting such portion of the Work, then either party may make a Claim therefor as provided in Paragraph 10.05. Owner may have such deleted portion of the Work performed by Owner's own forces or others in accordance with Article 7.
- G. To the fullest extent permitted by Laws and Regulations, Owner shall indemnify and hold harmless Contractor, Subcontractors, and Engineer, and the officers, directors, members, partners, employees, agents, consultants, and subcontractors of each and any of them from and against all claims, costs, losses, and damages (including but not limited to all fees and charges of engineers, architects, attorneys, and other professionals and all court or arbitration or other dispute resolution costs) arising out of or relating to a Hazardous Environmental Condition, provided that such Hazardous Environmental Condition: (i) was not shown or indicated in the Drawings or Specifications or identified in the Contract Documents to be included within the scope of the Work, and (ii) was not created by Contractor or by anyone for whom Contractor is responsible. Nothing in this Paragraph 4.06.G shall obligate Owner to indemnify any individual or entity from and against the consequences of that individual's or entity's own negligence.

- H. To the fullest extent permitted by Laws and Regulations, Contractor shall indemnify and hold harmless Owner and Engineer, and the officers, directors, members, partners, employees, agents, consultants, and subcontractors of each and any of them from and against all claims, costs, losses, and damages (including but not limited to all fees and charges of engineers, architects, attorneys, and other professionals and all court or arbitration or other dispute resolution costs) arising out of or relating to a Hazardous Environmental Condition created by Contractor or by anyone for whom Contractor is responsible. Nothing in this Paragraph 4.06.H shall obligate Contractor to indemnify any individual or entity from and against the consequences of that individual's or entity's own negligence.
- I. The provisions of Paragraphs 4.02, 4.03, and 4.04 do not apply to a Hazardous Environmental Condition uncovered or revealed at the Site.

## **ARTICLE 5 – BONDS AND INSURANCE**

### *5.01 Performance, Payment, and Other Bonds*

- A. Contractor shall furnish performance and payment bonds, each in an amount at least equal to the Contract Price as security for the faithful performance and payment of all of Contractor's obligations under the Contract Documents. These bonds shall remain in effect until one year after the date when final payment becomes due or until completion of the correction period specified in Paragraph 13.07, whichever is later, except as provided otherwise by Laws or Regulations or by the Contract Documents. Contractor shall also furnish such other bonds as are required by the Contract Documents.
- B. All bonds shall be in the form prescribed by the Contract Documents except as provided otherwise by Laws or Regulations, and shall be executed by such sureties as are named in the list of "Companies Holding Certificates of Authority as Acceptable Sureties on Federal Bonds and as Acceptable Reinsuring Companies" as published in Circular 570 (amended) by the Financial Management Service, Surety Bond Branch, U.S. Department of the Treasury. All bonds signed by an agent or attorney-in-fact must be accompanied by a certified copy of that individual's authority to bind the surety. The evidence of authority shall show that it is effective on the date the agent or attorney-in-fact signed each bond.
- C. If the surety on any bond furnished by Contractor is declared bankrupt or becomes insolvent or its right to do business is terminated in any state where any part of the Project is located or it ceases to meet the requirements of Paragraph 5.01.B, Contractor shall promptly notify Owner and Engineer and shall, within 20 days after the event giving rise to such notification, provide another bond and surety, both of which shall comply with the requirements of Paragraphs 5.01.B and 5.02.

### *5.02 Licensed Sureties and Insurers*

- A. All bonds and insurance required by the Contract Documents to be purchased and maintained by Owner or Contractor shall be obtained from surety or insurance companies that are duly licensed or authorized in the jurisdiction in which the Project is located to issue bonds or insurance policies for the limits and coverages so required. Such surety and insurance companies shall also

meet such additional requirements and qualifications as may be provided in the Supplementary Conditions.

#### 5.03 *Certificates of Insurance*

- A. Contractor shall deliver to Owner, with copies to each additional insured and loss payee identified in the Supplementary Conditions, certificates of insurance (and other evidence of insurance requested by Owner or any other additional insured) which Contractor is required to purchase and maintain.
- B. Owner shall deliver to Contractor, with copies to each additional insured and loss payee identified in the Supplementary Conditions, certificates of insurance (and other evidence of insurance requested by Contractor or any other additional insured) which Owner is required to purchase and maintain.
- C. Failure of Owner to demand such certificates or other evidence of Contractor's full compliance with these insurance requirements or failure of Owner to identify a deficiency in compliance from the evidence provided shall not be construed as a waiver of Contractor's obligation to maintain such insurance.
- D. Owner does not represent that insurance coverage and limits established in this Contract necessarily will be adequate to protect Contractor.
- E. The insurance and insurance limits required herein shall not be deemed as a limitation on Contractor's liability under the indemnities granted to Owner in the Contract Documents.

#### 5.04 *Contractor's Insurance*

- A. Contractor shall purchase and maintain such insurance as is appropriate for the Work being performed and as will provide protection from claims set forth below which may arise out of or result from Contractor's performance of the Work and Contractor's other obligations under the Contract Documents, whether it is to be performed by Contractor, any Subcontractor or Supplier, or by anyone directly or indirectly employed by any of them to perform any of the Work, or by anyone for whose acts any of them may be liable:
  - 1. claims under workers' compensation, disability benefits, and other similar employee benefit acts;
  - 2. claims for damages because of bodily injury, occupational sickness or disease, or death of Contractor's employees;
  - 3. claims for damages because of bodily injury, sickness or disease, or death of any person other than Contractor's employees;
  - 4. claims for damages insured by reasonably available personal injury liability coverage which are sustained:

- a. by any person as a result of an offense directly or indirectly related to the employment of such person by Contractor, or
  - b. by any other person for any other reason;
5. claims for damages, other than to the Work itself, because of injury to or destruction of tangible property wherever located, including loss of use resulting therefrom; and
  6. claims for damages because of bodily injury or death of any person or property damage arising out of the ownership, maintenance or use of any motor vehicle.
- B. The policies of insurance required by this Paragraph 5.04 shall:
1. with respect to insurance required by Paragraphs 5.04.A.3 through 5.04.A.6 inclusive, be written on an occurrence basis, include as additional insureds (subject to any customary exclusion regarding professional liability) Owner and Engineer, and any other individuals or entities identified in the Supplementary Conditions, all of whom shall be listed as additional insureds, and include coverage for the respective officers, directors, members, partners, employees, agents, consultants, and subcontractors of each and any of all such additional insureds, and the insurance afforded to these additional insureds shall provide primary coverage for all claims covered thereby;
  2. include at least the specific coverages and be written for not less than the limits of liability provided in the Supplementary Conditions or required by Laws or Regulations, whichever is greater;
  3. include contractual liability insurance covering Contractor's indemnity obligations under Paragraphs 6.11 and 6.20;
  4. contain a provision or endorsement that the coverage afforded will not be canceled, materially changed or renewal refused until at least 30 days prior written notice has been given to Owner and Contractor and to each other additional insured identified in the Supplementary Conditions to whom a certificate of insurance has been issued (and the certificates of insurance furnished by the Contractor pursuant to Paragraph 5.03 will so provide);
  5. remain in effect at least until final payment and at all times thereafter when Contractor may be correcting, removing, or replacing defective Work in accordance with Paragraph 13.07; and
  6. include completed operations coverage:
    - a. Such insurance shall remain in effect for two years after final payment.
    - b. Contractor shall furnish Owner and each other additional insured identified in the Supplementary Conditions, to whom a certificate of insurance has been issued, evidence satisfactory to Owner and any such additional insured of continuation of such insurance at final payment and one year thereafter.



5.05 *Owner's Liability Insurance*

- A. In addition to the insurance required to be provided by Contractor under Paragraph 5.04, Owner, at Owner's option, may purchase and maintain at Owner's expense Owner's own liability insurance as will protect Owner against claims which may arise from operations under the Contract Documents.

5.06 *Property Insurance*

- A. Unless otherwise provided in the Supplementary Conditions, Owner shall purchase and maintain property insurance upon the Work at the Site in the amount of the full replacement cost thereof (subject to such deductible amounts as may be provided in the Supplementary Conditions or required by Laws and Regulations). This insurance shall:
1. include the interests of Owner, Contractor, Subcontractors, and Engineer, and any other individuals or entities identified in the Supplementary Conditions, and the officers, directors, members, partners, employees, agents, consultants, and subcontractors of each and any of them, each of whom is deemed to have an insurable interest and shall be listed as a loss payee;
  2. be written on a Builder's Risk "all-risk" policy form that shall at least include insurance for physical loss or damage to the Work, temporary buildings, falsework, and materials and equipment in transit, and shall insure against at least the following perils or causes of loss: fire, lightning, extended coverage, theft, vandalism and malicious mischief, earthquake, collapse, debris removal, demolition occasioned by enforcement of Laws and Regulations, water damage (other than that caused by flood), and such other perils or causes of loss as may be specifically required by the Supplementary Conditions.
  3. include expenses incurred in the repair or replacement of any insured property (including but not limited to fees and charges of engineers and architects);
  4. cover materials and equipment stored at the Site or at another location that was agreed to in writing by Owner prior to being incorporated in the Work, provided that such materials and equipment have been included in an Application for Payment recommended by Engineer;
  5. allow for partial utilization of the Work by Owner;
  6. include testing and startup; and
  7. be maintained in effect until final payment is made unless otherwise agreed to in writing by Owner, Contractor, and Engineer with 30 days written notice to each other loss payee to whom a certificate of insurance has been issued.
- B. Owner shall purchase and maintain such equipment breakdown insurance or additional property insurance as may be required by the Supplementary Conditions or Laws and Regulations which will include the interests of Owner, Contractor, Subcontractors, and Engineer, and any other individuals or entities identified in the Supplementary Conditions, and the officers, directors,

members, partners, employees, agents, consultants and subcontractors of each and any of them, each of whom is deemed to have an insurable interest and shall be listed as a loss payee.

- C. All the policies of insurance (and the certificates or other evidence thereof) required to be purchased and maintained in accordance with this Paragraph 5.06 will contain a provision or endorsement that the coverage afforded will not be canceled or materially changed or renewal refused until at least 30 days prior written notice has been given to Owner and Contractor and to each other loss payee to whom a certificate of insurance has been issued and will contain waiver provisions in accordance with Paragraph 5.07.
- D. Owner shall not be responsible for purchasing and maintaining any property insurance specified in this Paragraph 5.06 to protect the interests of Contractor, Subcontractors, or others in the Work to the extent of any deductible amounts that are identified in the Supplementary Conditions. The risk of loss within such identified deductible amount will be borne by Contractor, Subcontractors, or others suffering any such loss, and if any of them wishes property insurance coverage within the limits of such amounts, each may purchase and maintain it at the purchaser's own expense.
- E. If Contractor requests in writing that other special insurance be included in the property insurance policies provided under this Paragraph 5.06, Owner shall, if possible, include such insurance, and the cost thereof will be charged to Contractor by appropriate Change Order. Prior to commencement of the Work at the Site, Owner shall in writing advise Contractor whether or not such other insurance has been procured by Owner.

#### 5.07 *Waiver of Rights*

- A. Owner and Contractor intend that all policies purchased in accordance with Paragraph 5.06 will protect Owner, Contractor, Subcontractors, and Engineer, and all other individuals or entities identified in the Supplementary Conditions as loss payees (and the officers, directors, members, partners, employees, agents, consultants, and subcontractors of each and any of them) in such policies and will provide primary coverage for all losses and damages caused by the perils or causes of loss covered thereby. All such policies shall contain provisions to the effect that in the event of payment of any loss or damage the insurers will have no rights of recovery against any of the insureds or loss payees thereunder. Owner and Contractor waive all rights against each other and their respective officers, directors, members, partners, employees, agents, consultants and subcontractors of each and any of them for all losses and damages caused by, arising out of or resulting from any of the perils or causes of loss covered by such policies and any other property insurance applicable to the Work; and, in addition, waive all such rights against Subcontractors and Engineer, and all other individuals or entities identified in the Supplementary Conditions as loss payees (and the officers, directors, members, partners, employees, agents, consultants, and subcontractors of each and any of them) under such policies for losses and damages so caused. None of the above waivers shall extend to the rights that any party making such waiver may have to the proceeds of insurance held by Owner as trustee or otherwise payable under any policy so issued.
- B. Owner waives all rights against Contractor, Subcontractors, and Engineer, and the officers, directors, members, partners, employees, agents, consultants and subcontractors of each and any of them for:

1. loss due to business interruption, loss of use, or other consequential loss extending beyond direct physical loss or damage to Owner's property or the Work caused by, arising out of, or resulting from fire or other perils whether or not insured by Owner; and
  2. loss or damage to the completed Project or part thereof caused by, arising out of, or resulting from fire or other insured peril or cause of loss covered by any property insurance maintained on the completed Project or part thereof by Owner during partial utilization pursuant to Paragraph 14.05, after Substantial Completion pursuant to Paragraph 14.04, or after final payment pursuant to Paragraph 14.07.
- C. Any insurance policy maintained by Owner covering any loss, damage or consequential loss referred to in Paragraph 5.07.B shall contain provisions to the effect that in the event of payment of any such loss, damage, or consequential loss, the insurers will have no rights of recovery against Contractor, Subcontractors, or Engineer, and the officers, directors, members, partners, employees, agents, consultants and subcontractors of each and any of them.

#### 5.08 *Receipt and Application of Insurance Proceeds*

- A. Any insured loss under the policies of insurance required by Paragraph 5.06 will be adjusted with Owner and made payable to Owner as fiduciary for the loss payees, as their interests may appear, subject to the requirements of any applicable mortgage clause and of Paragraph 5.08.B. Owner shall deposit in a separate account any money so received and shall distribute it in accordance with such agreement as the parties in interest may reach. If no other special agreement is reached, the damaged Work shall be repaired or replaced, the moneys so received applied on account thereof, and the Work and the cost thereof covered by an appropriate Change Order.
- B. Owner as fiduciary shall have power to adjust and settle any loss with the insurers unless one of the parties in interest shall object in writing within 15 days after the occurrence of loss to Owner's exercise of this power. If such objection be made, Owner as fiduciary shall make settlement with the insurers in accordance with such agreement as the parties in interest may reach. If no such agreement among the parties in interest is reached, Owner as fiduciary shall adjust and settle the loss with the insurers and, if required in writing by any party in interest, Owner as fiduciary shall give bond for the proper performance of such duties.

#### 5.09 *Acceptance of Bonds and Insurance; Option to Replace*

- A. If either Owner or Contractor has any objection to the coverage afforded by or other provisions of the bonds or insurance required to be purchased and maintained by the other party in accordance with Article 5 on the basis of non-conformance with the Contract Documents, the objecting party shall so notify the other party in writing within 10 days after receipt of the certificates (or other evidence requested) required by Paragraph 2.01.B. Owner and Contractor shall each provide to the other such additional information in respect of insurance provided as the other may reasonably request. If either party does not purchase or maintain all of the bonds and insurance required of such party by the Contract Documents, such party shall notify the other party in writing of such failure to purchase prior to the start of the Work, or of such failure to maintain prior to any change in the required coverage. Without prejudice to any other right or remedy, the other party may elect to obtain equivalent bonds or insurance to protect such other party's

interests at the expense of the party who was required to provide such coverage, and a Change Order shall be issued to adjust the Contract Price accordingly.

#### 5.10 *Partial Utilization, Acknowledgment of Property Insurer*

- A. If Owner finds it necessary to occupy or use a portion or portions of the Work prior to Substantial Completion of all the Work as provided in Paragraph 14.05, no such use or occupancy shall commence before the insurers providing the property insurance pursuant to Paragraph 5.06 have acknowledged notice thereof and in writing effected any changes in coverage necessitated thereby. The insurers providing the property insurance shall consent by endorsement on the policy or policies, but the property insurance shall not be canceled or permitted to lapse on account of any such partial use or occupancy.

### **ARTICLE 6 – CONTRACTOR’S RESPONSIBILITIES**

#### 6.01 *Supervision and Superintendence*

- A. Contractor shall supervise, inspect, and direct the Work competently and efficiently, devoting such attention thereto and applying such skills and expertise as may be necessary to perform the Work in accordance with the Contract Documents. Contractor shall be solely responsible for the means, methods, techniques, sequences, and procedures of construction. Contractor shall not be responsible for the negligence of Owner or Engineer in the design or specification of a specific means, method, technique, sequence, or procedure of construction which is shown or indicated in and expressly required by the Contract Documents.
- B. At all times during the progress of the Work, Contractor shall assign a competent resident superintendent who shall not be replaced without written notice to Owner and Engineer except under extraordinary circumstances.

#### 6.02 *Labor; Working Hours*

- A. Contractor shall provide competent, suitably qualified personnel to survey and lay out the Work and perform construction as required by the Contract Documents. Contractor shall at all times maintain good discipline and order at the Site.
- B. Except as otherwise required for the safety or protection of persons or the Work or property at the Site or adjacent thereto, and except as otherwise stated in the Contract Documents, all Work at the Site shall be performed during regular working hours. Contractor will not permit the performance of Work on a Saturday, Sunday, or any legal holiday without Owner’s written consent (which will not be unreasonably withheld) given after prior written notice to Engineer.

#### 6.03 *Services, Materials, and Equipment*

- A. Unless otherwise specified in the Contract Documents, Contractor shall provide and assume full responsibility for all services, materials, equipment, labor, transportation, construction equipment and machinery, tools, appliances, fuel, power, light, heat, telephone, water, sanitary facilities, temporary facilities, and all other facilities and incidentals necessary for the performance, testing, start-up, and completion of the Work.

- B. All materials and equipment incorporated into the Work shall be as specified or, if not specified, shall be of good quality and new, except as otherwise provided in the Contract Documents. All special warranties and guarantees required by the Specifications shall expressly run to the benefit of Owner. If required by Engineer, Contractor shall furnish satisfactory evidence (including reports of required tests) as to the source, kind, and quality of materials and equipment.
- C. All materials and equipment shall be stored, applied, installed, connected, erected, protected, used, cleaned, and conditioned in accordance with instructions of the applicable Supplier, except as otherwise may be provided in the Contract Documents.

#### 6.04 *Progress Schedule*

- A. Contractor shall adhere to the Progress Schedule established in accordance with Paragraph 2.07 as it may be adjusted from time to time as provided below.
  - 1. Contractor shall submit to Engineer for acceptance (to the extent indicated in Paragraph 2.07) proposed adjustments in the Progress Schedule that will not result in changing the Contract Times. Such adjustments will comply with any provisions of the General Requirements applicable thereto.
  - 2. Proposed adjustments in the Progress Schedule that will change the Contract Times shall be submitted in accordance with the requirements of Article 12. Adjustments in Contract Times may only be made by a Change Order.

#### 6.05 *Substitutes and "Or-Equals"*

- A. Whenever an item of material or equipment is specified or described in the Contract Documents by using the name of a proprietary item or the name of a particular Supplier, the specification or description is intended to establish the type, function, appearance, and quality required. Unless the specification or description contains or is followed by words reading that no like, equivalent, or "or-equal" item or no substitution is permitted, other items of material or equipment or material or equipment of other Suppliers may be submitted to Engineer for review under the circumstances described below.
  - 1. "*Or-Equal*" Items: If in Engineer's sole discretion an item of material or equipment proposed by Contractor is functionally equal to that named and sufficiently similar so that no change in related Work will be required, it may be considered by Engineer as an "or-equal" item, in which case review and approval of the proposed item may, in Engineer's sole discretion, be accomplished without compliance with some or all of the requirements for approval of proposed substitute items. For the purposes of this Paragraph 6.05.A.1, a proposed item of material or equipment will be considered functionally equal to an item so named if:
    - a. in the exercise of reasonable judgment Engineer determines that:
      - 1) it is at least equal in materials of construction, quality, durability, appearance, strength, and design characteristics;

- 2) it will reliably perform at least equally well the function and achieve the results imposed by the design concept of the completed Project as a functioning whole; and
  - 3) it has a proven record of performance and availability of responsive service.
- b. Contractor certifies that, if approved and incorporated into the Work:
- 1) there will be no increase in cost to the Owner or increase in Contract Times; and
  - 2) it will conform substantially to the detailed requirements of the item named in the Contract Documents.

2. *Substitute Items:*

- a. If in Engineer's sole discretion an item of material or equipment proposed by Contractor does not qualify as an "or-equal" item under Paragraph 6.05.A.1, it will be considered a proposed substitute item.
- b. Contractor shall submit sufficient information as provided below to allow Engineer to determine if the item of material or equipment proposed is essentially equivalent to that named and an acceptable substitute therefor. Requests for review of proposed substitute items of material or equipment will not be accepted by Engineer from anyone other than Contractor.
- c. The requirements for review by Engineer will be as set forth in Paragraph 6.05.A.2.d, as supplemented by the General Requirements, and as Engineer may decide is appropriate under the circumstances.
- d. Contractor shall make written application to Engineer for review of a proposed substitute item of material or equipment that Contractor seeks to furnish or use. The application:
  - 1) shall certify that the proposed substitute item will:
    - a) perform adequately the functions and achieve the results called for by the general design,
    - b) be similar in substance to that specified, and
    - c) be suited to the same use as that specified;
  - 2) will state:
    - a) the extent, if any, to which the use of the proposed substitute item will prejudice Contractor's achievement of Substantial Completion on time,
    - b) whether use of the proposed substitute item in the Work will require a change in any of the Contract Documents (or in the provisions of any other direct contract with Owner for other work on the Project) to adapt the design to the proposed substitute item, and

- c) whether incorporation or use of the proposed substitute item in connection with the Work is subject to payment of any license fee or royalty;
  - 3) will identify:
    - a) all variations of the proposed substitute item from that specified, and
    - b) available engineering, sales, maintenance, repair, and replacement services; and
  - 4) shall contain an itemized estimate of all costs or credits that will result directly or indirectly from use of such substitute item, including costs of redesign and claims of other contractors affected by any resulting change.
- B. *Substitute Construction Methods or Procedures:* If a specific means, method, technique, sequence, or procedure of construction is expressly required by the Contract Documents, Contractor may furnish or utilize a substitute means, method, technique, sequence, or procedure of construction approved by Engineer. Contractor shall submit sufficient information to allow Engineer, in Engineer's sole discretion, to determine that the substitute proposed is equivalent to that expressly called for by the Contract Documents. The requirements for review by Engineer will be similar to those provided in Paragraph 6.05.A.2.
- C. *Engineer's Evaluation:* Engineer will be allowed a reasonable time within which to evaluate each proposal or submittal made pursuant to Paragraphs 6.05.A and 6.05.B. Engineer may require Contractor to furnish additional data about the proposed substitute item. Engineer will be the sole judge of acceptability. No "or equal" or substitute will be ordered, installed or utilized until Engineer's review is complete, which will be evidenced by a Change Order in the case of a substitute and an approved Shop Drawing for an "or equal." Engineer will advise Contractor in writing of any negative determination.
- D. *Special Guarantee:* Owner may require Contractor to furnish at Contractor's expense a special performance guarantee or other surety with respect to any substitute.
- E. *Engineer's Cost Reimbursement:* Engineer will record Engineer's costs in evaluating a substitute proposed or submitted by Contractor pursuant to Paragraphs 6.05.A.2 and 6.05.B. Whether or not Engineer approves a substitute so proposed or submitted by Contractor, Contractor shall reimburse Owner for the reasonable charges of Engineer for evaluating each such proposed substitute. Contractor shall also reimburse Owner for the reasonable charges of Engineer for making changes in the Contract Documents (or in the provisions of any other direct contract with Owner) resulting from the acceptance of each proposed substitute.
- F. *Contractor's Expense:* Contractor shall provide all data in support of any proposed substitute or "or-equal" at Contractor's expense.

#### 6.06 *Concerning Subcontractors, Suppliers, and Others*

- A. Contractor shall not employ any Subcontractor, Supplier, or other individual or entity (including those acceptable to Owner as indicated in Paragraph 6.06.B), whether initially or as a replacement, against whom Owner may have reasonable objection. Contractor shall not be

required to employ any Subcontractor, Supplier, or other individual or entity to furnish or perform any of the Work against whom Contractor has reasonable objection.

- B. If the Supplementary Conditions require the identity of certain Subcontractors, Suppliers, or other individuals or entities to be submitted to Owner in advance for acceptance by Owner by a specified date prior to the Effective Date of the Agreement, and if Contractor has submitted a list thereof in accordance with the Supplementary Conditions, Owner's acceptance (either in writing or by failing to make written objection thereto by the date indicated for acceptance or objection in the Bidding Documents or the Contract Documents) of any such Subcontractor, Supplier, or other individual or entity so identified may be revoked on the basis of reasonable objection after due investigation. Contractor shall submit an acceptable replacement for the rejected Subcontractor, Supplier, or other individual or entity, and the Contract Price will be adjusted by the difference in the cost occasioned by such replacement, and an appropriate Change Order will be issued. No acceptance by Owner of any such Subcontractor, Supplier, or other individual or entity, whether initially or as a replacement, shall constitute a waiver of any right of Owner or Engineer to reject defective Work.
- C. Contractor shall be fully responsible to Owner and Engineer for all acts and omissions of the Subcontractors, Suppliers, and other individuals or entities performing or furnishing any of the Work just as Contractor is responsible for Contractor's own acts and omissions. Nothing in the Contract Documents:
1. shall create for the benefit of any such Subcontractor, Supplier, or other individual or entity any contractual relationship between Owner or Engineer and any such Subcontractor, Supplier or other individual or entity; nor
  2. shall create any obligation on the part of Owner or Engineer to pay or to see to the payment of any moneys due any such Subcontractor, Supplier, or other individual or entity except as may otherwise be required by Laws and Regulations.
- D. Contractor shall be solely responsible for scheduling and coordinating the Work of Subcontractors, Suppliers, and other individuals or entities performing or furnishing any of the Work under a direct or indirect contract with Contractor.
- E. Contractor shall require all Subcontractors, Suppliers, and such other individuals or entities performing or furnishing any of the Work to communicate with Engineer through Contractor.
- F. The divisions and sections of the Specifications and the identifications of any Drawings shall not control Contractor in dividing the Work among Subcontractors or Suppliers or delineating the Work to be performed by any specific trade.
- G. All Work performed for Contractor by a Subcontractor or Supplier will be pursuant to an appropriate agreement between Contractor and the Subcontractor or Supplier which specifically binds the Subcontractor or Supplier to the applicable terms and conditions of the Contract Documents for the benefit of Owner and Engineer. Whenever any such agreement is with a Subcontractor or Supplier who is listed as a loss payee on the property insurance provided in Paragraph 5.06, the agreement between the Contractor and the Subcontractor or Supplier will contain provisions whereby the Subcontractor or Supplier waives all rights against Owner,



Contractor, Engineer, and all other individuals or entities identified in the Supplementary Conditions to be listed as insureds or loss payees (and the officers, directors, members, partners, employees, agents, consultants, and subcontractors of each and any of them) for all losses and damages caused by, arising out of, relating to, or resulting from any of the perils or causes of loss covered by such policies and any other property insurance applicable to the Work. If the insurers on any such policies require separate waiver forms to be signed by any Subcontractor or Supplier, Contractor will obtain the same.

#### 6.07 *Patent Fees and Royalties*

- A. Contractor shall pay all license fees and royalties and assume all costs incident to the use in the performance of the Work or the incorporation in the Work of any invention, design, process, product, or device which is the subject of patent rights or copyrights held by others. If a particular invention, design, process, product, or device is specified in the Contract Documents for use in the performance of the Work and if, to the actual knowledge of Owner or Engineer, its use is subject to patent rights or copyrights calling for the payment of any license fee or royalty to others, the existence of such rights shall be disclosed by Owner in the Contract Documents.
- B. To the fullest extent permitted by Laws and Regulations, Owner shall indemnify and hold harmless Contractor, and its officers, directors, members, partners, employees, agents, consultants, and subcontractors from and against all claims, costs, losses, and damages (including but not limited to all fees and charges of engineers, architects, attorneys, and other professionals, and all court or arbitration or other dispute resolution costs) arising out of or relating to any infringement of patent rights or copyrights incident to the use in the performance of the Work or resulting from the incorporation in the Work of any invention, design, process, product, or device specified in the Contract Documents, but not identified as being subject to payment of any license fee or royalty to others required by patent rights or copyrights.
- C. To the fullest extent permitted by Laws and Regulations, Contractor shall indemnify and hold harmless Owner and Engineer, and the officers, directors, members, partners, employees, agents, consultants and subcontractors of each and any of them from and against all claims, costs, losses, and damages (including but not limited to all fees and charges of engineers, architects, attorneys, and other professionals and all court or arbitration or other dispute resolution costs) arising out of or relating to any infringement of patent rights or copyrights incident to the use in the performance of the Work or resulting from the incorporation in the Work of any invention, design, process, product, or device not specified in the Contract Documents.

#### 6.08 *Permits*

- A. Unless otherwise provided in the Supplementary Conditions, Contractor shall obtain and pay for all construction permits and licenses. Owner shall assist Contractor, when necessary, in obtaining such permits and licenses. Contractor shall pay all governmental charges and inspection fees necessary for the prosecution of the Work which are applicable at the time of opening of Bids, or, if there are no Bids, on the Effective Date of the Agreement. Owner shall pay all charges of utility owners for connections for providing permanent service to the Work.

## 6.09 *Laws and Regulations*

- A. Contractor shall give all notices required by and shall comply with all Laws and Regulations applicable to the performance of the Work. Except where otherwise expressly required by applicable Laws and Regulations, neither Owner nor Engineer shall be responsible for monitoring Contractor's compliance with any Laws or Regulations.
- B. If Contractor performs any Work knowing or having reason to know that it is contrary to Laws or Regulations, Contractor shall bear all claims, costs, losses, and damages (including but not limited to all fees and charges of engineers, architects, attorneys, and other professionals and all court or arbitration or other dispute resolution costs) arising out of or relating to such Work. However, it shall not be Contractor's responsibility to make certain that the Specifications and Drawings are in accordance with Laws and Regulations, but this shall not relieve Contractor of Contractor's obligations under Paragraph 3.03.
- C. Changes in Laws or Regulations not known at the time of opening of Bids (or, on the Effective Date of the Agreement if there were no Bids) having an effect on the cost or time of performance of the Work shall be the subject of an adjustment in Contract Price or Contract Times. If Owner and Contractor are unable to agree on entitlement to or on the amount or extent, if any, of any such adjustment, a Claim may be made therefor as provided in Paragraph 10.05.

## 6.10 *Taxes*

- A. Contractor shall pay all sales, consumer, use, and other similar taxes required to be paid by Contractor in accordance with the Laws and Regulations of the place of the Project which are applicable during the performance of the Work.

## 6.11 *Use of Site and Other Areas*

### A. *Limitation on Use of Site and Other Areas:*

1. Contractor shall confine construction equipment, the storage of materials and equipment, and the operations of workers to the Site and other areas permitted by Laws and Regulations, and shall not unreasonably encumber the Site and other areas with construction equipment or other materials or equipment. Contractor shall assume full responsibility for any damage to any such land or area, or to the owner or occupant thereof, or of any adjacent land or areas resulting from the performance of the Work.
2. Should any claim be made by any such owner or occupant because of the performance of the Work, Contractor shall promptly settle with such other party by negotiation or otherwise resolve the claim by arbitration or other dispute resolution proceeding or at law.
3. To the fullest extent permitted by Laws and Regulations, Contractor shall indemnify and hold harmless Owner and Engineer, and the officers, directors, members, partners, employees, agents, consultants and subcontractors of each and any of them from and against all claims, costs, losses, and damages (including but not limited to all fees and charges of engineers, architects, attorneys, and other professionals and all court or arbitration or other dispute resolution costs) arising out of or relating to any claim or action, legal or equitable, brought

by any such owner or occupant against Owner, Engineer, or any other party indemnified hereunder to the extent caused by or based upon Contractor's performance of the Work.

- B. *Removal of Debris During Performance of the Work:* During the progress of the Work Contractor shall keep the Site and other areas free from accumulations of waste materials, rubbish, and other debris. Removal and disposal of such waste materials, rubbish, and other debris shall conform to applicable Laws and Regulations.
- C. *Cleaning:* Prior to Substantial Completion of the Work Contractor shall clean the Site and the Work and make it ready for utilization by Owner. At the completion of the Work Contractor shall remove from the Site all tools, appliances, construction equipment and machinery, and surplus materials and shall restore to original condition all property not designated for alteration by the Contract Documents.
- D. *Loading Structures:* Contractor shall not load nor permit any part of any structure to be loaded in any manner that will endanger the structure, nor shall Contractor subject any part of the Work or adjacent property to stresses or pressures that will endanger it.

#### 6.12 *Record Documents*

- A. Contractor shall maintain in a safe place at the Site one record copy of all Drawings, Specifications, Addenda, Change Orders, Work Change Directives, Field Orders, and written interpretations and clarifications in good order and annotated to show changes made during construction. These record documents together with all approved Samples and a counterpart of all approved Shop Drawings will be available to Engineer for reference. Upon completion of the Work, these record documents, Samples, and Shop Drawings will be delivered to Engineer for Owner.

#### 6.13 *Safety and Protection*

- A. Contractor shall be solely responsible for initiating, maintaining and supervising all safety precautions and programs in connection with the Work. Such responsibility does not relieve Subcontractors of their responsibility for the safety of persons or property in the performance of their work, nor for compliance with applicable safety Laws and Regulations. Contractor shall take all necessary precautions for the safety of, and shall provide the necessary protection to prevent damage, injury or loss to:
  - 1. all persons on the Site or who may be affected by the Work;
  - 2. all the Work and materials and equipment to be incorporated therein, whether in storage on or off the Site; and
  - 3. other property at the Site or adjacent thereto, including trees, shrubs, lawns, walks, pavements, roadways, structures, utilities, and Underground Facilities not designated for removal, relocation, or replacement in the course of construction.
- B. Contractor shall comply with all applicable Laws and Regulations relating to the safety of persons or property, or to the protection of persons or property from damage, injury, or loss; and

shall erect and maintain all necessary safeguards for such safety and protection. Contractor shall notify owners of adjacent property and of Underground Facilities and other utility owners when prosecution of the Work may affect them, and shall cooperate with them in the protection, removal, relocation, and replacement of their property.

- C. Contractor shall comply with the applicable requirements of Owner's safety programs, if any. The Supplementary Conditions identify any Owner's safety programs that are applicable to the Work.
- D. Contractor shall inform Owner and Engineer of the specific requirements of Contractor's safety program with which Owner's and Engineer's employees and representatives must comply while at the Site.
- E. All damage, injury, or loss to any property referred to in Paragraph 6.13.A.2 or 6.13.A.3 caused, directly or indirectly, in whole or in part, by Contractor, any Subcontractor, Supplier, or any other individual or entity directly or indirectly employed by any of them to perform any of the Work, or anyone for whose acts any of them may be liable, shall be remedied by Contractor (except damage or loss attributable to the fault of Drawings or Specifications or to the acts or omissions of Owner or Engineer or anyone employed by any of them, or anyone for whose acts any of them may be liable, and not attributable, directly or indirectly, in whole or in part, to the fault or negligence of Contractor or any Subcontractor, Supplier, or other individual or entity directly or indirectly employed by any of them).
- F. Contractor's duties and responsibilities for safety and for protection of the Work shall continue until such time as all the Work is completed and Engineer has issued a notice to Owner and Contractor in accordance with Paragraph 14.07.B that the Work is acceptable (except as otherwise expressly provided in connection with Substantial Completion).

#### 6.14 *Safety Representative*

- A. Contractor shall designate a qualified and experienced safety representative at the Site whose duties and responsibilities shall be the prevention of accidents and the maintaining and supervising of safety precautions and programs.

#### 6.15 *Hazard Communication Programs*

- A. Contractor shall be responsible for coordinating any exchange of material safety data sheets or other hazard communication information required to be made available to or exchanged between or among employers at the Site in accordance with Laws or Regulations.

#### 6.16 *Emergencies*

- A. In emergencies affecting the safety or protection of persons or the Work or property at the Site or adjacent thereto, Contractor is obligated to act to prevent threatened damage, injury, or loss. Contractor shall give Engineer prompt written notice if Contractor believes that any significant changes in the Work or variations from the Contract Documents have been caused thereby or are required as a result thereof. If Engineer determines that a change in the Contract Documents is

required because of the action taken by Contractor in response to such an emergency, a Work Change Directive or Change Order will be issued.

#### 6.17 *Shop Drawings and Samples*

A. Contractor shall submit Shop Drawings and Samples to Engineer for review and approval in accordance with the accepted Schedule of Submittals (as required by Paragraph 2.07). Each submittal will be identified as Engineer may require.

##### 1. *Shop Drawings:*

- a. Submit number of copies specified in the General Requirements.
- b. Data shown on the Shop Drawings will be complete with respect to quantities, dimensions, specified performance and design criteria, materials, and similar data to show Engineer the services, materials, and equipment Contractor proposes to provide and to enable Engineer to review the information for the limited purposes required by Paragraph 6.17.D.

##### 2. *Samples:*

- a. Submit number of Samples specified in the Specifications.
- b. Clearly identify each Sample as to material, Supplier, pertinent data such as catalog numbers, the use for which intended and other data as Engineer may require to enable Engineer to review the submittal for the limited purposes required by Paragraph 6.17.D.

B. Where a Shop Drawing or Sample is required by the Contract Documents or the Schedule of Submittals, any related Work performed prior to Engineer's review and approval of the pertinent submittal will be at the sole expense and responsibility of Contractor.

##### C. *Submittal Procedures:*

##### 1. Before submitting each Shop Drawing or Sample, Contractor shall have:

- a. reviewed and coordinated each Shop Drawing or Sample with other Shop Drawings and Samples and with the requirements of the Work and the Contract Documents;
- b. determined and verified all field measurements, quantities, dimensions, specified performance and design criteria, installation requirements, materials, catalog numbers, and similar information with respect thereto;
- c. determined and verified the suitability of all materials offered with respect to the indicated application, fabrication, shipping, handling, storage, assembly, and installation pertaining to the performance of the Work; and
- d. determined and verified all information relative to Contractor's responsibilities for means, methods, techniques, sequences, and procedures of construction, and safety precautions and programs incident thereto.

2. Each submittal shall bear a stamp or specific written certification that Contractor has satisfied Contractor's obligations under the Contract Documents with respect to Contractor's review and approval of that submittal.
3. With each submittal, Contractor shall give Engineer specific written notice of any variations that the Shop Drawing or Sample may have from the requirements of the Contract Documents. This notice shall be both a written communication separate from the Shop Drawings or Sample submittal; and, in addition, by a specific notation made on each Shop Drawing or Sample submitted to Engineer for review and approval of each such variation.

D. *Engineer's Review:*

1. Engineer will provide timely review of Shop Drawings and Samples in accordance with the Schedule of Submittals acceptable to Engineer. Engineer's review and approval will be only to determine if the items covered by the submittals will, after installation or incorporation in the Work, conform to the information given in the Contract Documents and be compatible with the design concept of the completed Project as a functioning whole as indicated by the Contract Documents.
2. Engineer's review and approval will not extend to means, methods, techniques, sequences, or procedures of construction (except where a particular means, method, technique, sequence, or procedure of construction is specifically and expressly called for by the Contract Documents) or to safety precautions or programs incident thereto. The review and approval of a separate item as such will not indicate approval of the assembly in which the item functions.
3. Engineer's review and approval shall not relieve Contractor from responsibility for any variation from the requirements of the Contract Documents unless Contractor has complied with the requirements of Paragraph 6.17.C.3 and Engineer has given written approval of each such variation by specific written notation thereof incorporated in or accompanying the Shop Drawing or Sample. Engineer's review and approval shall not relieve Contractor from responsibility for complying with the requirements of Paragraph 6.17.C.1.

E. *Resubmittal Procedures:*

1. Contractor shall make corrections required by Engineer and shall return the required number of corrected copies of Shop Drawings and submit, as required, new Samples for review and approval. Contractor shall direct specific attention in writing to revisions other than the corrections called for by Engineer on previous submittals.

6.18 *Continuing the Work*

- A. Contractor shall carry on the Work and adhere to the Progress Schedule during all disputes or disagreements with Owner. No Work shall be delayed or postponed pending resolution of any disputes or disagreements, except as permitted by Paragraph 15.04 or as Owner and Contractor may otherwise agree in writing.

## 6.19 *Contractor's General Warranty and Guarantee*

- A. Contractor warrants and guarantees to Owner that all Work will be in accordance with the Contract Documents and will not be defective. Engineer and its officers, directors, members, partners, employees, agents, consultants, and subcontractors shall be entitled to rely on representation of Contractor's warranty and guarantee.
- B. Contractor's warranty and guarantee hereunder excludes defects or damage caused by:
  - 1. abuse, modification, or improper maintenance or operation by persons other than Contractor, Subcontractors, Suppliers, or any other individual or entity for whom Contractor is responsible; or
  - 2. normal wear and tear under normal usage.
- C. Contractor's obligation to perform and complete the Work in accordance with the Contract Documents shall be absolute. None of the following will constitute an acceptance of Work that is not in accordance with the Contract Documents or a release of Contractor's obligation to perform the Work in accordance with the Contract Documents:
  - 1. observations by Engineer;
  - 2. recommendation by Engineer or payment by Owner of any progress or final payment;
  - 3. the issuance of a certificate of Substantial Completion by Engineer or any payment related thereto by Owner;
  - 4. use or occupancy of the Work or any part thereof by Owner;
  - 5. any review and approval of a Shop Drawing or Sample submittal or the issuance of a notice of acceptability by Engineer;
  - 6. any inspection, test, or approval by others; or
  - 7. any correction of defective Work by Owner.

## 6.20 *Indemnification*

- A. To the fullest extent permitted by Laws and Regulations, Contractor shall indemnify and hold harmless Owner and Engineer, and the officers, directors, members, partners, employees, agents, consultants and subcontractors of each and any of them from and against all claims, costs, losses, and damages (including but not limited to all fees and charges of engineers, architects, attorneys, and other professionals and all court or arbitration or other dispute resolution costs) arising out of or relating to the performance of the Work, provided that any such claim, cost, loss, or damage is attributable to bodily injury, sickness, disease, or death, or to injury to or destruction of tangible property (other than the Work itself), including the loss of use resulting therefrom but only to the extent caused by any negligent act or omission of Contractor, any Subcontractor, any Supplier, or any individual or entity directly or indirectly employed by any of them to perform any of the Work or anyone for whose acts any of them may be liable .

- B. In any and all claims against Owner or Engineer or any of their officers, directors, members, partners, employees, agents, consultants, or subcontractors by any employee (or the survivor or personal representative of such employee) of Contractor, any Subcontractor, any Supplier, or any individual or entity directly or indirectly employed by any of them to perform any of the Work, or anyone for whose acts any of them may be liable, the indemnification obligation under Paragraph 6.20.A shall not be limited in any way by any limitation on the amount or type of damages, compensation, or benefits payable by or for Contractor or any such Subcontractor, Supplier, or other individual or entity under workers' compensation acts, disability benefit acts, or other employee benefit acts.
- C. The indemnification obligations of Contractor under Paragraph 6.20.A shall not extend to the liability of Engineer and Engineer's officers, directors, members, partners, employees, agents, consultants and subcontractors arising out of:
  - 1. the preparation or approval of, or the failure to prepare or approve maps, Drawings, opinions, reports, surveys, Change Orders, designs, or Specifications; or
  - 2. giving directions or instructions, or failing to give them, if that is the primary cause of the injury or damage.

#### 6.21 *Delegation of Professional Design Services*

- A. Contractor will not be required to provide professional design services unless such services are specifically required by the Contract Documents for a portion of the Work or unless such services are required to carry out Contractor's responsibilities for construction means, methods, techniques, sequences and procedures. Contractor shall not be required to provide professional services in violation of applicable law.
- B. If professional design services or certifications by a design professional related to systems, materials or equipment are specifically required of Contractor by the Contract Documents, Owner and Engineer will specify all performance and design criteria that such services must satisfy. Contractor shall cause such services or certifications to be provided by a properly licensed professional, whose signature and seal shall appear on all drawings, calculations, specifications, certifications, Shop Drawings and other submittals prepared by such professional. Shop Drawings and other submittals related to the Work designed or certified by such professional, if prepared by others, shall bear such professional's written approval when submitted to Engineer.
- C. Owner and Engineer shall be entitled to rely upon the adequacy, accuracy and completeness of the services, certifications or approvals performed by such design professionals, provided Owner and Engineer have specified to Contractor all performance and design criteria that such services must satisfy.
- D. Pursuant to this Paragraph 6.21, Engineer's review and approval of design calculations and design drawings will be only for the limited purpose of checking for conformance with performance and design criteria given and the design concept expressed in the Contract Documents. Engineer's review and approval of Shop Drawings and other submittals (except design calculations and design drawings) will be only for the purpose stated in Paragraph 6.17.D.1.



- E. Contractor shall not be responsible for the adequacy of the performance or design criteria required by the Contract Documents.

## **ARTICLE 7 – OTHER WORK AT THE SITE**

### *7.01 Related Work at Site*

- A. Owner may perform other work related to the Project at the Site with Owner’s employees, or through other direct contracts therefor, or have other work performed by utility owners. If such other work is not noted in the Contract Documents, then:
  - 1. written notice thereof will be given to Contractor prior to starting any such other work; and
  - 2. if Owner and Contractor are unable to agree on entitlement to or on the amount or extent, if any, of any adjustment in the Contract Price or Contract Times that should be allowed as a result of such other work, a Claim may be made therefor as provided in Paragraph 10.05.
- B. Contractor shall afford each other contractor who is a party to such a direct contract, each utility owner, and Owner, if Owner is performing other work with Owner’s employees, proper and safe access to the Site, provide a reasonable opportunity for the introduction and storage of materials and equipment and the execution of such other work, and properly coordinate the Work with theirs. Contractor shall do all cutting, fitting, and patching of the Work that may be required to properly connect or otherwise make its several parts come together and properly integrate with such other work. Contractor shall not endanger any work of others by cutting, excavating, or otherwise altering such work; provided, however, that Contractor may cut or alter others' work with the written consent of Engineer and the others whose work will be affected. The duties and responsibilities of Contractor under this Paragraph are for the benefit of such utility owners and other contractors to the extent that there are comparable provisions for the benefit of Contractor in said direct contracts between Owner and such utility owners and other contractors.
- C. If the proper execution or results of any part of Contractor’s Work depends upon work performed by others under this Article 7, Contractor shall inspect such other work and promptly report to Engineer in writing any delays, defects, or deficiencies in such other work that render it unavailable or unsuitable for the proper execution and results of Contractor’s Work. Contractor’s failure to so report will constitute an acceptance of such other work as fit and proper for integration with Contractor’s Work except for latent defects and deficiencies in such other work.

### *7.02 Coordination*

- A. If Owner intends to contract with others for the performance of other work on the Project at the Site, the following will be set forth in Supplementary Conditions:
  - 1. the individual or entity who will have authority and responsibility for coordination of the activities among the various contractors will be identified;
  - 2. the specific matters to be covered by such authority and responsibility will be itemized; and
  - 3. the extent of such authority and responsibilities will be provided.

- B. Unless otherwise provided in the Supplementary Conditions, Owner shall have sole authority and responsibility for such coordination.

7.03 *Legal Relationships*

- A. Paragraphs 7.01.A and 7.02 are not applicable for utilities not under the control of Owner.
- B. Each other direct contract of Owner under Paragraph 7.01.A shall provide that the other contractor is liable to Owner and Contractor for the reasonable direct delay and disruption costs incurred by Contractor as a result of the other contractor's wrongful actions or inactions.
- C. Contractor shall be liable to Owner and any other contractor under direct contract to Owner for the reasonable direct delay and disruption costs incurred by such other contractor as a result of Contractor's wrongful action or inactions.

**ARTICLE 8 – OWNER'S RESPONSIBILITIES**

8.01 *Communications to Contractor*

- A. Except as otherwise provided in these General Conditions, Owner shall issue all communications to Contractor through Engineer.

8.02 *Replacement of Engineer*

- A. In case of termination of the employment of Engineer, Owner shall appoint an engineer to whom Contractor makes no reasonable objection, whose status under the Contract Documents shall be that of the former Engineer.

8.03 *Furnish Data*

- A. Owner shall promptly furnish the data required of Owner under the Contract Documents.

8.04 *Pay When Due*

- A. Owner shall make payments to Contractor when they are due as provided in Paragraphs 14.02.C and 14.07.C.

8.05 *Lands and Easements; Reports and Tests*

- A. Owner's duties with respect to providing lands and easements and providing engineering surveys to establish reference points are set forth in Paragraphs 4.01 and 4.05. Paragraph 4.02 refers to Owner's identifying and making available to Contractor copies of reports of explorations and tests of subsurface conditions and drawings of physical conditions relating to existing surface or subsurface structures at the Site.

8.06 *Insurance*

- A. Owner's responsibilities, if any, with respect to purchasing and maintaining liability and property insurance are set forth in Article 5.

8.07 *Change Orders*

A. Owner is obligated to execute Change Orders as indicated in Paragraph 10.03.

8.08 *Inspections, Tests, and Approvals*

A. Owner's responsibility with respect to certain inspections, tests, and approvals is set forth in Paragraph 13.03.B.

8.09 *Limitations on Owner's Responsibilities*

A. The Owner shall not supervise, direct, or have control or authority over, nor be responsible for, Contractor's means, methods, techniques, sequences, or procedures of construction, or the safety precautions and programs incident thereto, or for any failure of Contractor to comply with Laws and Regulations applicable to the performance of the Work. Owner will not be responsible for Contractor's failure to perform the Work in accordance with the Contract Documents.

8.10 *Undisclosed Hazardous Environmental Condition*

A. Owner's responsibility in respect to an undisclosed Hazardous Environmental Condition is set forth in Paragraph 4.06.

8.11 *Evidence of Financial Arrangements*

A. Upon request of Contractor, Owner shall furnish Contractor reasonable evidence that financial arrangements have been made to satisfy Owner's obligations under the Contract Documents.

8.12 *Compliance with Safety Program*

A. While at the Site, Owner's employees and representatives shall comply with the specific applicable requirements of Contractor's safety programs of which Owner has been informed pursuant to Paragraph 6.13.D.

**ARTICLE 9 – ENGINEER'S STATUS DURING CONSTRUCTION**

9.01 *Owner's Representative*

A. Engineer will be Owner's representative during the construction period. The duties and responsibilities and the limitations of authority of Engineer as Owner's representative during construction are set forth in the Contract Documents.

9.02 *Visits to Site*

A. Engineer will make visits to the Site at intervals appropriate to the various stages of construction as Engineer deems necessary in order to observe as an experienced and qualified design professional the progress that has been made and the quality of the various aspects of Contractor's executed Work. Based on information obtained during such visits and observations, Engineer, for the benefit of Owner, will determine, in general, if the Work is proceeding in accordance with the Contract Documents. Engineer will not be required to make exhaustive or

continuous inspections on the Site to check the quality or quantity of the Work. Engineer's efforts will be directed toward providing for Owner a greater degree of confidence that the completed Work will conform generally to the Contract Documents. On the basis of such visits and observations, Engineer will keep Owner informed of the progress of the Work and will endeavor to guard Owner against defective Work.

- B. Engineer's visits and observations are subject to all the limitations on Engineer's authority and responsibility set forth in Paragraph 9.09. Particularly, but without limitation, during or as a result of Engineer's visits or observations of Contractor's Work, Engineer will not supervise, direct, control, or have authority over or be responsible for Contractor's means, methods, techniques, sequences, or procedures of construction, or the safety precautions and programs incident thereto, or for any failure of Contractor to comply with Laws and Regulations applicable to the performance of the Work.

#### 9.03 *Project Representative*

- A. If Owner and Engineer agree, Engineer will furnish a Resident Project Representative to assist Engineer in providing more extensive observation of the Work. The authority and responsibilities of any such Resident Project Representative and assistants will be as provided in the Supplementary Conditions, and limitations on the responsibilities thereof will be as provided in Paragraph 9.09. If Owner designates another representative or agent to represent Owner at the Site who is not Engineer's consultant, agent or employee, the responsibilities and authority and limitations thereon of such other individual or entity will be as provided in the Supplementary Conditions.

#### 9.04 *Authorized Variations in Work*

- A. Engineer may authorize minor variations in the Work from the requirements of the Contract Documents which do not involve an adjustment in the Contract Price or the Contract Times and are compatible with the design concept of the completed Project as a functioning whole as indicated by the Contract Documents. These may be accomplished by a Field Order and will be binding on Owner and also on Contractor, who shall perform the Work involved promptly. If Owner or Contractor believes that a Field Order justifies an adjustment in the Contract Price or Contract Times, or both, and the parties are unable to agree on entitlement to or on the amount or extent, if any, of any such adjustment, a Claim may be made therefor as provided in Paragraph 10.05.

#### 9.05 *Rejecting Defective Work*

- A. Engineer will have authority to reject Work which Engineer believes to be defective, or that Engineer believes will not produce a completed Project that conforms to the Contract Documents or that will prejudice the integrity of the design concept of the completed Project as a functioning whole as indicated by the Contract Documents. Engineer will also have authority to require special inspection or testing of the Work as provided in Paragraph 13.04, whether or not the Work is fabricated, installed, or completed.

9.06 *Shop Drawings, Change Orders and Payments*

- A. In connection with Engineer's authority, and limitations thereof, as to Shop Drawings and Samples, see Paragraph 6.17.
- B. In connection with Engineer's authority, and limitations thereof, as to design calculations and design drawings submitted in response to a delegation of professional design services, if any, see Paragraph 6.21.
- C. In connection with Engineer's authority as to Change Orders, see Articles 10, 11, and 12.
- D. In connection with Engineer's authority as to Applications for Payment, see Article 14.

9.07 *Determinations for Unit Price Work*

- A. Engineer will determine the actual quantities and classifications of Unit Price Work performed by Contractor. Engineer will review with Contractor the Engineer's preliminary determinations on such matters before rendering a written decision thereon (by recommendation of an Application for Payment or otherwise). Engineer's written decision thereon will be final and binding (except as modified by Engineer to reflect changed factual conditions or more accurate data) upon Owner and Contractor, subject to the provisions of Paragraph 10.05.

9.08 *Decisions on Requirements of Contract Documents and Acceptability of Work*

- A. Engineer will be the initial interpreter of the requirements of the Contract Documents and judge of the acceptability of the Work thereunder. All matters in question and other matters between Owner and Contractor arising prior to the date final payment is due relating to the acceptability of the Work, and the interpretation of the requirements of the Contract Documents pertaining to the performance of the Work, will be referred initially to Engineer in writing within 30 days of the event giving rise to the question.
- B. Engineer will, with reasonable promptness, render a written decision on the issue referred. If Owner or Contractor believes that any such decision entitles them to an adjustment in the Contract Price or Contract Times or both, a Claim may be made under Paragraph 10.05. The date of Engineer's decision shall be the date of the event giving rise to the issues referenced for the purposes of Paragraph 10.05.B.
- C. Engineer's written decision on the issue referred will be final and binding on Owner and Contractor, subject to the provisions of Paragraph 10.05.
- D. When functioning as interpreter and judge under this Paragraph 9.08, Engineer will not show partiality to Owner or Contractor and will not be liable in connection with any interpretation or decision rendered in good faith in such capacity.

9.09 *Limitations on Engineer's Authority and Responsibilities*

- A. Neither Engineer's authority or responsibility under this Article 9 or under any other provision of the Contract Documents nor any decision made by Engineer in good faith either to exercise or not

exercise such authority or responsibility or the undertaking, exercise, or performance of any authority or responsibility by Engineer shall create, impose, or give rise to any duty in contract, tort, or otherwise owed by Engineer to Contractor, any Subcontractor, any Supplier, any other individual or entity, or to any surety for or employee or agent of any of them.

- B. Engineer will not supervise, direct, control, or have authority over or be responsible for Contractor's means, methods, techniques, sequences, or procedures of construction, or the safety precautions and programs incident thereto, or for any failure of Contractor to comply with Laws and Regulations applicable to the performance of the Work. Engineer will not be responsible for Contractor's failure to perform the Work in accordance with the Contract Documents.
- C. Engineer will not be responsible for the acts or omissions of Contractor or of any Subcontractor, any Supplier, or of any other individual or entity performing any of the Work.
- D. Engineer's review of the final Application for Payment and accompanying documentation and all maintenance and operating instructions, schedules, guarantees, bonds, certificates of inspection, tests and approvals, and other documentation required to be delivered by Paragraph 14.07.A will only be to determine generally that their content complies with the requirements of, and in the case of certificates of inspections, tests, and approvals that the results certified indicate compliance with, the Contract Documents.
- E. The limitations upon authority and responsibility set forth in this Paragraph 9.09 shall also apply to the Resident Project Representative, if any, and assistants, if any.

#### 9.10 *Compliance with Safety Program*

- A. While at the Site, Engineer's employees and representatives shall comply with the specific applicable requirements of Contractor's safety programs of which Engineer has been informed pursuant to Paragraph 6.13.D.

### **ARTICLE 10 – CHANGES IN THE WORK; CLAIMS**

#### 10.01 *Authorized Changes in the Work*

- A. Without invalidating the Contract and without notice to any surety, Owner may, at any time or from time to time, order additions, deletions, or revisions in the Work by a Change Order, or a Work Change Directive. Upon receipt of any such document, Contractor shall promptly proceed with the Work involved which will be performed under the applicable conditions of the Contract Documents (except as otherwise specifically provided).
- B. If Owner and Contractor are unable to agree on entitlement to, or on the amount or extent, if any, of an adjustment in the Contract Price or Contract Times, or both, that should be allowed as a result of a Work Change Directive, a Claim may be made therefor as provided in Paragraph 10.05.

## 10.02 *Unauthorized Changes in the Work*

- A. Contractor shall not be entitled to an increase in the Contract Price or an extension of the Contract Times with respect to any work performed that is not required by the Contract Documents as amended, modified, or supplemented as provided in Paragraph 3.04, except in the case of an emergency as provided in Paragraph 6.16 or in the case of uncovering Work as provided in Paragraph 13.04.D.

## 10.03 *Execution of Change Orders*

- A. Owner and Contractor shall execute appropriate Change Orders recommended by Engineer covering:
  - 1. changes in the Work which are: (i) ordered by Owner pursuant to Paragraph 10.01.A, (ii) required because of acceptance of defective Work under Paragraph 13.08.A or Owner's correction of defective Work under Paragraph 13.09, or (iii) agreed to by the parties;
  - 2. changes in the Contract Price or Contract Times which are agreed to by the parties, including any undisputed sum or amount of time for Work actually performed in accordance with a Work Change Directive; and
  - 3. changes in the Contract Price or Contract Times which embody the substance of any written decision rendered by Engineer pursuant to Paragraph 10.05; provided that, in lieu of executing any such Change Order, an appeal may be taken from any such decision in accordance with the provisions of the Contract Documents and applicable Laws and Regulations, but during any such appeal, Contractor shall carry on the Work and adhere to the Progress Schedule as provided in Paragraph 6.18.A.

## 10.04 *Notification to Surety*

- A. If the provisions of any bond require notice to be given to a surety of any change affecting the general scope of the Work or the provisions of the Contract Documents (including, but not limited to, Contract Price or Contract Times), the giving of any such notice will be Contractor's responsibility. The amount of each applicable bond will be adjusted to reflect the effect of any such change.

## 10.05 *Claims*

- A. *Engineer's Decision Required:* All Claims, except those waived pursuant to Paragraph 14.09, shall be referred to the Engineer for decision. A decision by Engineer shall be required as a condition precedent to any exercise by Owner or Contractor of any rights or remedies either may otherwise have under the Contract Documents or by Laws and Regulations in respect of such Claims.
- B. *Notice:* Written notice stating the general nature of each Claim shall be delivered by the claimant to Engineer and the other party to the Contract promptly (but in no event later than 30 days) after the start of the event giving rise thereto. The responsibility to substantiate a Claim shall rest with the party making the Claim. Notice of the amount or extent of the Claim, with supporting data

shall be delivered to the Engineer and the other party to the Contract within 60 days after the start of such event (unless Engineer allows additional time for claimant to submit additional or more accurate data in support of such Claim). A Claim for an adjustment in Contract Price shall be prepared in accordance with the provisions of Paragraph 12.01.B. A Claim for an adjustment in Contract Times shall be prepared in accordance with the provisions of Paragraph 12.02.B. Each Claim shall be accompanied by claimant's written statement that the adjustment claimed is the entire adjustment to which the claimant believes it is entitled as a result of said event. The opposing party shall submit any response to Engineer and the claimant within 30 days after receipt of the claimant's last submittal (unless Engineer allows additional time).

- C. *Engineer's Action:* Engineer will review each Claim and, within 30 days after receipt of the last submittal of the claimant or the last submittal of the opposing party, if any, take one of the following actions in writing:
1. deny the Claim in whole or in part;
  2. approve the Claim; or
  3. notify the parties that the Engineer is unable to resolve the Claim if, in the Engineer's sole discretion, it would be inappropriate for the Engineer to do so. For purposes of further resolution of the Claim, such notice shall be deemed a denial.
- D. In the event that Engineer does not take action on a Claim within said 30 days, the Claim shall be deemed denied.
- E. Engineer's written action under Paragraph 10.05.C or denial pursuant to Paragraphs 10.05.C.3 or 10.05.D will be final and binding upon Owner and Contractor, unless Owner or Contractor invoke the dispute resolution procedure set forth in Article 16 within 30 days of such action or denial.
- F. No Claim for an adjustment in Contract Price or Contract Times will be valid if not submitted in accordance with this Paragraph 10.05.

## **ARTICLE 11 – COST OF THE WORK; ALLOWANCES; UNIT PRICE WORK**

### **11.01 *Cost of the Work***

- A. *Costs Included:* The term Cost of the Work means the sum of all costs, except those excluded in Paragraph 11.01.B, necessarily incurred and paid by Contractor in the proper performance of the Work. When the value of any Work covered by a Change Order or when a Claim for an adjustment in Contract Price is determined on the basis of Cost of the Work, the costs to be reimbursed to Contractor will be only those additional or incremental costs required because of the change in the Work or because of the event giving rise to the Claim. Except as otherwise may be agreed to in writing by Owner, such costs shall be in amounts no higher than those prevailing in the locality of the Project, shall not include any of the costs itemized in Paragraph 11.01.B, and shall include only the following items:



1. Payroll costs for employees in the direct employ of Contractor in the performance of the Work under schedules of job classifications agreed upon by Owner and Contractor. Such employees shall include, without limitation, superintendents, foremen, and other personnel employed full time on the Work. Payroll costs for employees not employed full time on the Work shall be apportioned on the basis of their time spent on the Work. Payroll costs shall include, but not be limited to, salaries and wages plus the cost of fringe benefits, which shall include social security contributions, unemployment, excise, and payroll taxes, workers' compensation, health and retirement benefits, bonuses, sick leave, vacation and holiday pay applicable thereto. The expenses of performing Work outside of regular working hours, on Saturday, Sunday, or legal holidays, shall be included in the above to the extent authorized by Owner.
2. Cost of all materials and equipment furnished and incorporated in the Work, including costs of transportation and storage thereof, and Suppliers' field services required in connection therewith. All cash discounts shall accrue to Contractor unless Owner deposits funds with Contractor with which to make payments, in which case the cash discounts shall accrue to Owner. All trade discounts, rebates and refunds and returns from sale of surplus materials and equipment shall accrue to Owner, and Contractor shall make provisions so that they may be obtained.
3. Payments made by Contractor to Subcontractors for Work performed by Subcontractors. If required by Owner, Contractor shall obtain competitive bids from subcontractors acceptable to Owner and Contractor and shall deliver such bids to Owner, who will then determine, with the advice of Engineer, which bids, if any, will be acceptable. If any subcontract provides that the Subcontractor is to be paid on the basis of Cost of the Work plus a fee, the Subcontractor's Cost of the Work and fee shall be determined in the same manner as Contractor's Cost of the Work and fee as provided in this Paragraph 11.01.
4. Costs of special consultants (including but not limited to engineers, architects, testing laboratories, surveyors, attorneys, and accountants) employed for services specifically related to the Work.
5. Supplemental costs including the following:
  - a. The proportion of necessary transportation, travel, and subsistence expenses of Contractor's employees incurred in discharge of duties connected with the Work.
  - b. Cost, including transportation and maintenance, of all materials, supplies, equipment, machinery, appliances, office, and temporary facilities at the Site, and hand tools not owned by the workers, which are consumed in the performance of the Work, and cost, less market value, of such items used but not consumed which remain the property of Contractor.
  - c. Rentals of all construction equipment and machinery, and the parts thereof whether rented from Contractor or others in accordance with rental agreements approved by Owner with the advice of Engineer, and the costs of transportation, loading, unloading, assembly, dismantling, and removal thereof. All such costs shall be in accordance with the terms of

said rental agreements. The rental of any such equipment, machinery, or parts shall cease when the use thereof is no longer necessary for the Work.

- d. Sales, consumer, use, and other similar taxes related to the Work, and for which Contractor is liable, as imposed by Laws and Regulations.
- e. Deposits lost for causes other than negligence of Contractor, any Subcontractor, or anyone directly or indirectly employed by any of them or for whose acts any of them may be liable, and royalty payments and fees for permits and licenses.
- f. Losses and damages (and related expenses) caused by damage to the Work, not compensated by insurance or otherwise, sustained by Contractor in connection with the performance of the Work (except losses and damages within the deductible amounts of property insurance established in accordance with Paragraph 5.06.D), provided such losses and damages have resulted from causes other than the negligence of Contractor, any Subcontractor, or anyone directly or indirectly employed by any of them or for whose acts any of them may be liable. Such losses shall include settlements made with the written consent and approval of Owner. No such losses, damages, and expenses shall be included in the Cost of the Work for the purpose of determining Contractor's fee.
- g. The cost of utilities, fuel, and sanitary facilities at the Site.
- h. Minor expenses such as telegrams, long distance telephone calls, telephone service at the Site, express and courier services, and similar petty cash items in connection with the Work.
- i. The costs of premiums for all bonds and insurance Contractor is required by the Contract Documents to purchase and maintain.

B. *Costs Excluded:* The term Cost of the Work shall not include any of the following items:

1. Payroll costs and other compensation of Contractor's officers, executives, principals (of partnerships and sole proprietorships), general managers, safety managers, engineers, architects, estimators, attorneys, auditors, accountants, purchasing and contracting agents, expeditors, timekeepers, clerks, and other personnel employed by Contractor, whether at the Site or in Contractor's principal or branch office for general administration of the Work and not specifically included in the agreed upon schedule of job classifications referred to in Paragraph 11.01.A.1 or specifically covered by Paragraph 11.01.A.4, all of which are to be considered administrative costs covered by the Contractor's fee.
2. Expenses of Contractor's principal and branch offices other than Contractor's office at the Site.
3. Any part of Contractor's capital expenses, including interest on Contractor's capital employed for the Work and charges against Contractor for delinquent payments.
4. Costs due to the negligence of Contractor, any Subcontractor, or anyone directly or indirectly employed by any of them or for whose acts any of them may be liable, including but not

limited to, the correction of defective Work, disposal of materials or equipment wrongly supplied, and making good any damage to property.

5. Other overhead or general expense costs of any kind and the costs of any item not specifically and expressly included in Paragraphs 11.01.A.
- C. *Contractor's Fee:* When all the Work is performed on the basis of cost-plus, Contractor's fee shall be determined as set forth in the Agreement. When the value of any Work covered by a Change Order or when a Claim for an adjustment in Contract Price is determined on the basis of Cost of the Work, Contractor's fee shall be determined as set forth in Paragraph 12.01.C.
- D. *Documentation:* Whenever the Cost of the Work for any purpose is to be determined pursuant to Paragraphs 11.01.A and 11.01.B, Contractor will establish and maintain records thereof in accordance with generally accepted accounting practices and submit in a form acceptable to Engineer an itemized cost breakdown together with supporting data.

#### 11.02 *Allowances*

- A. It is understood that Contractor has included in the Contract Price all allowances so named in the Contract Documents and shall cause the Work so covered to be performed for such sums and by such persons or entities as may be acceptable to Owner and Engineer.
- B. *Cash Allowances:*
  1. Contractor agrees that:
    - a. the cash allowances include the cost to Contractor (less any applicable trade discounts) of materials and equipment required by the allowances to be delivered at the Site, and all applicable taxes; and
    - b. Contractor's costs for unloading and handling on the Site, labor, installation, overhead, profit, and other expenses contemplated for the cash allowances have been included in the Contract Price and not in the allowances, and no demand for additional payment on account of any of the foregoing will be valid.

#### C. *Contingency Allowance:*

1. Contractor agrees that a contingency allowance, if any, is for the sole use of Owner to cover unanticipated costs.
- D. Prior to final payment, an appropriate Change Order will be issued as recommended by Engineer to reflect actual amounts due Contractor on account of Work covered by allowances, and the Contract Price shall be correspondingly adjusted.

#### 11.03 *Unit Price Work*

- A. Where the Contract Documents provide that all or part of the Work is to be Unit Price Work, initially the Contract Price will be deemed to include for all Unit Price Work an amount equal to

the sum of the unit price for each separately identified item of Unit Price Work times the estimated quantity of each item as indicated in the Agreement.

- B. The estimated quantities of items of Unit Price Work are not guaranteed and are solely for the purpose of comparison of Bids and determining an initial Contract Price. Determinations of the actual quantities and classifications of Unit Price Work performed by Contractor will be made by Engineer subject to the provisions of Paragraph 9.07.
- C. Each unit price will be deemed to include an amount considered by Contractor to be adequate to cover Contractor's overhead and profit for each separately identified item.
- D. Owner or Contractor may make a Claim for an adjustment in the Contract Price in accordance with Paragraph 10.05 if:
  - 1. the quantity of any item of Unit Price Work performed by Contractor differs materially and significantly from the estimated quantity of such item indicated in the Agreement; and
  - 2. there is no corresponding adjustment with respect to any other item of Work; and
  - 3. Contractor believes that Contractor is entitled to an increase in Contract Price as a result of having incurred additional expense or Owner believes that Owner is entitled to a decrease in Contract Price and the parties are unable to agree as to the amount of any such increase or decrease.

## **ARTICLE 12 – CHANGE OF CONTRACT PRICE; CHANGE OF CONTRACT TIMES**

### **12.01 *Change of Contract Price***

- A. The Contract Price may only be changed by a Change Order. Any Claim for an adjustment in the Contract Price shall be based on written notice submitted by the party making the Claim to the Engineer and the other party to the Contract in accordance with the provisions of Paragraph 10.05.
- B. The value of any Work covered by a Change Order or of any Claim for an adjustment in the Contract Price will be determined as follows:
  - 1. where the Work involved is covered by unit prices contained in the Contract Documents, by application of such unit prices to the quantities of the items involved (subject to the provisions of Paragraph 11.03); or
  - 2. where the Work involved is not covered by unit prices contained in the Contract Documents, by a mutually agreed lump sum (which may include an allowance for overhead and profit not necessarily in accordance with Paragraph 12.01.C.2); or
  - 3. where the Work involved is not covered by unit prices contained in the Contract Documents and agreement to a lump sum is not reached under Paragraph 12.01.B.2, on the basis of the Cost of the Work (determined as provided in Paragraph 11.01) plus a Contractor's fee for overhead and profit (determined as provided in Paragraph 12.01.C).

C. *Contractor's Fee*: The Contractor's fee for overhead and profit shall be determined as follows:

1. a mutually acceptable fixed fee; or
2. if a fixed fee is not agreed upon, then a fee based on the following percentages of the various portions of the Cost of the Work:
  - a. for costs incurred under Paragraphs 11.01.A.1 and 11.01.A.2, the Contractor's fee shall be 15 percent;
  - b. for costs incurred under Paragraph 11.01.A.3, the Contractor's fee shall be five percent;
  - c. where one or more tiers of subcontracts are on the basis of Cost of the Work plus a fee and no fixed fee is agreed upon, the intent of Paragraphs 12.01.C.2.a and 12.01.C.2.b is that the Subcontractor who actually performs the Work, at whatever tier, will be paid a fee of 15 percent of the costs incurred by such Subcontractor under Paragraphs 11.01.A.1 and 11.01.A.2 and that any higher tier Subcontractor and Contractor will each be paid a fee of five percent of the amount paid to the next lower tier Subcontractor;
  - d. no fee shall be payable on the basis of costs itemized under Paragraphs 11.01.A.4, 11.01.A.5, and 11.01.B;
  - e. the amount of credit to be allowed by Contractor to Owner for any change which results in a net decrease in cost will be the amount of the actual net decrease in cost plus a deduction in Contractor's fee by an amount equal to five percent of such net decrease; and
  - f. when both additions and credits are involved in any one change, the adjustment in Contractor's fee shall be computed on the basis of the net change in accordance with Paragraphs 12.01.C.2.a through 12.01.C.2.e, inclusive.

#### 12.02 *Change of Contract Times*

- A. The Contract Times may only be changed by a Change Order. Any Claim for an adjustment in the Contract Times shall be based on written notice submitted by the party making the Claim to the Engineer and the other party to the Contract in accordance with the provisions of Paragraph 10.05.
- B. Any adjustment of the Contract Times covered by a Change Order or any Claim for an adjustment in the Contract Times will be determined in accordance with the provisions of this Article 12.

#### 12.03 *Delays*

- A. Where Contractor is prevented from completing any part of the Work within the Contract Times due to delay beyond the control of Contractor, the Contract Times will be extended in an amount equal to the time lost due to such delay if a Claim is made therefor as provided in Paragraph 12.02.A. Delays beyond the control of Contractor shall include, but not be limited to, acts or

neglect by Owner, acts or neglect of utility owners or other contractors performing other work as contemplated by Article 7, fires, floods, epidemics, abnormal weather conditions, or acts of God.

- B. If Owner, Engineer, or other contractors or utility owners performing other work for Owner as contemplated by Article 7, or anyone for whom Owner is responsible, delays, disrupts, or interferes with the performance or progress of the Work, then Contractor shall be entitled to an equitable adjustment in the Contract Price or the Contract Times, or both. Contractor's entitlement to an adjustment of the Contract Times is conditioned on such adjustment being essential to Contractor's ability to complete the Work within the Contract Times.
- C. If Contractor is delayed in the performance or progress of the Work by fire, flood, epidemic, abnormal weather conditions, acts of God, acts or failures to act of utility owners not under the control of Owner, or other causes not the fault of and beyond control of Owner and Contractor, then Contractor shall be entitled to an equitable adjustment in Contract Times, if such adjustment is essential to Contractor's ability to complete the Work within the Contract Times. Such an adjustment shall be Contractor's sole and exclusive remedy for the delays described in this Paragraph 12.03.C.
- D. Owner, Engineer, and their officers, directors, members, partners, employees, agents, consultants, or subcontractors shall not be liable to Contractor for any claims, costs, losses, or damages (including but not limited to all fees and charges of engineers, architects, attorneys, and other professionals and all court or arbitration or other dispute resolution costs) sustained by Contractor on or in connection with any other project or anticipated project.
- E. Contractor shall not be entitled to an adjustment in Contract Price or Contract Times for delays within the control of Contractor. Delays attributable to and within the control of a Subcontractor or Supplier shall be deemed to be delays within the control of Contractor.

## **ARTICLE 13 – TESTS AND INSPECTIONS; CORRECTION, REMOVAL OR ACCEPTANCE OF DEFECTIVE WORK**

### *13.01 Notice of Defects*

- A. Prompt notice of all defective Work of which Owner or Engineer has actual knowledge will be given to Contractor. Defective Work may be rejected, corrected, or accepted as provided in this Article 13.

### *13.02 Access to Work*

- A. Owner, Engineer, their consultants and other representatives and personnel of Owner, independent testing laboratories, and governmental agencies with jurisdictional interests will have access to the Site and the Work at reasonable times for their observation, inspection, and testing. Contractor shall provide them proper and safe conditions for such access and advise them of Contractor's safety procedures and programs so that they may comply therewith as applicable.

### 13.03 *Tests and Inspections*

- A. Contractor shall give Engineer timely notice of readiness of the Work for all required inspections, tests, or approvals and shall cooperate with inspection and testing personnel to facilitate required inspections or tests.
- B. Owner shall employ and pay for the services of an independent testing laboratory to perform all inspections, tests, or approvals required by the Contract Documents except:
  - 1. for inspections, tests, or approvals covered by Paragraphs 13.03.C and 13.03.D below;
  - 2. that costs incurred in connection with tests or inspections conducted pursuant to Paragraph 13.04.B shall be paid as provided in Paragraph 13.04.C; and
  - 3. as otherwise specifically provided in the Contract Documents.
- C. If Laws or Regulations of any public body having jurisdiction require any Work (or part thereof) specifically to be inspected, tested, or approved by an employee or other representative of such public body, Contractor shall assume full responsibility for arranging and obtaining such inspections, tests, or approvals, pay all costs in connection therewith, and furnish Engineer the required certificates of inspection or approval.
- D. Contractor shall be responsible for arranging and obtaining and shall pay all costs in connection with any inspections, tests, or approvals required for Owner's and Engineer's acceptance of materials or equipment to be incorporated in the Work; or acceptance of materials, mix designs, or equipment submitted for approval prior to Contractor's purchase thereof for incorporation in the Work. Such inspections, tests, or approvals shall be performed by organizations acceptable to Owner and Engineer.
- E. If any Work (or the work of others) that is to be inspected, tested, or approved is covered by Contractor without written concurrence of Engineer, Contractor shall, if requested by Engineer, uncover such Work for observation.
- F. Uncovering Work as provided in Paragraph 13.03.E shall be at Contractor's expense unless Contractor has given Engineer timely notice of Contractor's intention to cover the same and Engineer has not acted with reasonable promptness in response to such notice.

### 13.04 *Uncovering Work*

- A. If any Work is covered contrary to the written request of Engineer, it must, if requested by Engineer, be uncovered for Engineer's observation and replaced at Contractor's expense.
- B. If Engineer considers it necessary or advisable that covered Work be observed by Engineer or inspected or tested by others, Contractor, at Engineer's request, shall uncover, expose, or otherwise make available for observation, inspection, or testing as Engineer may require, that portion of the Work in question, furnishing all necessary labor, material, and equipment.

- C. If it is found that the uncovered Work is defective, Contractor shall pay all claims, costs, losses, and damages (including but not limited to all fees and charges of engineers, architects, attorneys, and other professionals and all court or arbitration or other dispute resolution costs) arising out of or relating to such uncovering, exposure, observation, inspection, and testing, and of satisfactory replacement or reconstruction (including but not limited to all costs of repair or replacement of work of others); and Owner shall be entitled to an appropriate decrease in the Contract Price. If the parties are unable to agree as to the amount thereof, Owner may make a Claim therefor as provided in Paragraph 10.05.
- D. If the uncovered Work is not found to be defective, Contractor shall be allowed an increase in the Contract Price or an extension of the Contract Times, or both, directly attributable to such uncovering, exposure, observation, inspection, testing, replacement, and reconstruction. If the parties are unable to agree as to the amount or extent thereof, Contractor may make a Claim therefor as provided in Paragraph 10.05.

#### 13.05 *Owner May Stop the Work*

- A. If the Work is defective, or Contractor fails to supply sufficient skilled workers or suitable materials or equipment, or fails to perform the Work in such a way that the completed Work will conform to the Contract Documents, Owner may order Contractor to stop the Work, or any portion thereof, until the cause for such order has been eliminated; however, this right of Owner to stop the Work shall not give rise to any duty on the part of Owner to exercise this right for the benefit of Contractor, any Subcontractor, any Supplier, any other individual or entity, or any surety for, or employee or agent of any of them.

#### 13.06 *Correction or Removal of Defective Work*

- A. Promptly after receipt of written notice, Contractor shall correct all defective Work, whether or not fabricated, installed, or completed, or, if the Work has been rejected by Engineer, remove it from the Project and replace it with Work that is not defective. Contractor shall pay all claims, costs, losses, and damages (including but not limited to all fees and charges of engineers, architects, attorneys, and other professionals and all court or arbitration or other dispute resolution costs) arising out of or relating to such correction or removal (including but not limited to all costs of repair or replacement of work of others).
- B. When correcting defective Work under the terms of this Paragraph 13.06 or Paragraph 13.07, Contractor shall take no action that would void or otherwise impair Owner's special warranty and guarantee, if any, on said Work.

#### 13.07 *Correction Period*

- A. If within one year after the date of Substantial Completion (or such longer period of time as may be prescribed by the terms of any applicable special guarantee required by the Contract Documents) or by any specific provision of the Contract Documents, any Work is found to be defective, or if the repair of any damages to the land or areas made available for Contractor's use by Owner or permitted by Laws and Regulations as contemplated in Paragraph 6.11.A is found to be defective, Contractor shall promptly, without cost to Owner and in accordance with Owner's written instructions:



1. repair such defective land or areas; or
  2. correct such defective Work; or
  3. if the defective Work has been rejected by Owner, remove it from the Project and replace it with Work that is not defective, and
  4. satisfactorily correct or repair or remove and replace any damage to other Work, to the work of others or other land or areas resulting therefrom.
- B. If Contractor does not promptly comply with the terms of Owner's written instructions, or in an emergency where delay would cause serious risk of loss or damage, Owner may have the defective Work corrected or repaired or may have the rejected Work removed and replaced. All claims, costs, losses, and damages (including but not limited to all fees and charges of engineers, architects, attorneys, and other professionals and all court or arbitration or other dispute resolution costs) arising out of or relating to such correction or repair or such removal and replacement (including but not limited to all costs of repair or replacement of work of others) will be paid by Contractor.
- C. In special circumstances where a particular item of equipment is placed in continuous service before Substantial Completion of all the Work, the correction period for that item may start to run from an earlier date if so provided in the Specifications.
- D. Where defective Work (and damage to other Work resulting therefrom) has been corrected or removed and replaced under this Paragraph 13.07, the correction period hereunder with respect to such Work will be extended for an additional period of one year after such correction or removal and replacement has been satisfactorily completed.
- E. Contractor's obligations under this Paragraph 13.07 are in addition to any other obligation or warranty. The provisions of this Paragraph 13.07 shall not be construed as a substitute for, or a waiver of, the provisions of any applicable statute of limitation or repose.

#### 13.08 *Acceptance of Defective Work*

- A. If, instead of requiring correction or removal and replacement of defective Work, Owner (and, prior to Engineer's recommendation of final payment, Engineer) prefers to accept it, Owner may do so. Contractor shall pay all claims, costs, losses, and damages (including but not limited to all fees and charges of engineers, architects, attorneys, and other professionals and all court or arbitration or other dispute resolution costs) attributable to Owner's evaluation of and determination to accept such defective Work (such costs to be approved by Engineer as to reasonableness) and for the diminished value of the Work to the extent not otherwise paid by Contractor pursuant to this sentence. If any such acceptance occurs prior to Engineer's recommendation of final payment, a Change Order will be issued incorporating the necessary revisions in the Contract Documents with respect to the Work, and Owner shall be entitled to an appropriate decrease in the Contract Price, reflecting the diminished value of Work so accepted. If the parties are unable to agree as to the amount thereof, Owner may make a Claim therefor as provided in Paragraph 10.05. If the acceptance occurs after such recommendation, an appropriate amount will be paid by Contractor to Owner.

### 13.09 *Owner May Correct Defective Work*

- A. If Contractor fails within a reasonable time after written notice from Engineer to correct defective Work, or to remove and replace rejected Work as required by Engineer in accordance with Paragraph 13.06.A, or if Contractor fails to perform the Work in accordance with the Contract Documents, or if Contractor fails to comply with any other provision of the Contract Documents, Owner may, after seven days written notice to Contractor, correct, or remedy any such deficiency.
- B. In exercising the rights and remedies under this Paragraph 13.09, Owner shall proceed expeditiously. In connection with such corrective or remedial action, Owner may exclude Contractor from all or part of the Site, take possession of all or part of the Work and suspend Contractor's services related thereto, take possession of Contractor's tools, appliances, construction equipment and machinery at the Site, and incorporate in the Work all materials and equipment stored at the Site or for which Owner has paid Contractor but which are stored elsewhere. Contractor shall allow Owner, Owner's representatives, agents and employees, Owner's other contractors, and Engineer and Engineer's consultants access to the Site to enable Owner to exercise the rights and remedies under this Paragraph.
- C. All claims, costs, losses, and damages (including but not limited to all fees and charges of engineers, architects, attorneys, and other professionals and all court or arbitration or other dispute resolution costs) incurred or sustained by Owner in exercising the rights and remedies under this Paragraph 13.09 will be charged against Contractor, and a Change Order will be issued incorporating the necessary revisions in the Contract Documents with respect to the Work; and Owner shall be entitled to an appropriate decrease in the Contract Price. If the parties are unable to agree as to the amount of the adjustment, Owner may make a Claim therefor as provided in Paragraph 10.05. Such claims, costs, losses and damages will include but not be limited to all costs of repair, or replacement of work of others destroyed or damaged by correction, removal, or replacement of Contractor's defective Work.
- D. Contractor shall not be allowed an extension of the Contract Times because of any delay in the performance of the Work attributable to the exercise by Owner of Owner's rights and remedies under this Paragraph 13.09.

## **ARTICLE 14 – PAYMENTS TO CONTRACTOR AND COMPLETION**

### 14.01 *Schedule of Values*

- A. The Schedule of Values established as provided in Paragraph 2.07.A will serve as the basis for progress payments and will be incorporated into a form of Application for Payment acceptable to Engineer. Progress payments on account of Unit Price Work will be based on the number of units completed.

### 14.02 *Progress Payments*

#### *A. Applications for Payments:*

- 1. At least 20 days before the date established in the Agreement for each progress payment (but not more often than once a month), Contractor shall submit to Engineer for review an

Application for Payment filled out and signed by Contractor covering the Work completed as of the date of the Application and accompanied by such supporting documentation as is required by the Contract Documents. If payment is requested on the basis of materials and equipment not incorporated in the Work but delivered and suitably stored at the Site or at another location agreed to in writing, the Application for Payment shall also be accompanied by a bill of sale, invoice, or other documentation warranting that Owner has received the materials and equipment free and clear of all Liens and evidence that the materials and equipment are covered by appropriate property insurance or other arrangements to protect Owner's interest therein, all of which must be satisfactory to Owner.

2. Beginning with the second Application for Payment, each Application shall include an affidavit of Contractor stating that all previous progress payments received on account of the Work have been applied on account to discharge Contractor's legitimate obligations associated with prior Applications for Payment.
3. The amount of retainage with respect to progress payments will be as stipulated in the Agreement.

B. *Review of Applications:*

1. Engineer will, within 10 days after receipt of each Application for Payment, either indicate in writing a recommendation of payment and present the Application to Owner or return the Application to Contractor indicating in writing Engineer's reasons for refusing to recommend payment. In the latter case, Contractor may make the necessary corrections and resubmit the Application.
2. Engineer's recommendation of any payment requested in an Application for Payment will constitute a representation by Engineer to Owner, based on Engineer's observations of the executed Work as an experienced and qualified design professional, and on Engineer's review of the Application for Payment and the accompanying data and schedules, that to the best of Engineer's knowledge, information and belief:
  - a. the Work has progressed to the point indicated;
  - b. the quality of the Work is generally in accordance with the Contract Documents (subject to an evaluation of the Work as a functioning whole prior to or upon Substantial Completion, the results of any subsequent tests called for in the Contract Documents, a final determination of quantities and classifications for Unit Price Work under Paragraph 9.07, and any other qualifications stated in the recommendation); and
  - c. the conditions precedent to Contractor's being entitled to such payment appear to have been fulfilled in so far as it is Engineer's responsibility to observe the Work.
3. By recommending any such payment Engineer will not thereby be deemed to have represented that:
  - a. inspections made to check the quality or the quantity of the Work as it has been performed have been exhaustive, extended to every aspect of the Work in progress, or

involved detailed inspections of the Work beyond the responsibilities specifically assigned to Engineer in the Contract Documents; or

- b. there may not be other matters or issues between the parties that might entitle Contractor to be paid additionally by Owner or entitle Owner to withhold payment to Contractor.
4. Neither Engineer's review of Contractor's Work for the purposes of recommending payments nor Engineer's recommendation of any payment, including final payment, will impose responsibility on Engineer:
    - a. to supervise, direct, or control the Work, or
    - b. for the means, methods, techniques, sequences, or procedures of construction, or the safety precautions and programs incident thereto, or
    - c. for Contractor's failure to comply with Laws and Regulations applicable to Contractor's performance of the Work, or
    - d. to make any examination to ascertain how or for what purposes Contractor has used the moneys paid on account of the Contract Price, or
    - e. to determine that title to any of the Work, materials, or equipment has passed to Owner free and clear of any Liens.
  5. Engineer may refuse to recommend the whole or any part of any payment if, in Engineer's opinion, it would be incorrect to make the representations to Owner stated in Paragraph 14.02.B.2. Engineer may also refuse to recommend any such payment or, because of subsequently discovered evidence or the results of subsequent inspections or tests, revise or revoke any such payment recommendation previously made, to such extent as may be necessary in Engineer's opinion to protect Owner from loss because:
    - a. the Work is defective, or completed Work has been damaged, requiring correction or replacement;
    - b. the Contract Price has been reduced by Change Orders;
    - c. Owner has been required to correct defective Work or complete Work in accordance with Paragraph 13.09; or
    - d. Engineer has actual knowledge of the occurrence of any of the events enumerated in Paragraph 15.02.A.

*C. Payment Becomes Due:*

1. Ten days after presentation of the Application for Payment to Owner with Engineer's recommendation, the amount recommended will (subject to the provisions of Paragraph 14.02.D) become due, and when due will be paid by Owner to Contractor.

D. *Reduction in Payment:*

1. Owner may refuse to make payment of the full amount recommended by Engineer because:
  - a. claims have been made against Owner on account of Contractor's performance or furnishing of the Work;
  - b. Liens have been filed in connection with the Work, except where Contractor has delivered a specific bond satisfactory to Owner to secure the satisfaction and discharge of such Liens;
  - c. there are other items entitling Owner to a set-off against the amount recommended; or
  - d. Owner has actual knowledge of the occurrence of any of the events enumerated in Paragraphs 14.02.B.5.a through 14.02.B.5.c or Paragraph 15.02.A.
2. If Owner refuses to make payment of the full amount recommended by Engineer, Owner will give Contractor immediate written notice (with a copy to Engineer) stating the reasons for such action and promptly pay Contractor any amount remaining after deduction of the amount so withheld. Owner shall promptly pay Contractor the amount so withheld, or any adjustment thereto agreed to by Owner and Contractor, when Contractor remedies the reasons for such action.
3. Upon a subsequent determination that Owner's refusal of payment was not justified, the amount wrongfully withheld shall be treated as an amount due as determined by Paragraph 14.02.C.1 and subject to interest as provided in the Agreement.

14.03 *Contractor's Warranty of Title*

- A. Contractor warrants and guarantees that title to all Work, materials, and equipment covered by any Application for Payment, whether incorporated in the Project or not, will pass to Owner no later than the time of payment free and clear of all Liens.

14.04 *Substantial Completion*

- A. When Contractor considers the entire Work ready for its intended use Contractor shall notify Owner and Engineer in writing that the entire Work is substantially complete (except for items specifically listed by Contractor as incomplete) and request that Engineer issue a certificate of Substantial Completion.
- B. Promptly after Contractor's notification, Owner, Contractor, and Engineer shall make an inspection of the Work to determine the status of completion. If Engineer does not consider the Work substantially complete, Engineer will notify Contractor in writing giving the reasons therefor.
- C. If Engineer considers the Work substantially complete, Engineer will deliver to Owner a tentative certificate of Substantial Completion which shall fix the date of Substantial Completion. There shall be attached to the certificate a tentative list of items to be completed or corrected before

final payment. Owner shall have seven days after receipt of the tentative certificate during which to make written objection to Engineer as to any provisions of the certificate or attached list. If, after considering such objections, Engineer concludes that the Work is not substantially complete, Engineer will, within 14 days after submission of the tentative certificate to Owner, notify Contractor in writing, stating the reasons therefor. If, after consideration of Owner's objections, Engineer considers the Work substantially complete, Engineer will, within said 14 days, execute and deliver to Owner and Contractor a definitive certificate of Substantial Completion (with a revised tentative list of items to be completed or corrected) reflecting such changes from the tentative certificate as Engineer believes justified after consideration of any objections from Owner.

- D. At the time of delivery of the tentative certificate of Substantial Completion, Engineer will deliver to Owner and Contractor a written recommendation as to division of responsibilities pending final payment between Owner and Contractor with respect to security, operation, safety, and protection of the Work, maintenance, heat, utilities, insurance, and warranties and guarantees. Unless Owner and Contractor agree otherwise in writing and so inform Engineer in writing prior to Engineer's issuing the definitive certificate of Substantial Completion, Engineer's aforesaid recommendation will be binding on Owner and Contractor until final payment.
- E. Owner shall have the right to exclude Contractor from the Site after the date of Substantial Completion subject to allowing Contractor reasonable access to remove its property and complete or correct items on the tentative list.

#### 14.05 *Partial Utilization*

- A. Prior to Substantial Completion of all the Work, Owner may use or occupy any substantially completed part of the Work which has specifically been identified in the Contract Documents, or which Owner, Engineer, and Contractor agree constitutes a separately functioning and usable part of the Work that can be used by Owner for its intended purpose without significant interference with Contractor's performance of the remainder of the Work, subject to the following conditions:
  - 1. Owner at any time may request Contractor in writing to permit Owner to use or occupy any such part of the Work which Owner believes to be ready for its intended use and substantially complete. If and when Contractor agrees that such part of the Work is substantially complete, Contractor, Owner, and Engineer will follow the procedures of Paragraph 14.04.A through D for that part of the Work.
  - 2. Contractor at any time may notify Owner and Engineer in writing that Contractor considers any such part of the Work ready for its intended use and substantially complete and request Engineer to issue a certificate of Substantial Completion for that part of the Work.
  - 3. Within a reasonable time after either such request, Owner, Contractor, and Engineer shall make an inspection of that part of the Work to determine its status of completion. If Engineer does not consider that part of the Work to be substantially complete, Engineer will notify Owner and Contractor in writing giving the reasons therefor. If Engineer considers that part of the Work to be substantially complete, the provisions of Paragraph 14.04 will apply with respect to certification of Substantial Completion of that part of the Work and the division of responsibility in respect thereof and access thereto.

4. No use or occupancy or separate operation of part of the Work may occur prior to compliance with the requirements of Paragraph 5.10 regarding property insurance.

#### 14.06 *Final Inspection*

- A. Upon written notice from Contractor that the entire Work or an agreed portion thereof is complete, Engineer will promptly make a final inspection with Owner and Contractor and will notify Contractor in writing of all particulars in which this inspection reveals that the Work is incomplete or defective. Contractor shall immediately take such measures as are necessary to complete such Work or remedy such deficiencies.

#### 14.07 *Final Payment*

##### A. *Application for Payment:*

1. After Contractor has, in the opinion of Engineer, satisfactorily completed all corrections identified during the final inspection and has delivered, in accordance with the Contract Documents, all maintenance and operating instructions, schedules, guarantees, bonds, certificates or other evidence of insurance, certificates of inspection, marked-up record documents (as provided in Paragraph 6.12), and other documents, Contractor may make application for final payment following the procedure for progress payments.
2. The final Application for Payment shall be accompanied (except as previously delivered) by:
  - a. all documentation called for in the Contract Documents, including but not limited to the evidence of insurance required by Paragraph 5.04.B.6;
  - b. consent of the surety, if any, to final payment;
  - c. a list of all Claims against Owner that Contractor believes are unsettled; and
  - d. complete and legally effective releases or waivers (satisfactory to Owner) of all Lien rights arising out of or Liens filed in connection with the Work.
3. In lieu of the releases or waivers of Liens specified in Paragraph 14.07.A.2 and as approved by Owner, Contractor may furnish receipts or releases in full and an affidavit of Contractor that: (i) the releases and receipts include all labor, services, material, and equipment for which a Lien could be filed; and (ii) all payrolls, material and equipment bills, and other indebtedness connected with the Work for which Owner might in any way be responsible, or which might in any way result in liens or other burdens on Owner's property, have been paid or otherwise satisfied. If any Subcontractor or Supplier fails to furnish such a release or receipt in full, Contractor may furnish a bond or other collateral satisfactory to Owner to indemnify Owner against any Lien.

##### B. *Engineer's Review of Application and Acceptance:*

1. If, on the basis of Engineer's observation of the Work during construction and final inspection, and Engineer's review of the final Application for Payment and accompanying

documentation as required by the Contract Documents, Engineer is satisfied that the Work has been completed and Contractor's other obligations under the Contract Documents have been fulfilled, Engineer will, within ten days after receipt of the final Application for Payment, indicate in writing Engineer's recommendation of payment and present the Application for Payment to Owner for payment. At the same time Engineer will also give written notice to Owner and Contractor that the Work is acceptable subject to the provisions of Paragraph 14.09. Otherwise, Engineer will return the Application for Payment to Contractor, indicating in writing the reasons for refusing to recommend final payment, in which case Contractor shall make the necessary corrections and resubmit the Application for Payment.

C. *Payment Becomes Due:*

1. Thirty days after the presentation to Owner of the Application for Payment and accompanying documentation, the amount recommended by Engineer, less any sum Owner is entitled to set off against Engineer's recommendation, including but not limited to liquidated damages, will become due and will be paid by Owner to Contractor.

14.08 *Final Completion Delayed*

- A. If, through no fault of Contractor, final completion of the Work is significantly delayed, and if Engineer so confirms, Owner shall, upon receipt of Contractor's final Application for Payment (for Work fully completed and accepted) and recommendation of Engineer, and without terminating the Contract, make payment of the balance due for that portion of the Work fully completed and accepted. If the remaining balance to be held by Owner for Work not fully completed or corrected is less than the retainage stipulated in the Agreement, and if bonds have been furnished as required in Paragraph 5.01, the written consent of the surety to the payment of the balance due for that portion of the Work fully completed and accepted shall be submitted by Contractor to Engineer with the Application for such payment. Such payment shall be made under the terms and conditions governing final payment, except that it shall not constitute a waiver of Claims.

14.09 *Waiver of Claims*

- A. The making and acceptance of final payment will constitute:
  1. a waiver of all Claims by Owner against Contractor, except Claims arising from unsettled Liens, from defective Work appearing after final inspection pursuant to Paragraph 14.06, from failure to comply with the Contract Documents or the terms of any special guarantees specified therein, or from Contractor's continuing obligations under the Contract Documents; and
  2. a waiver of all Claims by Contractor against Owner other than those previously made in accordance with the requirements herein and expressly acknowledged by Owner in writing as still unsettled.



## ARTICLE 15 – SUSPENSION OF WORK AND TERMINATION

### 15.01 *Owner May Suspend Work*

- A. At any time and without cause, Owner may suspend the Work or any portion thereof for a period of not more than 90 consecutive days by notice in writing to Contractor and Engineer which will fix the date on which Work will be resumed. Contractor shall resume the Work on the date so fixed. Contractor shall be granted an adjustment in the Contract Price or an extension of the Contract Times, or both, directly attributable to any such suspension if Contractor makes a Claim therefor as provided in Paragraph 10.05.

### 15.02 *Owner May Terminate for Cause*

- A. The occurrence of any one or more of the following events will justify termination for cause:
  1. Contractor's persistent failure to perform the Work in accordance with the Contract Documents (including, but not limited to, failure to supply sufficient skilled workers or suitable materials or equipment or failure to adhere to the Progress Schedule established under Paragraph 2.07 as adjusted from time to time pursuant to Paragraph 6.04);
  2. Contractor's disregard of Laws or Regulations of any public body having jurisdiction;
  3. Contractor's repeated disregard of the authority of Engineer; or
  4. Contractor's violation in any substantial way of any provisions of the Contract Documents.
- B. If one or more of the events identified in Paragraph 15.02.A occur, Owner may, after giving Contractor (and surety) seven days written notice of its intent to terminate the services of Contractor:
  1. exclude Contractor from the Site, and take possession of the Work and of all Contractor's tools, appliances, construction equipment, and machinery at the Site, and use the same to the full extent they could be used by Contractor (without liability to Contractor for trespass or conversion);
  2. incorporate in the Work all materials and equipment stored at the Site or for which Owner has paid Contractor but which are stored elsewhere; and
  3. complete the Work as Owner may deem expedient.
- C. If Owner proceeds as provided in Paragraph 15.02.B, Contractor shall not be entitled to receive any further payment until the Work is completed. If the unpaid balance of the Contract Price exceeds all claims, costs, losses, and damages (including but not limited to all fees and charges of engineers, architects, attorneys, and other professionals and all court or arbitration or other dispute resolution costs) sustained by Owner arising out of or relating to completing the Work, such excess will be paid to Contractor. If such claims, costs, losses, and damages exceed such unpaid balance, Contractor shall pay the difference to Owner. Such claims, costs, losses, and damages incurred by Owner will be reviewed by Engineer as to their reasonableness and, when

so approved by Engineer, incorporated in a Change Order. When exercising any rights or remedies under this Paragraph, Owner shall not be required to obtain the lowest price for the Work performed.

- D. Notwithstanding Paragraphs 15.02.B and 15.02.C, Contractor's services will not be terminated if Contractor begins within seven days of receipt of notice of intent to terminate to correct its failure to perform and proceeds diligently to cure such failure within no more than 30 days of receipt of said notice.
- E. Where Contractor's services have been so terminated by Owner, the termination will not affect any rights or remedies of Owner against Contractor then existing or which may thereafter accrue. Any retention or payment of moneys due Contractor by Owner will not release Contractor from liability.
- F. If and to the extent that Contractor has provided a performance bond under the provisions of Paragraph 5.01.A, the termination procedures of that bond shall supersede the provisions of Paragraphs 15.02.B and 15.02.C.

#### 15.03 *Owner May Terminate For Convenience*

- A. Upon seven days written notice to Contractor and Engineer, Owner may, without cause and without prejudice to any other right or remedy of Owner, terminate the Contract. In such case, Contractor shall be paid for (without duplication of any items):
  - 1. completed and acceptable Work executed in accordance with the Contract Documents prior to the effective date of termination, including fair and reasonable sums for overhead and profit on such Work;
  - 2. expenses sustained prior to the effective date of termination in performing services and furnishing labor, materials, or equipment as required by the Contract Documents in connection with uncompleted Work, plus fair and reasonable sums for overhead and profit on such expenses;
  - 3. all claims, costs, losses, and damages (including but not limited to all fees and charges of engineers, architects, attorneys, and other professionals and all court or arbitration or other dispute resolution costs) incurred in settlement of terminated contracts with Subcontractors, Suppliers, and others; and
  - 4. reasonable expenses directly attributable to termination.
- B. Contractor shall not be paid on account of loss of anticipated profits or revenue or other economic loss arising out of or resulting from such termination.

#### 15.04 *Contractor May Stop Work or Terminate*

- A. If, through no act or fault of Contractor, (i) the Work is suspended for more than 90 consecutive days by Owner or under an order of court or other public authority, or (ii) Engineer fails to act on any Application for Payment within 30 days after it is submitted, or (iii) Owner fails for 30 days

to pay Contractor any sum finally determined to be due, then Contractor may, upon seven days written notice to Owner and Engineer, and provided Owner or Engineer do not remedy such suspension or failure within that time, terminate the Contract and recover from Owner payment on the same terms as provided in Paragraph 15.03.

- B. In lieu of terminating the Contract and without prejudice to any other right or remedy, if Engineer has failed to act on an Application for Payment within 30 days after it is submitted, or Owner has failed for 30 days to pay Contractor any sum finally determined to be due, Contractor may, seven days after written notice to Owner and Engineer, stop the Work until payment is made of all such amounts due Contractor, including interest thereon. The provisions of this Paragraph 15.04 are not intended to preclude Contractor from making a Claim under Paragraph 10.05 for an adjustment in Contract Price or Contract Times or otherwise for expenses or damage directly attributable to Contractor's stopping the Work as permitted by this Paragraph.

## **ARTICLE 16 – DISPUTE RESOLUTION**

### *16.01 Methods and Procedures*

- A. Either Owner or Contractor may request mediation of any Claim submitted to Engineer for a decision under Paragraph 10.05 before such decision becomes final and binding. The mediation will be governed by the Construction Industry Mediation Rules of the American Arbitration Association in effect as of the Effective Date of the Agreement. The request for mediation shall be submitted in writing to the American Arbitration Association and the other party to the Contract. Timely submission of the request shall stay the effect of Paragraph 10.05.E.
- B. Owner and Contractor shall participate in the mediation process in good faith. The process shall be concluded within 60 days of filing of the request. The date of termination of the mediation shall be determined by application of the mediation rules referenced above.
- C. If the Claim is not resolved by mediation, Engineer's action under Paragraph 10.05.C or a denial pursuant to Paragraphs 10.05.C.3 or 10.05.D shall become final and binding 30 days after termination of the mediation unless, within that time period, Owner or Contractor:
1. elects in writing to invoke any dispute resolution process provided for in the Supplementary Conditions; or
  2. agrees with the other party to submit the Claim to another dispute resolution process; or
  3. gives written notice to the other party of the intent to submit the Claim to a court of competent jurisdiction.

## **ARTICLE 17 – MISCELLANEOUS**

### *17.01 Giving Notice*

- A. Whenever any provision of the Contract Documents requires the giving of written notice, it will be deemed to have been validly given if:

1. delivered in person to the individual or to a member of the firm or to an officer of the corporation for whom it is intended; or
2. delivered at or sent by registered or certified mail, postage prepaid, to the last business address known to the giver of the notice.

17.02 *Computation of Times*

- A. When any period of time is referred to in the Contract Documents by days, it will be computed to exclude the first and include the last day of such period. If the last day of any such period falls on a Saturday or Sunday or on a day made a legal holiday by the law of the applicable jurisdiction, such day will be omitted from the computation.

17.03 *Cumulative Remedies*

- A. The duties and obligations imposed by these General Conditions and the rights and remedies available hereunder to the parties hereto are in addition to, and are not to be construed in any way as a limitation of, any rights and remedies available to any or all of them which are otherwise imposed or available by Laws or Regulations, by special warranty or guarantee, or by other provisions of the Contract Documents. The provisions of this Paragraph will be as effective as if repeated specifically in the Contract Documents in connection with each particular duty, obligation, right, and remedy to which they apply.

17.04 *Survival of Obligations*

- A. All representations, indemnifications, warranties, and guarantees made in, required by, or given in accordance with the Contract Documents, as well as all continuing obligations indicated in the Contract Documents, will survive final payment, completion, and acceptance of the Work or termination or completion of the Contract or termination of the services of Contractor.

17.05 *Controlling Law*

- A. This Contract is to be governed by the law of the state in which the Project is located.

17.06 *Headings*

- A. Article and paragraph headings are inserted for convenience only and do not constitute parts of these General Conditions.

## SUPPLEMENTAL CONDITIONS

### 01. GENERAL CONDITIONS:

The "Standard General Conditions of the Construction Contract", Engineers Joint Contract Documents Committee, 2007 Edition, Articles 1 through 17 inclusive, included herein preceding these supplements, is a part of this Contract.

### ARTICLE 5 - BONDS & INSURANCE

#### 5.04 B 1& 2 Contractor's protective liability insurance, with minimum limits as follows:

General Liability – \$1,000,000 per occurrence;

Damage to rented premises – \$100,000 per occurrence;

Personal injury including death – \$1,000,000 for each occurrence;

General aggregate – \$2,000,000 per project;

Property damage - \$100,000 for each and \$200,000. for the aggregate for operations.

Contractor's automobile liability insurance (including contractual liability insurance as applicable to the Contractor's obligations under paragraph 6.20) with minimum limits as follows:

Automobile liability – \$1,000,000 per occurrence;

Workers compensation – Statutory coverage and \$1,000,000 Employers liability limit.

- (a) Any exclusion of so-called underground damage to pipes, collapse of structures or damage resulting from explosion or blasting, shall be deleted.
- (b) The policy shall provide completed operations coverage, and such coverage shall be maintained by the Contractor for a period of one year from the date of payment of the final amounts owed the Contractor by the Owner, whichever occurs first.

ARTICLE 14 - PAYMENTS TO CONTRACTOR AND COMPLETION

14.02 *Progress Payments*

A. Applications for Payments

1. Add a sentence after the second sentence stating, "Each payment request shall be accompanied with record drawings showing as-built conditions of all work requested during the pay period."

ARTICLE 16 - DISPUTE RESOLUTION

- 16.01 Any dispute arising under this agreement shall first be resolved by utilizing non-binding mediation, however should the dispute not be resolved by this method it shall be heard in the Superior Court of the County in which the owner resides, and the parties consent to jurisdiction and venue in that Court. The parties waive any defense they may have to lack of jurisdiction or improper venue and agree to have all disputes resolved in the Superior Court of the County in which the owner resides.

Not for Bid

"General Decision Number: GA20210163 04/23/2021

Superseded General Decision Number: GA20200163

State: Georgia

Construction Type: Building

Counties: Liberty and Long Counties in Georgia.

Note: Under Executive Order (EO) 13658, an hourly minimum wage of \$10.95 for calendar year 2021 applies to all contracts subject to the Davis-Bacon Act for which the contract is awarded (and any solicitation was issued) on or after January 1, 2015. If this contract is covered by the EO, the contractor must pay all workers in any classification listed on this wage determination at least \$10.95 per hour (or the applicable wage rate listed on this wage determination, if it is higher) for all hours spent performing on the contract in calendar year 2021. If this contract is covered by the EO and a classification considered necessary for performance of work on the contract does not appear on this wage determination, the contractor must pay workers in that classification at least the wage rate determined through the conformance process set forth in 29 CFR 5.5(a)(1)(ii) (or the EO minimum wage rate, if it is higher than the conformed wage rate). The EO minimum wage rate will be adjusted annually. Please note that this EO applies to the above-mentioned types of contracts entered into by the federal government that are subject to the Davis-Bacon Act itself, but it does not apply to contracts subject only to the Davis-Bacon Related Acts, including those set forth at 29 CFR 5.1(a)(2)-(60). Additional information on contractor requirements and worker protections under the EO is available at [www.dol.gov/whd/govcontracts](http://www.dol.gov/whd/govcontracts).

Modification Number	Publication Date
0	01/01/2021
1	04/23/2021

BOIL0026-001 03/01/2018

	Rates	Fringes
BOILERMAKER.....	\$ 28.97	22.39

-----  
 ENGI0474-002 07/01/2020

	Rates	Fringes
POWER EQUIPMENT OPERATOR: Bobcat/Skid Steer/Skid Loader, Bulldozer, Forklift (under 15 tons), and Loader.....	\$ 27.17	15.65
Crane (over 10 tons) and Forklift (15 tons and over).	\$ 29.00	15.65
Crane (over 120 tons).....	\$ 30.00	15.65
Crane (over 250 tons).....	\$ 31.00	15.65
Oiler.....	\$ 24.88	15.65

-----  
 \* PLUM0188-001 11/16/2020

	Rates	Fringes
--	-------	---------

PIPEFITTER.....	\$ 28.65	16.35
PLUMBER (Including HVAC Pipe Installation).....	\$ 28.65	16.35

-----  
SUGA2012-082 08/11/2012

	Rates	Fringes
BRICKLAYER.....	\$ 16.00	0.00
CARPENTER.....	\$ 14.86	0.28
CEMENT MASON/CONCRETE FINISHER...	\$ 15.90	2.66
ELECTRICIAN.....	\$ 18.22	2.49
IRONWORKER, REINFORCING.....	\$ 20.48	8.41
IRONWORKER, STRUCTURAL.....	\$ 21.00	0.00
LABORER: Common or General.....	\$ 11.61	0.56
LABORER: Mason Tender - Brick...	\$ 9.00	0.00
LABORER: Pipelayer.....	\$ 12.00	0.23
OPERATOR: Backhoe/Excavator.....	\$ 11.70	0.00
OPERATOR: Grader/Blade.....	\$ 17.52	0.00
PAINTER: Brush, Roller and Spray.....	\$ 15.32	5.40
ROOFER.....	\$ 11.38	0.00
SHEET METAL WORKER, Includes HVAC Duct Installation.....	\$ 24.64	9.46
TILE FINISHER.....	\$ 10.31	0.00
TILE SETTER.....	\$ 14.00	0.54
TRUCK DRIVER: Dump Truck.....	\$ 13.61	0.00
TRUCK DRIVER: Lowboy Truck.....	\$ 17.41	0.00

-----  
WELDERS - Receive rate prescribed for craft performing  
operation to which welding is incidental.

=====  
Note: Executive Order (EO) 13706, Establishing Paid Sick Leave for Federal Contractors applies to all contracts subject to the Davis-Bacon Act for which the contract is awarded (and any solicitation was issued) on or after January 1, 2017. If this contract is covered by the EO, the contractor must provide employees with 1 hour of paid sick leave for every 30 hours they work, up to 56 hours of paid sick leave each year. Employees must be permitted to use paid sick leave for their own illness, injury or other health-related needs, including preventive care; to assist a family member (or person who is like family to the employee) who is ill, injured, or has other health-related needs, including preventive care; or for reasons



resulting from, or to assist a family member (or person who is like family to the employee) who is a victim of, domestic violence, sexual assault, or stalking. Additional information on contractor requirements and worker protections under the EO is available at [www.dol.gov/whd/govcontracts](http://www.dol.gov/whd/govcontracts).

Unlisted classifications needed for work not included within the scope of the classifications listed may be added after award only as provided in the labor standards contract clauses (29CFR 5.5 (a) (1) (ii)).

-----

The body of each wage determination lists the classification and wage rates that have been found to be prevailing for the cited type(s) of construction in the area covered by the wage determination. The classifications are listed in alphabetical order of ""identifiers"" that indicate whether the particular rate is a union rate (current union negotiated rate for local), a survey rate (weighted average rate) or a union average rate (weighted union average rate).

#### Union Rate Identifiers

A four letter classification abbreviation identifier enclosed in dotted lines beginning with characters other than ""SU"" or ""UAVG"" denotes that the union classification and rate were prevailing for that classification in the survey. Example: PLUM0198-005 07/01/2014. PLUM is an abbreviation identifier of the union which prevailed in the survey for this classification, which in this example would be Plumbers. 0198 indicates the local union number or district council number where applicable, i.e., Plumbers Local 0198. The next number, 005 in the example, is an internal number used in processing the wage determination. 07/01/2014 is the effective date of the most current negotiated rate, which in this example is July 1, 2014.

Union prevailing wage rates are updated to reflect all rate changes in the collective bargaining agreement (CBA) governing this classification and rate.

#### Survey Rate Identifiers

Classifications listed under the ""SU"" identifier indicate that no one rate prevailed for this classification in the survey and the published rate is derived by computing a weighted average rate based on all the rates reported in the survey for that classification. As this weighted average rate includes all rates reported in the survey, it may include both union and non-union rates. Example: SULA2012-007 5/13/2014. SU indicates the rates are survey rates based on a weighted average calculation of rates and are not majority rates. LA indicates the State of Louisiana. 2012 is the year of survey on which these classifications and rates are based. The next number, 007 in the example, is an internal number used in producing the wage determination. 5/13/2014 indicates the survey completion date for the classifications and rates under that identifier.

Survey wage rates are not updated and remain in effect until a new survey is conducted.

#### Union Average Rate Identifiers

Classification(s) listed under the UAVG identifier indicate that no single majority rate prevailed for those classifications; however, 100% of the data reported for the classifications was union data. EXAMPLE: UAVG-OH-0010 08/29/2014. UAVG indicates that the rate is a weighted union average rate. OH indicates the state. The next number, 0010 in the example, is an internal number used in producing the wage determination. 08/29/2014 indicates the survey completion date for the classifications and rates under that identifier.

A UAVG rate will be updated once a year, usually in January of each year, to reflect a weighted average of the current negotiated/CBA rate of the union locals from which the rate is based.

-----  
WAGE DETERMINATION APPEALS PROCESS

1.) Has there been an initial decision in the matter? This can be:

- \* an existing published wage determination
- \* a survey underlying a wage determination
- \* a Wage and Hour Division letter setting forth a position on a wage determination matter
- \* a conformance (additional classification and rate) ruling

On survey related matters, initial contact, including requests for summaries of surveys, should be with the Wage and Hour Regional Office for the area in which the survey was conducted because those Regional Offices have responsibility for the Davis-Bacon survey program. If the response from this initial contact is not satisfactory, then the process described in 2.) and 3.) should be followed.

With regard to any other matter not yet ripe for the formal process described here, initial contact should be with the Branch of Construction Wage Determinations. Write to:

Branch of Construction Wage Determinations  
Wage and Hour Division  
U.S. Department of Labor  
200 Constitution Avenue, N.W.  
Washington, DC 20210

2.) If the answer to the question in 1.) is yes, then an interested party (those affected by the action) can request review and reconsideration from the Wage and Hour Administrator (See 29 CFR Part 1.8 and 29 CFR Part 7). Write to:

Wage and Hour Administrator  
U.S. Department of Labor  
200 Constitution Avenue, N.W.  
Washington, DC 20210

The request should be accompanied by a full statement of the interested party's position and by any information (wage payment data, project description, area practice material, etc.) that the requestor considers relevant to the issue.

3.) If the decision of the Administrator is not favorable, an

interested party may appeal directly to the Administrative Review Board (formerly the Wage Appeals Board). Write to:

Administrative Review Board  
U.S. Department of Labor  
200 Constitution Avenue, N.W.  
Washington, DC 20210

4.) All decisions by the Administrative Review Board are final.

=====

END OF GENERAL DECISION"

Not for Bid

## CERTIFICATION REGARDING LOBBYING LOWER TIER COVERED TRANSACTIONS

Applicants should review the instructions for certification included in the regulations before completing this form. Signature on this form provides for compliance with certification requirements under 15 CFR Part 28, "New Restrictions on Lobbying."

### LOBBYING

As required by Section 1352, Title 31 of the U.S. Code, and implemented at 15 CFR Part 28, for persons entering into a grant, cooperative agreement or contract over \$100,000 or a loan or loan guarantee over \$150,000 as defined at 15 CFR Part 28, Sections 28.105 and 28.110, the applicant certifies that to the best of his or her knowledge and belief, that:

(1) No Federal appropriated funds have been paid or will be paid, by or on behalf of the undersigned, to any person for influencing or attempting to influence an officer or employee of any agency, a Member of Congress in connection with the awarding of any Federal contract, the making of any Federal grant, the making of any Federal loan, the entering into of any cooperative agreement, and the extension, continuation, renewal, amendment, or modification of any Federal contract, grant, loan, or cooperative agreement.

(2) If any funds other than Federal appropriated funds have been paid or will be paid to any person for influencing or attempting to influence an officer or employee of any agency, a Member of Congress, an officer or employee of Congress, or an employee of a member of Congress in connection with this Federal contract, grant, loan, or cooperative agreement, the undersigned shall complete and submit Standard Form-LLL, "Disclosure Form to Report Lobbying," in accordance with its instructions.

(3) The undersigned shall require that the language of this certification be included in the award documents for all subawards at all tiers (including subcontracts, subgrants, and contracts under grants, loans, and cooperative agreements) and that all subrecipients shall certify and disclose accordingly.

This certification is a material representation of fact upon which reliance was placed when this transaction was made or entered into. Submission of this certification is a prerequisite for making or entering into this transaction imposed by section 1352, title 31, U.S. Code. Any person who fails to file the required certification shall be subject to a civil penalty of not less than \$10,000 and not more than \$100,000 for each such failure occurring on or before October 23, 1996, and of not less than \$11,000 and not more than \$110,000 for each such failure occurring after October 23, 1996.

### Statement for Loan Guarantees and Loan Insurance

The undersigned states, to the best of his or her knowledge and belief, that:

In any funds have been paid or will be paid to any person for influencing or attempting to influence an officer or employee of any agency, a Member of Congress, an officer or employee of Congress, or an employee of a Member of Congress in connection with this commitment providing for the United States to insure or guarantee a loan, the undersigned shall complete and submit Standard Form-LLL, "Disclosure Form to Report Lobbying," in accordance with its instructions.

Submission of this statement is a prerequisite for making or entering into this transaction imposed by section 1352, title 31, U.S. Code. Any person who fails to file the required statement shall be subject to a civil penalty of not less than \$10,000 and not more than \$100,000 for each such failure occurring on or before October 23, 1996, and of not less than \$11,000 and not more than \$110,000 for each such failure occurring after October 23, 1996.

**As the duly authorized representative of the applicant, I hereby certify that the applicant will comply with the above applicable certification.**

NAME OF APPLICANT

AWARD NUMBER AND/OR PROJECT NAME

PRINTED NAME AND TITLE OF AUTHORIZED REPRESENTATIVE

SIGNATURE

DATE

**NOTICE OF REQUIREMENTS FOR AFFIRMATIVE ACTION  
TO ENSURE EQUAL EMPLOYMENT OPPORTUNITY  
(EXECUTIVE ORDER 11246 AND 41 CFR PART 60-4)**

The following Notice shall be included in, and shall be a part of all solicitations for offers and bids on all Federal and federally assisted construction contracts or subcontracts in excess of \$10,000.

The Offeror's or Bidder's attention is called to the "Equal Opportunity Clause" and the "Standard Federal Equal Employment Opportunity Construction Contract Specifications" set forth herein.

The goals and timetables for minority and female participation, expressed in percentage terms for the Contractor's aggregate workforce in each trade on all construction work in the covered area, are as follows:

<b>Timetables</b>	<b>Goals for minority participation for each trade</b>	<b>Goals for female participation for each trade</b>
	%	<b>6.9%</b>

These goals are applicable to all the Contractor's construction work (whether or not it is Federal or federally assisted) performed in the covered area. If the contractor performs construction work in a geographical area located outside of the covered area, it shall apply the goals established for such geographical area where the work is actually performed. With regard to this second area, the contractor also is subject to the goals for both its federally involved and non federally involved construction.

The Contractor's compliance with the Executive Order and the regulations in 41 CFR Part 60-4 shall be based on its implementation of the Equal Opportunity Clause, specific affirmative action obligations required by the specifications set forth in 41 CFR 60-4.3(a), and its efforts to meet the goals. The hours of minority and female employment and training must be substantially uniform throughout the length of the contract, and in each trade and the contractor shall make a good faith effort to employ minorities and women evenly on each of its projects. The transfer of minority or female employees or trainees from Contractor to Contractor or from project to project for the sole purpose of meeting the Contractor's goals shall be a violation of the contract, the Executive Order, and the regulations in 41 CFR Part 60-4. Compliance with the goals will be measured against the total work hours performed.

The Contractor shall provide written notification to the Director of the Office of Federal Contract Compliance Programs within 10 working days of award of any construction subcontract in excess of \$10,000 at any tier for construction work under the contract resulting from this solicitation. The notification shall list the name, address and telephone number of the subcontractor; employer identification number of the subcontractor; estimated dollar amount of the subcontract; estimated starting and completion dates of the subcontract; and the geographical area in which the subcontract is to be performed. As used in this Notice, and in the contract resulting from this solicitation, the "covered area" is:

State of \_\_\_\_\_

County of \_\_\_\_\_

City of \_\_\_\_\_

**U. S. DEPARTMENT OF COMMERCE  
ECONOMIC DEVELOPMENT ADMINISTRATION**



**EDA CONTRACTING PROVISIONS  
FOR CONSTRUCTION PROJECTS**

These EDA Contracting Provisions for Construction Projects (EDA Contracting Provisions) are intended for use by recipients receiving federal assistance from the U. S. Department of Commerce - Economic Development Administration (EDA). They contain provisions specific to EDA and other federal provisions not normally found in non-federal contract documents. The requirements contained herein must be incorporated into all construction contracts and subcontracts funded wholly or in part with federal assistance from EDA.

## **TABLE OF CONTENTS**

1. Definitions
2. Applicability
3. Federally Required Contract Provisions
4. Required Provisions Deemed Inserted
5. Inspection by EDA Representatives
6. Examination and Retention of Contractor's Records
7. Construction Schedule and Periodic Estimates
8. Contractor's Title to Material
9. Inspection and Testing of Materials
10. "OR EQUAL" Clause
11. Patent Fees and Royalties
12. Claims for Extra Costs
13. Contractor's and Subcontractor's Insurance
14. Contract Security Bonds
15. Labor Standards - Davis-Bacon and Related Acts
16. Labor Standards - Contract Work Hours and Safety Standards Act
17. Equal Employment Opportunity
18. Contracting with Small, Minority and Women's Businesses
19. Health, Safety and Accident Prevention
20. Conflict of Interest and Other Prohibited Interests
21. New Restrictions on Lobbying
22. Historical and Archaeological Data Preservation
23. Clean Air and Water
24. Use of Lead-Based Paints on Residential Structures
25. Energy Efficiency
26. Environmental Requirements
27. Debarment, Suspension, Ineligibility and Voluntary Exclusions
28. EDA Project Sign
29. Buy America

1. **DEFINITIONS**

*Agreement* – The written instrument that is evidence of the agreement between the Owner and the Contractor overseeing the Work.

*Architect/Engineer* - The person or other entity engaged by the Recipient to perform architectural, engineering, design, and other services related to the work as provided for in the contract.

*Contract* – The entire and integrated written agreement between the Owner and the Contractor concerning the Work. The Contract supersedes prior negotiations, representations, or agreements, whether written or oral.

*Contract Documents* – Those items so designated in the Agreement. Only printed or hard copies of the items listed in the Agreement are Contract Documents.

*Contractor* – The individual or entity with whom the Owner has entered into the Agreement.

*Drawings or Plans* – That part of the Contract Documents prepared or approved by the Architect/Engineer that graphically shows the scope, extent, and character of the Work to be performed by the Contractor.

*EDA* - The United States of America acting through the Economic Development Administration of the U.S. Department of Commerce or any other person designated to act on its behalf. EDA has agreed to provide financial assistance to the Owner, which includes assistance in financing the Work to be performed under this Contract. Notwithstanding EDA's role, nothing in this Contract shall be construed to create any contractual relationship between the Contractor and EDA.

*Owner* – The individual or entity with whom the Contractor has entered into the Agreement and for whom the Work is to be performed.

*Project* – The total construction of which the Work to be performed under the Contract Documents may be the whole, or a part.

*Recipient* – A non-Federal entity receiving a Federal financial assistance award directly from EDA to carry out an activity under an EDA program, including any EDA-approved successor to the entity.

*Specifications* – That part of the Contract Documents consisting of written requirements for materials, equipment, systems, standards, and workmanship as applied to the Work, and certain administrative requirements and procedural matters applicable thereto.

*Subcontractor* – An individual or entity having direct contract with the Contractor or with any other Subcontractor for the performance of a part of the Work at the Site.



*Work* – The entire construction or the various separately identifiable parts thereof required to be provided under the Contract Documents. Work includes and is the result of performing or providing all labor, services, and documentation necessary to produce such construction and furnishing, installing, and incorporating all materials and equipment into such construction, all as required by the Contract Documents.

## 2. **APPLICABILITY**

The Project to which the construction work covered by this Contract pertains is being assisted by the United States of America through federal assistance provided by the U.S. Department of Commerce - Economic Development Administration (EDA). Neither EDA, nor any of its departments, entities, or employees is a party to this Contract. The following EDA Contracting Provisions are included in this Contract and all subcontracts or related instruments pursuant to the provisions applicable to such federal assistance from EDA.

## 3. **FEDERALLY REQUIRED CONTRACT PROVISIONS**

- (a) All contracts in excess of the simplified acquisition threshold - currently fixed at \$150,000 (*see* 41 U.S.C. §§ 134 and 1908) must address administrative, contractual, or legal remedies in instances where contractors violate or breach contract terms, and provide for such sanctions and penalties as may be appropriate.
- (b) All contracts in excess of \$10,000 must address termination for cause and for convenience by the Recipient including the manner by which it will be effected and the basis for settlement.
- (c) All construction contracts awarded in excess of \$10,000 by recipients of federal assistance and their contractors or subcontractors shall contain a provision requiring compliance with Executive Order 11246 of September 24, 1965, *Equal Employment Opportunity*, as amended by Executive Order 11375 of October 13, 1967, and Department of Labor implementing regulations at 41 C.F.R. part 60.
- (d) All prime construction contracts in excess of \$2,000 awarded by Recipients must include a provision for compliance with the Davis-Bacon Act (40 U.S.C. §§ 3141-3148) as supplemented by Department of Labor regulations at 29 C.F.R. part 5. The contracts must also include a provision for compliance with the Copeland "Anti-Kickback" Act (18 U.S.C. § 874 and 40 U.S.C. § 3145) as supplemented by Department of Labor regulations at 29 C.F.R. part 3.
- (e) All contracts awarded by the Recipient in excess of \$100,000 that involve the employment of mechanics or laborers must include a provision for compliance with 40 U.S.C. §§ 3702 and 3704 (the Contract Work Hours and Safety Standards Act) as supplemented by Department of Labor regulations at 29 C.F.R. part 5.
- (f) All contracts must include EDA requirements and regulations that involve a requirement on the contractor or sub-contractor to report information to EDA, the Recipient or any other federal agency.

- (g) All contracts must include EDA requirements and regulations pertaining to patent rights with respect to any discovery or invention which arises or is developed in the course of or under such contract.
- (h) All contracts must include EDA requirements and regulations pertaining to copyrights and rights in data.
- (i) All contracts and subgrants in excess of \$150,000 must contain a provision that requires compliance with all applicable standards, orders, or requirements issued under the Clean Air Act (42 U.S.C. § 7401 *et seq.*) and the Federal Water Pollution Control Act (Clean Water Act) (33 U.S.C. § 1251 *et seq.*), and Executive Order 11738, *Providing for Administration of the Clean Air Act and the Federal Water Pollution Control Act With Respect to Federal Contracts, Grants, or Loans.*
- (j) Contracts must contain mandatory standards and policies relating to energy efficiency which are contained in the state energy conservation plan issued in compliance with the Energy Policy and Conservation Act (42 U.S.C. § 6201).
- (k) Contracts must contain a provision ensuring that contracts are not to be made to parties on the government wide Excluded Parties List System in the System for Award Management (SAM), in accordance with the OMB guidelines at 2 C.F.R. part 180.
- (l) Contracts must contain a provision ensure compliance with the Byrd Anti-Lobbying Amendment (31 U.S.C. § 1352) under which contractors that apply or bid for an award of \$100,000 or more must file the required certification. Each tier certifies to the tier above that it will not and has not used Federal appropriated funds to pay any person or organization for influencing or attempting to influence an officer or employee of any agency, a member of Congress, officer or employee of Congress, or an employee of a member of Congress in connection with obtaining any Federal contract, grant or any other award covered by 31 U.S.C. § 1352. Each tier must also disclose any lobbying with non-Federal funds that takes place in connection with obtaining any Federal award. Such disclosures are forwarded from tier to tier up to the non-Federal award.
- (m) If the Recipient is a state agency or agency of a political subdivision of a state, any contract awarded must contain a provision ensuring compliance with section 6002 of the Solid Waste Disposal Act (42 U.S.C. § 6962), as amended by the Resource Conservation and Recovery Act related to the procurement of recovered materials.

4. **REQUIRED PROVISIONS DEEMED INSERTED**

Each and every provision of law and clause required by law to be inserted in this contract shall be deemed to be inserted herein and the contract shall be read and enforced as though it were included herein, and if through mistake or otherwise any such provision is not inserted, or is not correctly inserted, then upon the application of either party the contract shall forthwith be physically amended to make such insertion of correction.

5. **INSPECTION BY EDA REPRESENTATIVES**

The authorized representatives and agents of EDA shall be permitted to inspect all work, materials, payrolls, personnel records, invoices of materials, and other relevant data and records.

6. **EXAMINATION AND RETENTION OF CONTRACTOR'S RECORDS**

(a) The Owner, EDA, or the Comptroller General of the United States, or any of their duly authorized representatives shall, generally until three years after final payment under this contract, have access to and the right to examine any of the Contractor's directly pertinent books, documents, papers, or other records involving transactions related to this contract for the purpose of making audit, examination, excerpts, and transcriptions.

(b) The Contractor agrees to include in first-tier subcontracts under this contract a clause substantially the same as paragraph (a) above. "Subcontract," as used in this clause, excludes purchase orders that do not exceed \$10,000.

(c) The periods of access and examination in paragraphs (a) and (b) above for records relating to (1) appeals under the disputes clause of this contract, (2) litigation or settlement of claims arising from the performance of this contract, or (3) costs and expenses of this contract to which the Owner, EDA, or Comptroller General or any of their duly authorized representatives has taken exception shall continue until disposition of such appeals, litigation, claims, or exceptions.

7. **CONSTRUCTION SCHEDULE AND PERIODIC ESTIMATES**

Immediately after execution and delivery of the contract, and before the first partial payment is made, the Contractor shall deliver to the Owner an estimated construction progress schedule in a form satisfactory to the Owner, showing the proposed dates of commencement and completion of each of the various subdivisions of work required under the Contract Documents and the anticipated amount of each monthly payment that will become due to the Contractor in accordance with the progress schedule. The Contractor also shall furnish the Owner (a) a detailed estimate giving a complete breakdown of the contract price and (b) periodic itemized estimates of work done for the purpose of making partial payments thereon. The costs employed in making up any of these schedules will be used only to determine the basis of partial payments and will not be considered as fixing a basis for additions to or deductions from the contract price.

8. **CONTRACTOR'S TITLE TO MATERIAL**

No materials, supplies, or equipment for the work shall be purchased by the Contractor or by any subcontractor that is subject to any chattel mortgage or under a conditional sale contract or other agreement by which an interest is retained by the seller. The Contractor warrants and guarantees that he/she has good title to all work, materials, and equipment used by him/her in the Work, free and clear of all liens, claims, or encumbrances.

9. **INSPECTION AND TESTING OF MATERIALS**

All materials and equipment used in the completion of the Work shall be subject to adequate inspection and testing in accordance with accepted standards. The laboratory or inspection agency shall be selected by the Owner. Materials of construction, particularly those upon which the strength and durability of any structure may depend, shall be subject to inspection and testing to establish conformance with specifications and suitability for intended uses.

10. **"OR EQUAL" CLAUSE**

Whenever a material, article, or piece of equipment is identified in the Contract Documents by reference to manufacturers' or vendors' names, trade names, catalogue numbers, etc., it is intended merely to establish a standard. Any material, article, or equipment of other manufacturers and vendors that will perform adequately the duties imposed by the general design will be considered equally acceptable provided the material, article, or equipment so proposed is, in the opinion of the Architect/Engineer, of equal substance and function. However, such substitution material, article, or equipment shall not be purchased or installed by the Contractor without the Architect/Engineer's written approval.

11. **PATENT FEES AND ROYALTIES**

(a) Contractor shall pay all license fees and royalties and assume all costs incident to the use in the performance of the Work or the incorporation in the Work of any invention, design, process, product, or device that is the subject of patent rights or copyrights held by others. If a particular invention, design, process, product, or device is specified in the Contract Documents for use in the performance of the Work and if, to the actual knowledge of Owner or Architect/Engineer, its use is subject to patent rights or copyrights calling for the payment of any license fee or royalty to others, the existence of such rights shall be disclosed by the Owner in the Contract Documents.

(b) To the fullest extent permitted by Laws and Regulations, the Contractor shall indemnify and hold harmless the Owner and the Architect/Engineer, and the officers, directors, partners, employees, agents, consultants, and subcontractors of each and any of them from and against all claims, costs, losses, and damages (including but not limited to all fees and charges of engineers, architects, attorneys, and other professionals and all court or arbitration or other dispute resolution costs) arising out of or relating to any infringement of patent rights or copyrights incident to the use in the performance of the Work or resulting from the incorporation in the Work of any invention, design, process, product, or device not specified in the Contract Documents.

12. **CLAIMS FOR EXTRA COSTS**

No claims for extra work or cost shall be allowed unless the same was done in pursuance of a written order from the Architect/Engineer approved by the Owner.

13. **CONTRACTORS AND SUBCONTRACTORS INSURANCE**

(a) The Contractor shall not commence work under this Contract until the Contractor has obtained all insurance reasonably required by the Owner, nor shall the Contractor allow any subcontractor to commence work on his/her subcontract until the insurance required of the subcontractor has been so obtained and approved.

(b) Types of insurance normally required are:

- (1) Workmen's Compensation
- (2) Contractor's Public Liability and Property Damage
- (3) Contractor's Vehicle Liability
- (4) Subcontractors' Public Liability, Property Damage and Vehicle Liability
- (5) Builder's Risk (Fire and Extended Coverage)

(c) **Scope of Insurance and Special Hazards:** The insurance obtained, which is described above, shall provide adequate protection for the Contractor and his/her subcontractors, respectively, against damage claims that may arise from operations under this contract, whether such operations be by the insured or by anyone directly or indirectly employed by him/her and also against any of the special hazards that may be encountered in the performance of this Contract.

(d) **Proof of Carriage of Insurance:** The Contractor shall furnish the Owner with certificates showing the type, amount, class of operations covered, effective dates, and dates of expiration of applicable insurance policies.

14. **CONTRACT SECURITY BONDS**

(a) If the amount of this Contract exceeds \$150,000, the Contractor shall furnish a performance bond in an amount at least equal to one hundred percent (100%) of the Contract price as security for the faithful performance of this Contract and also a payment bond in an amount equal to one hundred percent (100%) of the Contract price or in a penal sum not less than that prescribed by State, Territorial, or local law, as security for the payment of all persons performing labor on the Work under this Contract and furnishing materials in connection with this Contract. The performance bond and the payment bond may be in one or in separate instruments in accordance with local law. Before final acceptance, each bond must be approved by EDA. If the amount of this Contract does not exceed \$150,000, the Owner shall specify the amount of the payment and performance bonds.

(b) All bonds shall be in the form prescribed by the Contract Documents except as otherwise provided in applicable laws or regulations, and shall be executed by such sureties as are named in the current list of *Companies Holding Certificates of Authority as Acceptable Sureties on Federal Bonds and as Acceptable Reinsuring Companies* as published in Treasury Circular 570 (amended) by the Financial Management Service, Surety Bond Branch, U.S. Department of the Treasury. All bonds signed by an agent must be accompanied by a certified copy of the agent's

authority to act. Surety companies executing the bonds must also be authorized to transact business in the state where the Work is located.

15. **LABOR STANDARDS - DAVIS-BACON AND RELATED ACTS**  
**(as required by section 602 of PWEDA)**

(a) **Minimum Wages**

(1) All laborers and mechanics employed or working upon the site of the Work in the construction or development of the Project will be paid unconditionally and not less often than once a week, and without subsequent deduction or rebate on any account (except such payroll deductions as are permitted by regulations issued by the Secretary of Labor under the Copeland Act at 29 C.F.R. part 3, the full amount of wages and bona fide fringe benefits (or cash equivalents thereof) due at the time of payment computed at rates not less than those contained in the wage determination of the Secretary of Labor, which is attached hereto and made a part hereof, regardless of any contractual relationship that may be alleged to exist between the Contractor and such laborers and mechanics. Contributions made or costs reasonably anticipated for bona fide fringe benefits under Section 1(b)(2) of the Davis-Bacon Act on behalf of laborers or mechanics are considered wages paid to such laborers or mechanics, subject to the provisions of 29 C.F.R. § 5.5(a)(1)(iv); also, regular contributions made or costs incurred for more than a weekly period (but not less often than quarterly) under plans, funds, or programs, which cover the particular weekly period, are deemed to be constructively made or incurred during such weekly period. Such laborers and mechanics shall be paid the appropriate wage rate and fringe benefits on the wage determination for the classification of work actually performed, without regard to skill, except as provided in 29 C.F.R. § 5.5(a)(4). Laborers or mechanics performing work in more than one classification may be compensated at the rate specified for each classification for the time actually worked therein, provided that the employer's payroll records accurately set forth the time spent in each classification in which work is performed. The wage determination (including any additional classification and wage rates determined under 29 C.F.R. § 5.5(a)(1)(ii) and the Davis-Bacon poster (WH-1321) shall be posted at all times by the contractor and its subcontractors at the site of the work in a prominent and accessible place where it can be easily seen by the workers.

(2) (i) Any class of laborers or mechanics to be employed under the Contract, but not listed in the wage determination, shall be classified in conformance with the wage determination. EDA shall approve an additional classification and wage rate and fringe benefits therefore only when the following criteria have been met:

(A) The work to be performed by the classification requested is not performed by a classification in the wage determination;

(B) The classification is utilized in the area by the construction industry; and

(C) The proposed wage rate, including any bona fide fringe benefits, bears a

reasonable relationship to the wage rates contained in the wage determination.

(ii) If the Contractor and the laborers and mechanics to be employed in the classification (if known), or their representatives, and EDA or its designee agree on the classification and wage rate (including the amount designated for fringe benefits where appropriate), a report of the action taken shall be sent by EDA or its designee to the Administrator of the Wage and Hour Division, Employment Standards Administration, U.S. Department of Labor, Washington, D.C. 20210.

(iii) In the event the Contractor, the laborers or mechanics to be employed in the classification or their representatives, and EDA or its designee do not agree on the proposed classification and wage rate (including the amount designated for fringe benefits, where appropriate), EDA or its designee shall refer the questions, including the views of all interested parties and the recommendation of EDA or its designee, to the Administrator for determination.

(iv) The wage rate (including fringe benefits where appropriate) determined pursuant to paragraphs (a)(2)(ii) or (iii) of this section, shall be paid to all workers performing work in the classification under this contract from the first day on which work is performed in the classification.

(3) Whenever the minimum wage rate prescribed in the contract for a class of laborers or mechanics includes a fringe benefit which is not expressed as an hourly rate, the Contractor shall either pay the benefit as stated in the wage determination or shall pay another bona fide fringe benefit or an hourly cash equivalent thereof.

(4) If the Contractor does not make payments to a trustee or other third person, the Contractor may consider as part of the wages of any laborer or mechanic the amount of any costs reasonably anticipated in providing bona fide fringe benefits under a plan or program, provided, that the Secretary of Labor has found, upon the written request of the Contractor, that the applicable standards of the Davis-Bacon Act have been met. The Secretary of Labor may require the Contractor to set aside in a separate account assets for the meeting of obligations under the plan or program.

(b) **Withholding**

EDA or its designee shall upon its own action or upon written request of an authorized representative of the Department of Labor withhold or cause to be withheld from the Contractor under this Contract or any other federal contract with the same prime Contractor, or any other federally-assisted contract subject to Davis-Bacon prevailing wage requirements, which is held by the same prime contractor so much of the accrued payments or advances as may be considered necessary to pay laborers and mechanics, including apprentices, trainees and helpers, employed by the Contractor or any subcontractor the full amount of wages required by the Contract. In the event of failure to pay any laborer or mechanic, including any apprentice, trainee or helper employed or working on the site of the Work in the construction or development of the Project, all or part of the wages required by the Contract, EDA or its designee may, after written notice to the Contractor, sponsor, applicant, or owner, take such action as may be necessary to cause the suspension of any further payment, advance, or guarantee of funds until such violations

have ceased. EDA or its designee may, after written notice to the Contractor, disburse such amounts withheld for and on account of the Contractor or subcontractor to the respective employees to whom they are due. The Comptroller General shall make such disbursements in the case of direct Davis-Bacon Act contracts.

(c) **Payrolls and basic records**

(1) Payrolls and basic records relating thereto shall be maintained by the Contractor during the course of the Work and preserved for a period of three years thereafter for all laborers and mechanics working at the site of the Work in the construction or development of the Project. Such records shall contain the name, address, and social security number of each such worker, his or her correct classification, hourly rates of wages paid (including rates of contributions or costs anticipated for bona fide fringe benefits or cash equivalents thereof of the types described in section 1(b)(2)(B) of the Davis-Bacon Act), daily and weekly number of hours worked, deductions made and actual wages paid. Whenever the Secretary of Labor has found under 29 C.F.R. § 5.5(a)(1)(iv) that the wages of any laborer or mechanic include the amount of any costs reasonably anticipated in providing benefits under a plan or program described in section 1(b)(2)(B) of the Davis-Bacon Act, the Contractor shall maintain records which show that the commitment to provide such benefits is enforceable, the plan or program is financially responsible, and the plan or program has been communicated in writing to the laborers or mechanics affected, and provide records that show the costs anticipated or the actual cost incurred in providing such benefits. Contractors employing apprentices or trainees under approved programs shall maintain written evidence of the registration of apprenticeship programs and certification of trainee programs, the registration of the apprentices and trainees, and the ratios and wage rates prescribed in the applicable programs.

(2) (i) For each week in which Contract work is performed, the Contractor shall submit a copy of all payrolls to the Owner for transmission to EDA or its designee. The payrolls submitted shall set out accurately and completely all of the information required to be maintained under 29 C.F.R. part 5.5(a)(3)(i). This information may be submitted in any form desired. Optional Form WH-347 is available for this purpose. It may be purchased from the Superintendent of Documents (Federal Stock Number 029-005-00014-1), U.S. Government Printing Office, Washington, D.C. 20402; or downloaded from the U.S. Department of Labor's website at <https://www.dol.gov/whd/forms/wh347.pdf>. The prime Contractor is responsible for the submission of copies of payrolls by all subcontractors

(ii) Each payroll submitted shall be accompanied by a "Statement of Compliance," signed by the Contractor or subcontractor or his or her agent who pays or supervises the payment of the persons employed under the Contract and shall certify the following:

(A) That the payroll for the payroll period contains the information required to be maintained under 29 C.F.R. § 5.5(a)(3)(i) and that such information is correct and complete;



(B) That each laborer or mechanic (including each helper, apprentice, and trainee) employed on the Contract during the payroll period has been paid the full weekly wages earned, without rebate, either directly or indirectly, and that no deductions have been made either directly or indirectly from the full wages earned, other than permissible deductions as set forth in 29 C.F.R. part 3; and

(C) That each laborer or mechanic has been paid not less than the applicable wage rates and fringe benefits or cash equivalents for the classification of work performed, as specified in the applicable wage determination incorporated into the Contract.

(iii) The weekly submission of a properly executed certification set forth on the reverse side of Optional Form WH-347 shall satisfy the requirement for submission of the "Statement of Compliance" required by paragraph 15(c)(2)(ii) of this section.

(iv) The falsification of any of the above certifications may subject the Contractor or subcontractor to civil or criminal prosecution under section 1001 of Title 18 and section 3729 of Title 31 of the U.S. Code.

(3) The Contractor or subcontractor shall make the records required under paragraph 15(c)(1) of this section available for inspection, copying, or transcription by authorized representatives of EDA or its designee or the Department of Labor, and shall permit such representatives to interview employees during working hours on the job. If the Contractor or subcontractor fails to submit the required records or to make them available, EDA or its designee may, after written notice to the Contractor or Owner, take such action as may be necessary to cause the suspension of any further payment, advance, or guarantee of funds. Furthermore, failure to submit the required records upon request or to make such records available may be grounds for debarment action pursuant to 29 C.F.R. § 5.12.

(d) **Apprentices and Trainees.**

(1) **Apprentices.** Apprentices will be permitted to work at less than the predetermined rate for the work they performed when they are employed pursuant to and individually registered in a bona fide apprenticeship program registered with the U.S. Department of Labor, Employment and Training Administration, Bureau of Apprenticeship and Training (Bureau), or with a State Apprenticeship Agency recognized by the Bureau, or if a person is employed in his or her first 90 days of probationary employment as an apprentice in such an apprenticeship program, who is not individually registered in the program, but who has been certified by the Bureau of Apprenticeship and Training or a State Apprenticeship Agency (where appropriate) to be eligible for probationary employment as an apprentice. The allowable ratio of apprentices to journeymen on the job site in any craft classification shall not be greater than the ratio permitted to the Contractor as to the entire work force under the registered program. Any worker listed on a payroll at an apprentice wage rate who is not registered or otherwise employed as stated above, shall be paid not less than the applicable wage rate on the wage determination for the classification of work actually performed. In addition, any

apprentice performing work on the job site in excess of the ratio permitted under the registered program shall be paid not less than the applicable wage rate on the wage determination for the work actually performed. Where a Contractor is performing construction on a Project in a locality other than that in which its program is registered, the ratios and wage rates (expressed in percentages of the journeyman's hourly rate) specified in the Contractor's or subcontractor's registered program shall be observed. Every apprentice must be paid at not less than the rate specified in the registered program for the apprentice's level of progress, expressed as a percentage of the journeymen hourly rate specified in the applicable wage determination. Apprentices shall be paid fringe benefits in accordance with the provisions of the apprenticeship program. If the apprenticeship program does not specify fringe benefits, apprentices must be paid the full amount of fringe benefits listed on the wage determination for the applicable classification. If the Administrator determines that a different practice prevails for the applicable apprentice classification, fringes shall be paid in accordance with that determination. In the event the Bureau of Apprenticeship and Training, or a State Apprenticeship Agency recognized by the Bureau, withdraws approval of an apprenticeship program, the Contractor will no longer be permitted to utilize apprentices at less than the applicable predetermined rate for the work performed until an acceptable program is approved.

(2) **Trainees.** Except as provided in 29 C.F.R. § 5.16, trainees will not be permitted to work at less than the predetermined rate for the work performed unless they are employed pursuant to and individually registered in a program that has received prior approval, evidenced by formal certification by the U.S. Department of Labor, Employment and Training Administration. The ratio of trainees to journeymen on the job site shall not be greater than permitted under the plan approved by the Employment and Training Administration. Every trainee must be paid at not less than the rate specified in the approved program for the trainee's level of progress, expressed as a percentage of the journeyman's hourly rate specified in the applicable wage determination. Trainees shall be paid fringe benefits in accordance with the provisions of the trainee program. If the trainee program does not mention fringe benefits, trainees shall be paid the full amount of fringe benefits listed on the wage determination unless the Administrator of the Wage and Hour Division determines that there is an apprenticeship program associated with the corresponding journeyman wage rate on the wage determination which provides for less than full fringe benefits for apprentices. Any employee listed on the payroll at a trainee rate who is not registered and participating in a training plan approved by the Employment and Training Administration shall be paid not less than the applicable wage rate on the wage determination for the classification of work actually performed. In addition, any trainee performing work on the job site in excess of the ratio permitted under the registered program shall be paid not less than the applicable wage rate on the wage determination for the work actually performed. In the event the Employment and Training Administration withdraws approval of a training program, the Contractor will no longer be permitted to utilize trainees at less than the applicable predetermined rate for the work performed until an acceptable program is approved.

(3) **Equal employment opportunity.** The utilization of apprentices, trainees and journeymen under this part shall be in conformity with the equal employment opportunity

requirements of Executive Order 11246, *Equal Employment Opportunity*, as amended, and 29 C.F.R. part 30.

(e) **Compliance with Copeland Anti-Kickback Act Requirements.** The Contractor shall comply with the Copeland Anti-Kickback Act (18 U.S.C. § 874 and 40 U.S.C. § 3145) as supplemented by Department of Labor regulations (29 C.F.R. part 3, “Contractors and Subcontractors on Public Buildings or Public Works Financed in Whole or in Part by Loans or Grants of the United States”). The Act provides that the Contractor and any subcontractors shall be prohibited from inducing, by any means, any person employed in the construction, completion, or repair of public work, to give up any part of the compensation to which they are otherwise entitled. The Owner shall report all suspected or reported violations to EDA.

(f) **Subcontracts.** The Contractor and any subcontractors will insert in any subcontracts the clauses contained in 29 C.F.R. §§ 5.5(a)(1) through (10) and such other clauses as EDA or its designee may require, and also a clause requiring the subcontractors to include these clauses in any lower tier subcontracts. The prime Contractor shall be responsible for the compliance by any subcontractor or lower tier subcontractor with all the contract clauses in 29 C.F.R. § 5.5.

(g) **Contract termination; debarment.** The breach of the contract clauses in 29 C.F.R. § 5.5 may be grounds for termination of the contract, and for debarment as a Contractor and a subcontractor as provided in 29 C.F.R. § 5.12.

(h) **Compliance with Davis-Bacon and Related Act Requirements.** All rulings and interpretations of the Davis-Bacon and Related Acts contained in 29 C.F.R. parts 1, 3, and 5 are herein incorporated by reference in this contract.

(i) **Disputes concerning labor standards.** Disputes arising out of the labor standards provisions of this Contract shall not be subject to the general disputes clause of this Contract. Such disputes shall be resolved in accordance with the procedures of the Department of Labor set forth in 29 C.F.R. parts 5, 6, and 7. Disputes within the meaning of this clause include disputes between the contractor (or any of its subcontractors) and EDA or its designee, the U.S. Department of Labor, or the employees or their representatives.

(j) **Certification of Eligibility.**

(1) By entering into this Contract, the Contractor certifies that neither it nor any person or firm that has an interest in the Contractor's firm is a person or firm ineligible to be awarded Government contracts by virtue of section 3(a) of the Davis-Bacon Act or 29 C.F.R. § 5.12(a)(1).

(2) No part of this Contract shall be subcontracted to any person or firm ineligible for award of a Government contract by virtue of section 3(a) of the Davis-Bacon Act or 29 C.F.R. § 5.12(a)(1).

(3) The penalty for making false statements is prescribed in the U.S. Criminal Code, 18 U.S.C. § 1001.

16. **LABOR STANDARDS - CONTRACT WORK HOURS AND SAFETY STANDARDS ACT**

As used in this paragraph, the terms “laborers” and “mechanics” include watchmen and guards.

(a) **Overtime requirements.** No Contractor or subcontractor contracting for any part of the Contract work, which may require or involve the employment of laborers or mechanics, shall require or permit any such laborer or mechanic in any workweek in which that person is employed on such work to work in excess of forty hours in such workweek unless such laborer or mechanic receives compensation at a rate not less than one and one-half times the basic rate of pay for all hours worked in excess of forty hours in such workweek.

(b) **Violation; liability for unpaid wages, liquidated damages.** In the event of any violation of the clause set forth in paragraph (a) of this section, the Contractor and any subcontractor responsible therefore shall be liable for the unpaid wages. In addition, such Contractor and subcontractor shall be liable to the United States (in the case of work done under contract for the District of Columbia or a territory, to such District or to such territory), for liquidated damages. Such liquidated damages shall be computed with respect to each individual laborer or mechanic, including watchmen and guards, employed in violation of the clause set forth in paragraph (a) of this section, in the sum of \$10 for each calendar day on which such individual was required or permitted to work in excess of the standard workweek of forty hours without payment of the overtime wages required by the clause set forth in paragraph (a) of this section.

(c) **Withholding for unpaid wages and liquidated damages.** EDA or its designee shall upon its own action or upon written request of an authorized representative of the Department of Labor withhold or cause to be withheld, from any monies payable on account of work performed by the Contractor or subcontractor under any such Contract or any other federal contract with the same prime Contractor, or any other federally-assisted contract subject to the Contract Work Hours and Safety Standards Act, which is held by the same prime Contractor such sums as may be determined to be necessary to satisfy any liabilities of such Contractor or subcontractor for unpaid wages and liquidated damages as provided in the clause set forth in paragraph (b) of this section.

(d) **Subcontracts.** The Contractor or subcontractor shall insert in any subcontracts the clauses set forth in paragraphs (a) through (c) of this section and also a clause requiring the subcontractors to include these clauses in any lower tier subcontracts. The prime Contractor shall be responsible for compliance by any subcontractor or lower tier subcontractor with the clauses set forth in paragraphs (a) through (c) of this section.

17. **EQUAL EMPLOYMENT OPPORTUNITY**

(a) The Recipient hereby agrees that it will incorporate or cause to be incorporated into any contract for construction work, or modification thereof, as defined in the regulations of the Secretary of Labor at 41 C.F.R. chapter 60, which is paid for in whole or in part with funds obtained from EDA, the following equal opportunity clause:

During the performance of this contract, the Contractor agrees as follows:

Economic Development Administration  
Contracting Provisions for Construction Projects

(1) The Contractor will not discriminate against any employee or applicant for employment because of race, color, religion, sex, sexual orientation, gender identity, or national origin. The Contractor will take affirmative action to ensure that applicants are employed, and that employees are treated during employment without regard to their race, color, religion, sex, sexual orientation, gender identity, or national origin. Such action shall include, but not be limited to the following: Employment, upgrading, demotion, or transfer; recruitment or recruitment advertising; layoff or termination; rates of pay or other forms of compensation; and selection for training including apprenticeship. The Contractor agrees to post in conspicuous places available to employees and applicants for employment notices to be provided setting forth the provisions of this nondiscrimination clause.

(2) The Contractor will, in all solicitations or advertisements for employees placed by or on behalf of the Contractor state that all qualified applicants will receive consideration for employment without regard to race, color, religion, sex, sexual orientation, gender identity, or national origin.

(3) The contractor will not discharge or in any other manner discriminate against any employee or applicant for employment because such employee or applicant has inquired about, discussed, or disclosed the compensation of the employee or applicant or another employee or applicant. This provision shall not apply to instances in which an employee who has access to the compensation information of other employees or applicants as a part of such employee's essential job functions discloses the compensation of such other employees or applicants to individuals who do not otherwise have access to such information, unless such disclosure is in response to a formal complaint or charge, in furtherance of an investigation, proceeding, hearing, or action, including an investigation conducted by the employer, or is consistent with the contractor's legal duty to furnish information.

(4) The Contractor will send to each labor union or representative of workers with which it has a collective bargaining agreement or other contract or understanding, a notice to be provided advising the said labor union or workers representatives of the Contractor's commitments hereunder, and shall post copies of the notice in conspicuous places available to employees and applicants for employment.

(5) The Contractor will comply with all provisions of Executive Order 11246 of September 24, 1965 and of the rules, regulations, and relevant orders of the Secretary of Labor.

(6) The Contractor will furnish all information and reports required by Executive Order 11246 of September 24, 1965, and by rules, regulations, and orders of the Secretary of Labor, or pursuant thereto, and will permit access to its books, records, and accounts by EDA and the Secretary of Labor for purposes of investigation to ascertain compliance with such rules, regulations, and orders.

(7) In the event of the Contractor's noncompliance with the nondiscrimination clauses of

this Contract or with any of the said rules, regulations, or orders, this Contract may be canceled, terminated, or suspended in whole or in part and the Contractor may be declared ineligible for further Government contracts or federally-assisted construction contracts in accordance with procedures authorized in Executive Order 11246 of September 24, 1965, and such other sanctions may be imposed and remedies invoked as provided in Executive Order 11246 of September 24, 1965, or by rule, regulation or order of the Secretary of Labor, or as otherwise provided by law.

(8) The Contractor will include the portion of the sentence immediately preceding paragraph 17(a)(1) and the provisions of paragraphs 17(a)(1) through (8) in every subcontract or purchase order unless exempted by rules, regulations, or orders of the Secretary of Labor issued pursuant to section 204 of Executive Order 11246 of September 24, 1965, so that such provisions will be binding upon each subcontractor or vendor. The Contractor will take such action with respect to any subcontract or purchase order as EDA or the Secretary of Labor may direct as a means of enforcing such provisions, including sanctions for noncompliance. Provided, however, that in the event the Contractor becomes involved in or is threatened with litigation with a subcontractor or vendor as a result of such direction by EDA or the Secretary of Labor, the Contractor may request the United States to enter into such litigation to protect the interests of the United States.

(9) The Recipient further agrees that it will be bound by the above equal opportunity clause with respect to its own employment practices when it participates in federally-assisted construction work. Provided, however, that if the Recipient so participating is a State or local government, the above equal opportunity clause is not applicable to any agency, instrumentality, or subdivision of such government that does not participate in work on or under the Contract.

(10) The Recipient agrees that it will assist and cooperate actively with EDA and the Secretary of Labor in obtaining the compliance of contractors and subcontractors with the equal opportunity clause and the rules, regulations, and relevant orders of the Secretary of Labor, that it will furnish EDA and the Secretary of Labor such information as they may require for the supervision of such compliance, and that it will otherwise assist EDA in the discharge of the EDA's primary responsibility for securing compliance.

(11) The Recipient further agrees that it will refrain from entering into any contract or contract modification subject to Executive Order 11246 of September 24, 1965, with a Contractor debarred from, or who has not demonstrated eligibility for, Government contracts and federally assisted construction contracts pursuant to the Executive Order and will carry out such sanctions and penalties for violation of the equal opportunity clause as may be imposed upon contractors and subcontractors by EDA or the Secretary of Labor pursuant to Part II, Subpart D of the Executive Order. In addition, the Recipient agrees that if it fails or refuses to comply with these undertakings, EDA may take any or all of the following actions: Cancel, terminate, or suspend in whole or in part this EDA financial assistance; refrain from extending any further assistance to the applicant under the program with respect to which the failure or refund occurred until satisfactory assurance of future compliance has been received from such applicant; and refer the case

to the Department of Justice for appropriate legal proceedings.

(b) Exemptions to Above Equal Opportunity Clause (41 C.F.R. chapter 60):

(1) Contracts and subcontracts not exceeding \$10,000 (other than Government bills of lading, and other than contracts and subcontracts with depositories of Federal funds in any amount and with financial institutions which are issuing and paying agents for U.S. savings bonds and savings notes) are exempt. The amount of the Contract, rather than the amount of the federal financial assistance, shall govern in determining the applicability of this exemption.

(2) Except in the case of subcontractors for the performance of construction work at the site of construction, the clause shall not be required to be inserted in subcontracts below the second tier.

(3) Contracts and subcontracts not exceeding \$10,000 for standard commercial supplies or raw materials are exempt.

18. **CONTRACTING WITH SMALL, MINORITY AND WOMEN'S BUSINESSES**

(a) If the Contractor intends to let any subcontracts for a portion of the work, the Contractor shall take affirmative steps to assure that small, minority and women's businesses are used when possible as sources of supplies, equipment, construction, and services.

(b) Affirmative steps shall consist of:

(1) Placing qualified small and minority businesses and women's business enterprises on solicitation lists;

(2) Ensuring that small and minority businesses and women's business enterprises are solicited whenever they are potential sources;

(3) Dividing total requirements, when economically feasible, into smaller tasks or quantities to permit maximum participation by small and minority businesses and women's business enterprises;

(4) Establishing delivery schedules, where the requirements of the contract permit, which encourage participation by small and minority businesses and women's business enterprises;

(5) Using the services and assistance of the U.S. Small Business Administration, the Minority Business Development Agency of the U.S. Department of Commerce, and State and local governmental small business agencies;

(6) Requiring each party to a subcontract to take the affirmative steps of this section; and

(7) The Contractor is encouraged to procure goods and services from labor surplus area firms.

19. **HEALTH, SAFETY, AND ACCIDENT PREVENTION**

(a) In performing this contract, the Contractor shall:

- (1) Ensure that no laborer or mechanic shall be required to work in surroundings or under working conditions which are unsanitary, hazardous, or dangerous to their health and/or safety as determined under construction safety and health standards promulgated by the Secretary of Labor by regulation;
- (2) Protect the lives, health, and safety of other persons;
- (3) Prevent damage to property, materials, supplies, and equipment; and
- (4) Avoid work interruptions.

(b) For these purposes, the Contractor shall:

- (1) Comply with regulations and standards issued by the Secretary of Labor at 29 C.F.R. part 1926. Failure to comply may result in imposition of sanctions pursuant to the Contract Work Hours and Safety Standards Act (40 U.S.C. §§ 3701 – 3708); and
- (2) Include the terms of this clause in every subcontract so that such terms will be binding on each subcontractor.

(c) The Contractor shall maintain an accurate record of exposure data on all accidents incident to work performed under this Contract resulting in death, traumatic injury, occupational disease, or damage to property, materials, supplies, or equipment, and shall report this data in the manner prescribed by 29 C.F.R. part 1904.

(d) The Owner shall notify the Contractor of any noncompliance with these requirements and of the corrective action required. This notice, when delivered to the Contractor or the Contractor's representative at the site of the Work, shall be deemed sufficient notice of the noncompliance and corrective action required. After receiving the notice, the Contractor shall immediately take corrective action. If the Contractor fails or refuses to take corrective action promptly, the Owner may issue an order stopping all or part of the Work until satisfactory corrective action has been taken. The Contractor shall not base any claim or request for equitable adjustment for additional time or money on any stop order issued under these circumstances.

(e) The Contractor shall be responsible for its subcontractors' compliance with the provisions of this clause. The Contractor shall take such action with respect to any subcontract as EDA, or the Secretary of Labor shall direct as a means of enforcing such provisions.



20. **CONFLICT OF INTEREST AND OTHER PROHIBITED INTERESTS**

- (a) No official of the Owner who is authorized in such capacity and on behalf of the Owner to negotiate, make, accept, or approve, or to take part in negotiating, making, accepting, or approving any architectural, engineering, inspection, construction or material supply contract or any subcontract in connection with the construction of the Project, shall become directly or indirectly interested personally in this Contract or in any part hereof.
- (b) No officer, employee, architect, attorney, engineer, or inspector of or for the Owner who is authorized in such capacity and on behalf of the Owner to exercise any legislative, executive, supervisory or other similar functions in connection with the construction of the Project, shall become directly or indirectly interested personally in this Contract or in any part thereof, any material supply contract, subcontract, insurance contract, or any other contract pertaining to the Project.
- (c) The Contractor may not knowingly contract with a supplier or manufacturer if the individual or entity who prepared the Contract Documents has a corporate or financial affiliation with the supplier or manufacturer.
- (d) The Owner's officers, employees, or agents shall not engage in the award or administration of this Contract if a conflict of interest, real or apparent, may be involved. Such a conflict may arise when: (i) the employee, officer or agent; (ii) any member of their immediate family; (iii) their partner or (iv) an organization that employs, or is about to employ, any of the above, has a financial interest in the Contractor. The Owner's officers, employees, or agents shall neither solicit nor accept gratuities, favors, or anything of monetary value from the Contractor or subcontractors.
- (e) If the Owner finds after a notice and hearing that the Contractor, or any of the Contractor's agents or representatives, offered or gave gratuities (in the form of entertainment, gifts, or otherwise) to any official, employee, or agent of the Owner or EDA in an attempt to secure this Contract or favorable treatment in awarding, amending, or making any determinations related to the performance of this Contract, the Owner may, by written notice to the Contractor, terminate this Contract. The Owner may also pursue other rights and remedies that the law or this Contract provides. However, the existence of the facts on which the Owner bases such findings shall be an issue and may be reviewed in proceedings under the dispute resolution provisions of this Contract.
- (f) In the event this Contract is terminated as provided in paragraph (e) of this section, the Owner may pursue the same remedies against the Contractor as it could pursue in the event of a breach of this Contract by the Contractor. As a penalty, in addition to any other damages to which it may be entitled by law, the Owner may pursue exemplary damages in an amount (as determined by the Owner) which shall not be less than three nor more than ten times the costs the Contractor incurs in providing any such gratuities to any such officer or employee.

## 21. **RESTRICTIONS ON LOBBYING**

(a) This Contract, or subcontract is subject to 31 U.S.C. § 1352, regarding lobbying restrictions. The section is explained in the common rule, 15 C.F.R. part 28 (55 FR 6736-6748, February 26, 1990). Each bidder under this Contract or subcontract is generally prohibited from using federal funds for lobbying the Executive or Legislative Branches of the Federal Government in connection with this EDA Award.

(b) **Contract Clause Threshold:** This Contract Clause regarding lobbying must be included in each bid for a contract or subcontract exceeding \$100,000 of federal funds at any tier under the EDA Award.

(c) **Certification and Disclosure:** Each bidder of a contract or subcontract exceeding \$100,000 of federal funds at any tier under the federal Award must file Form CD-512, *Certification Regarding Lobbying – Lower Tier Covered Transactions*, and, if applicable, Standard Form-LLL, *Disclosure of Lobbying Activities*, regarding the use of any nonfederal funds for lobbying. Certifications shall be retained by the Contractor or subcontractor at the next higher tier. All disclosure forms, however, shall be forwarded from tier to tier until received by the Recipient of the EDA Award, who shall forward all disclosure forms to EDA.

(d) **Continuing Disclosure Requirement:** Each Contractor or subcontractor that is subject to the Certification and Disclosure provision of this Contract Clause is required to file a disclosure form at the end of each calendar quarter in which there occurs any event that requires disclosure or that materially affects the accuracy of the information contained in any disclosure form previously filed by such person. Disclosure forms shall be forwarded from tier to tier until received by the Recipient of the EDA Award, who shall forward all disclosure forms to EDA.

(e) **Indian Tribes, Tribal Organizations, or Other Indian Organizations:** Indian tribes, tribal organizations, or any other Indian organizations, including Alaskan Native organizations, are excluded from the above lobbying restrictions and reporting requirements, but only with respect to expenditures that are by such tribes or organizations for lobbying activities permitted by other federal law. An Indian tribe or organization that is seeking an exclusion from Certification and Disclosure requirements must provide EDA with the citation of the provision or provisions of federal law upon which it relies to conduct lobbying activities that would otherwise be subject to the prohibitions in and to the Certification and Disclosure requirements of 31 U.S.C. § 1352, preferably through an attorney's opinion. Note, also, that a non-Indian subrecipient, contractor, or subcontractor under an award to an Indian tribe, for example, is subject to the restrictions and reporting requirements.

## 22. **HISTORICAL AND ARCHAEOLOGICAL DATA PRESERVATION**

The Contractor agrees to facilitate the preservation and enhancement of structures and objects of historical, architectural or archaeological significance and when such items are found and/or unearthed during the course of project construction. Any excavation by the Contractor that uncovers an historical or archaeological artifact shall be immediately reported to the Owner and a representative of EDA. Construction shall be temporarily halted pending the notification process and further directions issued by EDA after consultation with the State Historic

Preservation Officer (SHPO) for recovery of the items. *See* the National Historic Preservation Act of 1966 (54 U.S.C. § 300101 *et seq.*, formerly at 16 U.S.C. § 470 *et seq.*) and Executive Order No. 11593 of May 31, 1971.

23. **CLEAN AIR AND WATER**

Applicable to Contracts in Excess of \$150,000

(a) **Definition.** “Facility” means any building, plant, installation, structure, mine, vessel, or other floating craft, location, or site of operations, owned, leased, or supervised by the Contractor or any subcontractor, used in the performance of the Contract or any subcontract. When a location or site of operations includes more than one building, plant, installation, or structure, the entire location or site shall be deemed a facility except when the Administrator, or a designee, of the United States Environmental Protection Agency (EPA) determines that independent facilities are collocated in one geographical area.

(b) In compliance with regulations issued by the EPA, 2 C.F.R. part 1532, pursuant to the Clean Air Act, as amended (42 U.S.C. § 7401 *et seq.*); the Federal Water Pollution Control Act, as amended (33 U.S.C. § 1251 *et seq.*); and Executive Order 11738, the Contractor agrees to:

(1) Not utilize any facility in the performance of this contract or any subcontract which is listed on the Excluded Parties List System, part of the System for Award Management (SAM), pursuant to 2 C.F.R. part 1532 for the duration of time that the facility remains on the list;

(2) Promptly notify the Owner if a facility the Contractor intends to use in the performance of this contract is on the Excluded Parties List System or the Contractor knows that it has been recommended to be placed on the List;

(3) Comply with all requirements of the Clean Air Act and the Federal Water Pollution Control Act, including the requirements of section 114 of the Clean Air Act and section 308 of the Federal Water Pollution Control Act, and all applicable clean air and clean water standards; and

(4) Include or cause to be included the provisions of this clause in every subcontract and take such action as EDA may direct as a means of enforcing such provisions.

24. **USE OF LEAD-BASED PAINTS ON RESIDENTIAL STRUCTURES**

(a) If the work under this Contract involves construction or rehabilitation of residential structures over \$5,000, the Contractor shall comply with the Lead-based Paint Poisoning Prevention Act (42 U.S.C. § 4831). The Contractor shall assure that paint or other surface coatings used in a residential property does not contain lead equal to or in excess of 1.0 milligram per square centimeter or 0.5 percent by weight or 5,000 parts per million (ppm) by weight. For purposes of this section, “residential property” means a dwelling unit, common areas, building exterior surfaces, and any surrounding land, including outbuildings, fences and play equipment affixed to the land, belonging to an owner and available for use by residents, but not

including land used for agricultural, commercial, industrial or other non-residential purposes, and not including paint on the pavement of parking lots, garages, or roadways.

- (b) As a condition to receiving assistance under PWEDA, recipients shall assure that the restriction against the use of lead-based paint is included in all contracts and subcontracts involving the use of federal funds.

25. **ENERGY EFFICIENCY**

The Contractor shall comply with all standards and policies relating to energy efficiency which are contained in the energy conservation plan issued in compliance with the Energy Policy and Conservation Act (42 U.S.C. § 6201) for the State in which the Work under the Contract is performed.

26. **ENVIRONMENTAL REQUIREMENTS**

When constructing a Project involving trenching and/or other related earth excavations, the Contractor shall comply with the following environmental constraints:

(1) **Wetlands.** When disposing of excess, spoil, or other construction materials on public or private property, the Contractor shall not fill in or otherwise convert wetlands.

(2) **Floodplains.** When disposing of excess, spoil, or other construction materials on public or private property, the Contractor shall not fill in or otherwise convert 100 year floodplain areas delineated on the latest Federal Emergency Management Agency (FEMA) Floodplain Maps, or other appropriate maps, i.e., alluvial soils on Natural Resource Conservation Service (NRCS) Soil Survey Maps.

(3) **Endangered Species.** The Contractor shall comply with the Endangered Species Act, which provides for the protection of endangered and/or threatened species and critical habitat. Should any evidence of the presence of endangered and/or threatened species or their critical habitat be brought to the attention of the Contractor, the Contractor will immediately report this evidence to the Owner and a representative of EDA. Construction shall be temporarily halted pending the notification process and further directions issued by EDA after consultation with the U.S. Fish and Wildlife Service.

27. **DEBARMENT, SUSPENSION, INELIGIBILITY, AND VOLUNTARY EXCLUSIONS**

As required by Executive Orders 12549 and 12689, *Debarment and Suspension*, 2 C.F.R. Part 180 and implemented by the Department of Commerce at 2 C.F.R. part 1326, for prospective participants in lower tier covered transactions (except subcontracts for goods or services under the \$25,000 small purchase threshold unless the subrecipient will have a critical influence on or substantive control over the award), the Contractor agrees that:

- (1) By entering into this Contract, the Contractor and subcontractors certify, that neither it nor its principals is presently debarred, suspended, proposed for debarment, declared Economic Development Administration Contracting Provisions for Construction Projects

ineligible, or voluntarily excluded from participation in this Contract by any federal department or agency.

(2) Where the Contractor or subcontractors are unable to certify to any of the statements in this certification, the Contractor or subcontractors shall attach an explanation to this bid.

*See also 2 C.F.R. part 180 and 2 C.F.R. § 200.342.*

28. **EDA PROJECT SIGN**

The Contractor shall supply, erect, and maintain in good condition a Project sign according to the specifications provided by EDA. To the extent practical, the sign should be a free standing sign. Project signs shall not be located on public highway rights-of-way. Location and height of signs will be coordinated with the local agency responsible for highway or street safety in the Project area, if any possibility exists for obstructing vehicular traffic line of sight. Whenever the EDA site sign specifications conflict with State law or local ordinances, the EDA Regional Director will permit such conflicting specifications to be modified so as to comply with State law or local ordinance.

29. **BUY AMERICA**

To the greatest extent practicable, contractors are encouraged to purchase American-made equipment and products with funding provided under EDA financial assistance awards.

## EDA PROJECT SIGN

The Contractor shall supply, erect, and maintain in good condition a project sign according to the specifications set forth below:

### EDA SITE SIGN SPECIFICATIONS

Size: 4' x 8' x ¾"

Materials: Exterior grade/MDO plywood (APA rating A-B)

Supports: 4" x 4" x 12' posts with 2" x 4" cross branching

Erection: Posts shall be set a minimum of three feet deep in concrete footings that are at least 12" in diameter.

Paint: Outdoor enamel

Colors: Jet Black, Blue (PMS300), and Gold (PMS7406). Specifically, on white background the following will be placed:

The U. S. Department of Commerce seal in blue, black, and gold;

“EDA” in blue;

“U. S. DEPARTMENT OF COMMERCE ECONOMIC DEVELOPMENT  
ADMINISTRATION” in black;

“In partnership with” in blue;

(Actual name of the) “EDA Grant Recipient” in black;

Lettering: Specific fonts are named below; positioning will be as shown on the attached illustration.

“U. S. DEPARTMENT OF COMMERCE ECONOMIC DEVELOPMENT  
ADMINISTRATION” use Bank Gothic Medium - **BANK GOTHIC MED**

“In partnership with” use Univers™ 55 Oblique - **Univers 55**

(Name of) “EDA Grant Recipient” use Univers™ Extra Black 85 **Univers 85**

Project signs will not be erected on public highway rights-of-way. If any possibility exists for obstruction to traffic line of sight, the location and height of the sign will be coordinated with the agency responsible for highway or street safety in the area.

The EDA Regional Director may permit modifications to these specifications if they conflict with state law or local ordinances.

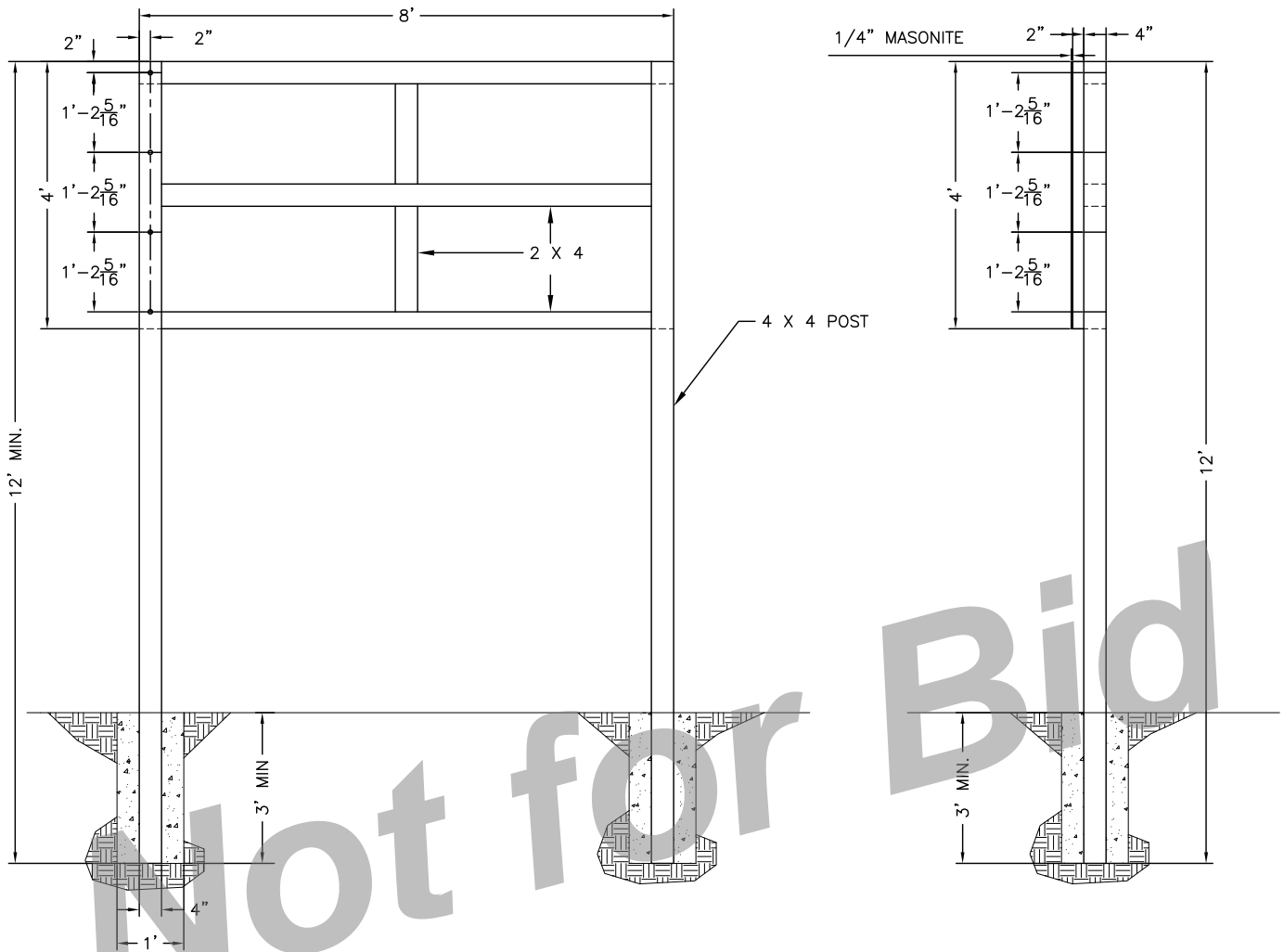

SIGN A  
MASONITE SIGN  
SCALE: 3/8" = 1'

PROJECT - SIGN A

ECONOMIC DEVELOPMENT ADMINISTRATION

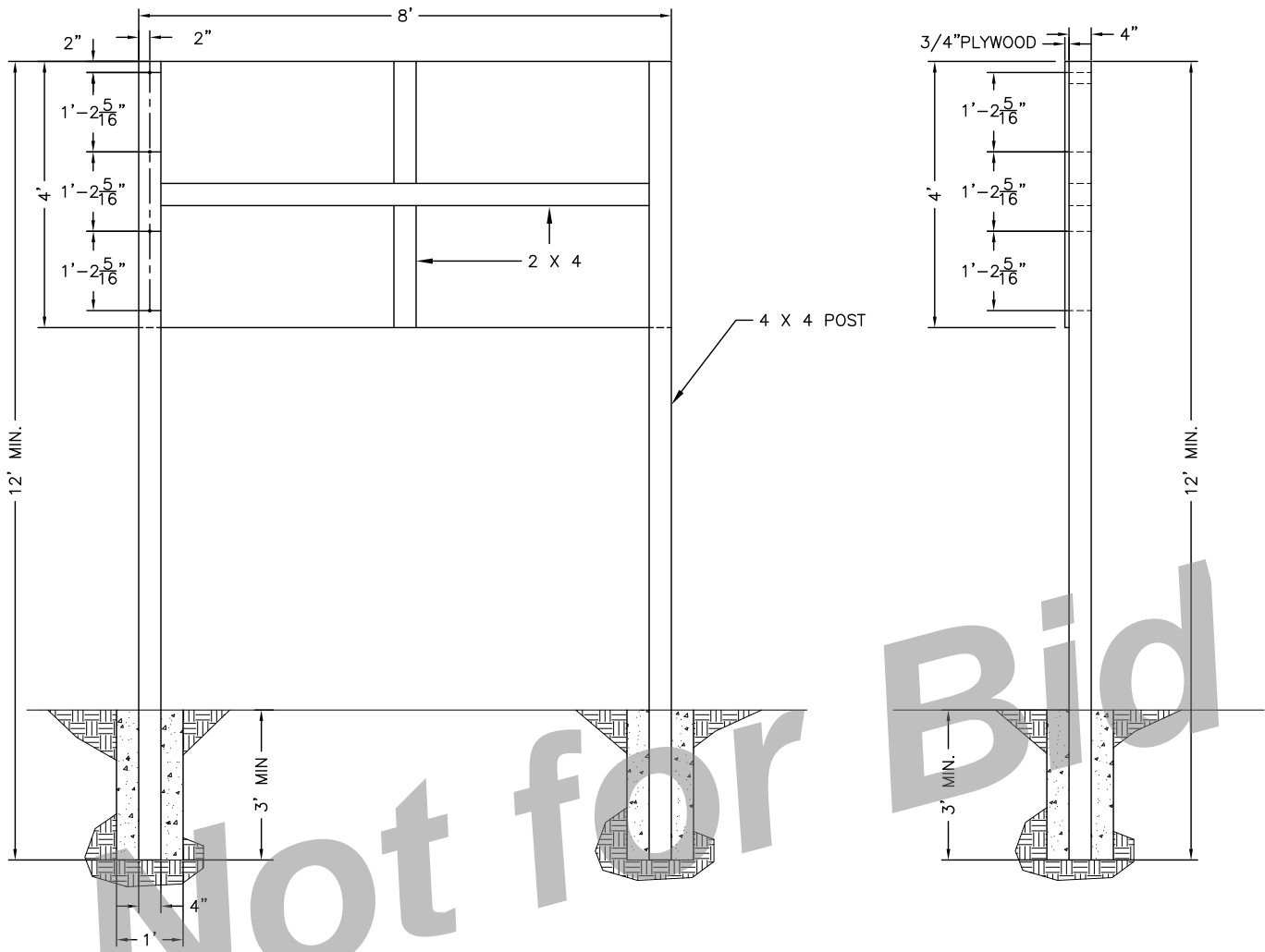

Not for Bid

SIGN B  
PLYWOOD SIGN  
SCALE: 3/8" = 1'

PROJECT - SIGN B

ECONOMIC DEVELOPMENT ADMINISTRATION





# EDA

U.S. DEPARTMENT OF COMMERCE ECONOMIC DEVELOPMENT ADMINISTRATION

*In partnership with*

**<EDA Grant Recipient Name>**

2.25"

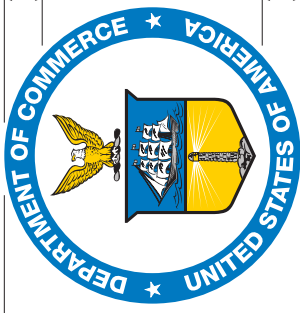

13.5"

1.75"

E

1.75"

D

A

10"

Black  
Blue= PMS300  
Gold= PMS7406

2.0"

1.5"

4.0"

3.0"

3.0"

3.75"

15.0"

U.S. DEPARTMENT OF COMMERCE ECONOMIC DEVELOPMENT ADMINISTRATION

*In partnership with*

**<EDA Grant Recipient Name>**

SECTION 01001  
GENERAL REQUIREMENTS

PART 1 - GENERAL

1.01 COMMENCEMENTS AND PROSECUTION OF WORK

- A. Contract time shall begin at which time the Owner will issue a written Notice to Proceed. The Contractor must commence construction within ten (10) days of issuance of a written Notice to Proceed. The Contractor shall maintain sufficient labor and supervision on the job until all items have been completed and the Engineer's Final Certification has been issued.

1.02 COOPERATION

- A. The General Contractor and Sub-Contractors shall cooperate with one another and with other Contractors doing related work and shall coordinate their work with the work of other trades and other Contractors so as to facilitate the general progress of the work. Each trade shall afford all other trades and all other Contractors every reasonable opportunity for the installation of their work and for storage of their materials.

1.03 SANITARY FACILITIES, TEMPORARY

- A. Do not allow any sanitary nuisances to be committed in or about work; enforce sanitary regulations of Local and State Health authorities.

1.04 SITE EXAMINATION OF EXISTING CONDITIONS

- A. The Contractor, in undertaking the work under this Contract, is assumed to have visited the premises and to have taken into consideration all conditions which might affect his work. No consideration will be given any claim based on lack of knowledge of existing conditions, except where the Contract Documents make definite provisions for adjustment of cost or extension of time due to existing conditions which cannot be readily ascertained.

1.05 SPECIFICATIONS EXPLANATION

- A. Attention is directed to the fact that the detailed specifications and separate sections may be written in short or abridged form. In regard to every section of the specifications and all parts thereof, mentioned therein or indications on the drawings or articles, materials, operations or methods require that the Contractor:
  - 1. Provide each item mentioned and indicated (of quality or subject to qualifications notes).
  - 2. Perform (according to conditions stated) each operation prescribed.
  - 3. Provide therefore all necessary labor, equipment and incidentals.

- B. Wherever in these specifications or on the drawings the words "directed", "required", "ordered", or words of like import are used, it shall be understood that the directions, requirements, permission or order of the Engineer is intended; and similar words "approved", "accepted", "satisfactory", or words of like import shall mean approved, acceptable to, or satisfactory to the Engineer.
- C. For convenience of reference and to facilitate the letting of Contracts or Sub-Contracts, these specifications are separated into titled sections. Such separation shall not, however, operate to make the Engineer an arbiter to establish limits to the Contracts between the Contractor and Sub-Contractors, nor shall such operation be interpreted as superseding normal union functions.
- D. Notwithstanding the appearance of such language in the various divisions of the specifications as "The Electrical Contractor", "The Roofing Contractor", etc., the Contractor is responsible to the Owner for the entire Contract and the execution of all work referred to in the Contract Documents.

#### 1.06 STANDARD

- A. Wherever reference is made to the standard specifications of nationally known organizations and specific articles, sections, divisions, or headings are not given, such specifications shall apply in full. Standard specifications where included herein by abbreviation or otherwise shall form a part of this specification the same as if quoted in full.
- B. The Engineer may require, and the Contractor shall furnish if required to do so, certificates from manufacturers to the effect that the products or materials furnished by them for use in the work comply with the applicable specified requirements for the materials or products being furnished.

#### 1.07 TELEPHONE, TEMPORARY

- A. Contractor shall install and maintain at his expense a job telephone for duration of the Contract.

#### 1.08 TEMPORARY UTILITIES

- A. Contractor shall furnish water, electricity, and heating fuel necessary for construction. Contractor shall provide necessary temporary piping, faucets, valves, wiring, switches, outlets, etc., to carry services to the work. The Contractor shall make all temporary utilities connection for his own use and remove temporary services on completion of Contract.

#### 1.09 WORK OUTSIDE OF THE PROPERTY LINE

- A. All work outside of the property line called for by the Contract Documents shall be performed by the Contractor and all cost for same shall be included in the Contract.

#### 1.10 AS-BUILT DRAWINGS

- A. The Contractor shall, upon completion of the work, furnish a marked set of drawings showing field changes affecting the various mechanical trades, utilities and electrical, as actually installed and as specified under those sections of the specifications, and deliver them to the Engineer. Engineer will furnish prints to Contractor for marking.

## 1.11 LIQUIDATED DAMAGES

- A. Substantial Completion - If the Contractor neglects, fails or refuses to achieve Substantial Completion of the work by not later than 12 P.M. (Midnight), the Contractor shall pay to the Owner, Liquidated Damages in the amount of three hundred dollars (\$300.00) per calendar day for each and every day that the Contractor is in default after the date indicated on the Notice to Proceed.
- B. Final Completion - If the Contractor neglects, fails, or refuses to complete the work by not later than 12 P.M. (Midnight), the Contractor shall pay to the Owner, Liquidated damages, in the amount of three hundred dollars (\$300.00) per calendar day for each and every day that the Contractor is in default after the date indicated on the Notice to Proceed. Liquidated Damages for Substantial Completion and Final Completion are cumulative.
  - 1. The said amount is fixed and agreed upon by and between the Contractor and the Owner because of the impracticability and extreme difficulty of fixing and ascertaining the actual damages the Owner would in such an event sustain, and said amount is agreed to be the amount of damages which the Owner would sustain and said amount shall be retained from time to time by the Owner from current Progress Payment should the construction progress fall behind schedule.
  - 2. Time is of the essence of each and every portion of this Contract and of the specification wherein a definite and certain length of time is fixed for the performance of any act whatsoever; and where under the Contract an additional time is allowed for the completion of any work, the new time limit fixed by such extension shall be of the essence of this Contract.
  - 3. Extensions of time applies to Liquidated Damages only and shall be allowed only for conditions over which the Contractor has no control, such as acts of God, transportation strikes affecting delivery of materials or equipment which are used in the project, manufacturing strikes affecting the production of materials or equipment which are used in the project, and weather above and beyond the normal expected loss of time based on historical climatological conditions over the last 10 years. For any time requested over what should be expected based on historical climatological conditions the amount of rain or temperature must meet the following conditions. To get credit for delays due to temperature the temperature must be at a level that would prevent construction in accordance with the other sections in these specifications. In order to get credit for rain delay the rain event must be persistent for more than four hours during that day and rainfall must be in excess of 0.5" for that 4 hour period or more than 1" during the day.

## 1.12 MATERIALS PRIOR APPROVAL AND SUBSTITUTIONS

- A. Where items of equipment and/or materials are specifically identified herein by a manufacturer's name, model or catalog number, only such specific item may be used in the base bid, except as hereinafter provided.
- B. If Contractors wish to use items of equipment and/or materials other than those specifically identified in the Specifications, Contractor shall apply in writing to the Engineer for approval of substitution at least seven (7) days prior to opening of bids, submitting with his request for approval complete descriptive and technical data on the item(s) he proposes to furnish.

- C. Approved substitutions will be listed in an addendum issued to all General Contractors prior to opening of bids.
- D. Unless requests for changes in the Specifications are approved prior to the opening of bids, as defined above, the successful Contractor will be held to furnish specified items. After contract is awarded, changes in specifications will be made only as defined under "Substitution of Equipment".

#### 1.13 SUBSTITUTION OF EQUIPMENT AND MATERIALS

- A. After execution of contract, substitution of equipment and/or materials other than those specifically named in the Contract Documents will be approved by the Engineer for the following reasons only:
  - 1. That the equipment or material is no longer available.
  - 2. That the equipment or material does not perform the function for which it was intended.
  - 3. That the equipment or material cannot be delivered due to conditions beyond the Contractor's control.
- B. To receive consideration, requests for substitutions must be in writing accompanied by documentary proof of equality, and difference in price and delivery, if any.
- C. In case of a difference in price, the Owner shall receive all benefit of the difference in cost involved in any substitutions, and the contract altered by change order to credit the Owner with any savings so obtained.

#### 1.14 INSPECTING AND TESTING OF MATERIALS

- A. Wherever in these Contract Documents inspecting and testing of material is called for, the selection of bureaus, laboratories and/or agencies for such inspecting and testing shall be made by the Engineer, and the character of the test shall be stipulated by the Engineer. Documentary evidence satisfactory to the Engineer that the materials have passed the required inspection and tests must be furnished in quadruplicate to the Engineer by the bureau, agency or laboratory selected. Materials satisfactorily meeting the requirements of the inspection or tests shall be approved by the Engineer and the Contractor notified of the results. The cost of such inspecting and testing shall be paid for by the Contractor.

#### 1.15 ON SITE TESTING AND INSPECTING

- A. Wherever in these Contract Documents testing or inspecting is called for, the selection of bureaus, laboratories and/or agencies for such testing or inspecting shall be made by the Engineer. Documentary evidence satisfactory to the Engineer that the materials have passed the required tests or inspection shall be furnished in quadruplicate to the Engineer. **The cost of such tests and inspection shall be paid for by the Contractor.**

## 1.16 MEASUREMENTS AND DIMENSIONS

- A. Before ordering materials or doing work which is dependent for proper size of installation upon coordination with site conditions, the Contractor shall verify all dimensions by taking measurements at the site and shall be responsible for the correctness of same. No consideration will be given any claim based on differences between the actual dimensions and those indicated on the drawings. Any discrepancies between the drawings and/or specifications and the existing conditions shall be referred to the Engineer for adjustment before any work affected thereby is begun.

## 1.17 SHOP DRAWINGS

- A. Shop drawings shall be dated and contain: Name of project; description and names of equipment, materials, and items; and complete identification of locations at which material or equipment is to be installed, reference to the section of the specifications where it is specified and drawings number, where shown. In addition to the above, the Shop drawings shall: (1) show complete information for checking and for fabrication, installation and erection, without reference to other drawings or note; (2) shall be of drafting line work and lettering that is easily readable under field conditions; (3) have plane oriented the same as plans on the Contract Drawings; (4) list grade, class, or strength of materials; (5) be checked and initialed by the suppliers drafting room checker; (6) be checked and coordinated with other phases of the work, by a person in the Contractor's employ who is experienced and qualified in the checking and coordination of shop drawings.
- B. Shop drawings shall not, after having been submitted, be later issued with revised or additional materials, except for items corrected during the checking by the Contractor or reviewed by the Engineer.
- C. The following notation will be used by the Engineer in his review.
  - 1. No exceptions taken. (If checked here, fabrication may be undertaken. Approval does not authorize change to contract sums unless stated in a separate letter or by change order.)
  - 2. Note markings. (If checked here, fabrication may be under taken. Contractor is to coordinate markings noted.)
  - 3. Revise and resubmit.
  - 4. Rejected.
  - 5. Engineer review is for conformance with the design concept of the project and compliance with the information given within the Contract Documents only. The Contractor is responsible for dimensions being confirmed and correlated at the site; for information that pertains solely to the fabrication processes or to means, method, techniques, sequence, and procedures of construction; and for coordination of the work of all trades.
  - 6. Failure to note a noncompliance will not prevent later rejection when the noncompliance is disclosed.

- D. Submission of Shop drawings shall be accompanied by a transmittal letter in duplicate, containing project name, Owner's project number, Contractor's name, and number of drawings, title and other pertinent data.
- E. The Contractor shall promptly submit to the Engineer, five copies for Architectural items and six copies for Engineering items, required by the Contract Documents in accordance with the aforesaid schedule so as to cause no delay in his work or in work of any other Contractor.
- F. For standard items not requiring special shop drawings for manufacture, submit six copies of manufacturer's product data showing illustrated cuts of the items to be furnished, scaled details, size dimensions, performance characteristics, capabilities, wiring diagrams, control and all other pertinent information.
- G. The Contractor shall: (1) check, coordinate, correct, stamp, date, and sign all copies of each drawing, and deliver them to the Engineer for his review; (2) identify the set of drawings he has checked; this set shall be shown by checked marks or correction that every item has been verified and with the requirements of the Contract Documents.

#### 1.18 MAINTENANCE MANUAL

- A. Contractor shall, prior to completion of contract, deliver to the Engineer, three copies of manual, assembled and bound with a hard cover, for the Owner's guidance, full details for care and maintenance of visible surfaces and of equipment included in contract.
- B. Contractor shall, for this manual, obtain from subcontractor, literature of manufacturers relating to equipment, including motors; also furnish cuts, wiring diagrams, control diagrams, instruction sheets and other information pertaining to same that will be useful to Owner in overall operation and maintenance.
- C. Where the above described manuals and data are called for under separate sections of the specifications, they are to be included in the manual description in this article.



SECTION 01150  
MEASUREMENT AND PAYMENT

PART 1 - GENERAL

1.01 QUANTITIES

- A. Quantities: Quantities listed in the Proposal are approximate only and are intended to serve as a guide in comparing bids, and may be increased or decreased without invalidating the unit price bid.
- B. Payment: Contractor shall be paid for actual in place quantities as determined by the Engineer field measurements.
- C. Discrepancies: In case of discrepancies between the figures shown in the unit prices and totals, the unit prices shall apply and the totals shall be corrected to agree with the unit price.

PART 2 - MEASUREMENT AND PAYMENT

2.01 DEMOLITION

- A. Measurement: Measurement shall be made on the basis of the percentage completed item in accordance with the plans, specifications and bid documents.
- B. Payment: Payment will be made on the basis of the completed item of work. The lump sum price shall include furnishing all labor, materials and equipment necessary to complete this item of work. Work shall include, but is not limited to, removal of existing asphalt pavement, existing concrete, existing storm drain and any other existing structures marked to be removed, concrete sidewalks, existing lights and utilities, water meters, or other material that exist and will not be used as part of this project, excavation, disposal of material at an approved site, backfill, compaction and surface restoration.

2.02 CLEARING, GRUBBING & TREE PROTECTION

- A. Measurement: Measurement shall be made on the basis of the percentage complete of the task in accordance with the plans and specifications.
- B. Payment: Payment will be made at the lump sum stated in the bid. The price bid shall include furnishing all labor, materials and equipment necessary to complete this item. Work shall include, but is not limited to, removal of all trees, shrubs and undergrowth that presently exist, preventing the construction of this project, and all trees marked on the plans to be removed. All material removed including vegetation, roots and organic mat shall be removed from the site and disposed of at a permitted site. The contractor shall take special care not to disturb the roots of trees that are marked to remain. Trees to be saved shall be marked on the plans and approved by the engineer prior. Trees to be saved shall have the appropriate tree protection installed, maintained, and removed in accordance with the plans and specifications.

### 2.03 GRADING

- A. Measurement: Measurement will be made on the basis of the percent complete of the item of work. All cut and fill quantities are based on the difference between initial topographic data and proposed contours, and spot elevations shown on the plans.
- B. Payment: Payment will be made at the lump sum price stated in the bid. Work shall include all equipment, labor and material to complete the task. This item will include, but is not limited to, excavation, fill material, material transportation and placement, grading to the lines and grades shown on the plans, compaction and stabilization.

### 2.04 CONCRETE SIDEWALK

- A. Measurement: Measurement shall be made on the basis of the number of square yards of sidewalk installed at the specified thickness and dimension as shown on the construction plans. Irregular areas such as turnouts, filler strips and intersections will be measured to the closest square yard. Prior to installation of the sidewalk all areas will be checked for compaction.
- B. Payment: Payment will be made on the basis of the number of square yards of sidewalk installed at the unit price stated in the bid. The price shall include all labor, equipment and material to complete the task. Work shall include, but not be limited to, grading, compaction, construction joints, expansion joints, fiber mesh or wire reinforcing, accommodation for sidewalk pavers, furnishing, hauling, placing and compaction of the concrete in order to bring the sidewalk to the lines, grades, and cross sections shown on the construction plans, coloring, form wrecking, final cleanup and surface restoration.

### 2.05 GRANITE ROADWAY BASE

- A. Measurement: Measurement shall be made on the basis of the number of square yards of graded aggregate base applied to the roadway at the specified thickness as shown on the construction plans. Irregular areas such as turnouts, filler strips and intersections will be measured to the closest square yard. Prior to installation of the asphalt all areas will be checked for proper thickness.
- B. Payment: Payment will be made on the basis of the number of square yards of granite crusher run (graded aggregated) base at the specified thickness applied to the roadway at the unit price stated in the bid. The price shall include all labor, equipment and material to complete the task. Work shall include, but not be limited to, the furnishing, hauling, placing and compaction of the crusher run base in order to bring the base to the lines, grades, and cross sections shown on the construction plans or established by the Engineer.

### 2.06 ASPHALT PAVING

- A. Measurement: Measurement will be made on the basis of square yard of asphalt in place, in accordance with the construction plans and accepted by the Engineer.
- B. Payment: Payment will be made on the basis of the number square yards of asphalt in place in accordance with the unit price bid as stated in the contract. Work shall include, but is not limited to, the furnishing, hauling, placing and compaction of the

asphalt in order to bring the pavement to the lines, grades and cross sections as designated on the construction plans and as determined by the Engineer. The unit price bid shall also include surface cleaning and the application of prime and tack.

#### 2.07 PRECAST CONCRETE WHEEL STOPS

- A. Measurement: Measurement shall be made on the basis of each precast concrete wheel stop that is installed in accordance with the plans and specifications.
- B. Payment: Payment will be made on the basis of each concrete wheel stop that is installed at the unit price stated in the bid. The unit price shall include furnishing all labor, materials and equipment necessary to complete the task. Work shall include, but is not limited to, steel pins, sleeves, and steel attachment spikes for wheel stop installation, steel reinforcement, furnishing, hauling and installation of precast concrete wheel stops in accordance with the construction plans and specifications.

#### 2.08 STORM DRAINPIPE & APPURTENANTS

- A. Measurement: Measurement will be made based on the linear feet of pipe or each appurtenant facility installed.
- B. Payment: Payment will be made at the unit price stated in the bid. The price shall include all labor, equipment and material required to complete the task. Work shall include, but is not limited to, excavation, dewatering, shoring, sheeting, placement of the pipe or associated structure, backfill, compaction, surface restoration and final cleanup.

#### 2.09 REGRADE EXISTING DITCH

- A. Measurement: Measurement will be based on completion of the task as described in the plan, specification and bid documents.
- B. Payment: Payment will be made at the price bid. The price shall include all labor, material and equipment to complete the installation. Work shall include, but is not limited to, establishing cut and fill grades, excavation, fill, fine grading and shoulder stabilization of the proposed drainage ditch in accordance with the plans.

#### 2.10 RETENTION FACILITY COMPLETE

- A. Measurement: Measurement will be made based on the completed task of work.
- B. Payment: Payment will be made at the price stated in the bid. The price shall include all labor, equipment and material required to complete the task. Work shall include excavation grading, outlet control facility, fine grading, maintaining the facility until full stabilized, sediment removal during construction, final clean up and surface restoration.

#### 2.11 EROSION CONTROL (Construction Exits and Concrete Washouts)

- A. Measurement: Measurement shall be made on the basis of each completed item installed and maintained through the project period.

- B. Payment: Payment will be made at the unit price stated in the bid. The price bid shall include all labor, material, and equipment necessary to complete the task. Work shall include, but is not limited to, furnishing and installing the concrete washout, installation maintenance of BMPs, providing, installing, and maintain all rock, stone and geo-textile mat, removal and disposal temporary structures from site upon site stabilization, all in accordance with “The Manual for Erosion and Sediment Control in Georgia”.

## 2.12 SILT FENCE

- A. Measurement: Measurement shall be made on the basis of each linear foot of silt fence installed in accordance with the Plans, Specifications and “The Manual for Erosion and Sediment Control in Georgia”.
- B. Payment: Payment will be in accordance with the price stated in the bid. The unit price shall include all equipment, labor and materials necessary to prevent erosion from the site. Work shall include, but not be limited to, excavation, trenching, post and fabric installation, backfill, daily inspection, re-installation of failed sections, sediment removal once its one half original height of fence. Once final stabilization has occurred, removal and disposal of fence and surface restoration of remaining disturbed area. All silt fence locations shall be approved by the Engineer prior to installation. No payment will be made for silt fence installed without approval of Engineer.

## 2.13 GRASSING

- A. Measurement: Measurement shall be made on the basis of the percent complete of the item of work in accordance with the construction plans and bid items.
- B. Payment: Payment will be made in accordance with the price stated in the bid. The unit price shall include, but is not limited to, furnishing all labor, materials and equipment necessary for the satisfactory growth of grass on all disturbed areas in accordance with plans and specifications. Work shall include, but not be limited to, furnishing all materials, fertilizer, soil samples, grass seed, raking, leveling, watering, maintenance and final surface restoration. Final payment will not occur until permanent grass is established.

## 2.14 STRIPING

- A. Measurement: Measurement will be made on the basis of each linear foot of striping installed in accordance with the construction plans and specifications.
- B. Payment: Payment will be made on the basis of each linear foot of striping installed at the unit price stated in the bid. The unit price shall include furnishing all labor, materials and equipment necessary to complete this item of work. Work shall include, but not be limited to, cleaning, drying and preparing of surfaces, applying thermoplastic roadway striping, parking striping, crosswalk striping, stop bar striping in the locations shown on the plans. All striping will be in accordance with The City of Hinesville and MUTCD standards.

## 2.15 PLANTING & IRRIGATION

- A. Measurement: Measurement will be made on the basis of the percent complete of the item of work in accordance with the plans and specifications.
- B. Payment: Payment will be made at the price bid for the completed task. Price shall include all labor, equipment, and material required to complete the task in accordance with the plans and specifications. Work shall include, but is not limited to, planting of shrubs, trees, grasses, sodding, soil, mulching, fertilizer, staking, guy ropes, pop-up spray bodies, spray heads, nozzles, micro sprayers, controllers, wiring, PVC pipe, PVC sleeves, control valves, meters, backflow preventors, drip irrigation lines, all required irrigation systems and components, watering, maintenance, final surface restoration and cleanup.

## 2.16 WATER SERVICES

- A. Measurement: Measurement shall be made on the basis of each linear foot of water service installed in accordance with the construction plans and specifications.
- B. Payment: Payment will be made at the unit price bid per linear foot. Unit price bid shall include furnishing all materials, labor and equipment necessary to complete the installation of the service. Work shall include, but not be limited to, trenching, excavation, furnishing and installing saddle, corporation cock tubing, curb stop and meter box, backflow preventers, fittings, backfill, pressure testing, disinfection, complete surface restoration and cleanup.

## 2.17 CONNECTIONS TO EXISTING WATER MAINS

- A. Measurement: Measurement shall be made on the basis of each completed connection to an existing water main.
- B. Payment: Payment will be made on the basis of the unit price stated in the bid. The unit price bid shall include all materials, equipment and labor necessary to complete the task. The task shall include, but is not limited to, locating the existing water main, trenching, excavation, connection to the existing water main, pressure testing, coring, fittings, pipe and other accessories required to complete the connection, complete backfill and compaction, surface restoration, and cleanup.

## 2.18 GRAVITY SEWERS

- A. Measurement: Measurement shall be made on the basis of each linear foot of gravity sewer line installed at the elevation and location designated on the construction plans.
- B. Payment: Payment for gravity sewers will be made at the unit price bid per linear foot. Unit price bid shall include furnishing all labor, materials and equipment necessary to complete the installation of the sewer including, but not limited to, trenching, bedding, placing of PVC sewer pipe, fittings, cleanouts, shoring and sheeting, dewatering, testing, backfill, trench compaction and complete surface restoration.

## 2.19 CONNECTIONS TO EXISTING SEWER MAINS

- A. Measurement: Measurement shall be made on the basis of each completed connection to an existing sewer main.
- B. Payment: Payment will be made on the basis of the unit price stated in the bid. The unit price bid shall include all materials, equipment and labor necessary to complete the task. The task shall include, but is not limited to, locating the existing sewer main, trenching, excavation, connection to the existing sewer main or manhole, pressure testing, coring, fittings, pipe and other accessories required to complete the connection, complete backfill and compaction, surface restoration, and cleanup.

## 2.20 MOBILIZATION

- A. Measurement: Measurement shall be made on the basis of establishing construction yard and significant progress in beginning the project. Mobilization will be limited to 5.0% of the bid price.
- B. Payment: Payment will be made at the price bid. The lump sum price shall include establishing the construction yard, beginning work and providing the owner with copies of all insurance certificates, bonds and meeting all general condition requirements.

Not for Bid

SECTION 02100  
CLEARING AND GRUBBING

PART 1 - GENERAL

1.01 DESCRIPTION

- A. Clearing shall consist of the felling, trimming, cutting and disposal of trees and other vegetation designated for removal, including down timber, snags, brush and rubbish occurring within the area to be cleared. Grubbing shall consist of the removal and disposal of stumps, roots larger than 1.5 inches in diameter and matted roots.

PART 2 - EXECUTION

- 2.01 Trees, down timber, stumps, roots, brush and other vegetation in areas to be cleared shall be removed completely, except such trees and vegetation as may be indicated or directed to be left standing. Trees to be left standing within the cleared areas shall be trimmed of dead branches 1.5 inches or more in diameter.
- 2.02 Limbs and branches to be trimmed shall be neatly cut close to the bore of the tree or main branches. Cuts more than 1.5 inches in diameter shall be painted with commercial tree-wound paint.
- 2.03 All organic materials, masonry, concrete or metallic debris in the clearing and grubbing areas shall be excavated and removed to a depth of not less than 12 inches below grade where original grade is to remain level and two feet below finish grade, all material shall be removed when under pavement base and bottom of footings.
- 2.04 Depressions made by grubbing shall be backfilled and compacted with fill material to meet the requirement for trenching and structural backfilling.
- 2.05 Machine grubbing shall not be done under trees left standing in the area covered by the branches, nor in any manner which might damage the trees or any new work.
- 2.06 Trees and vegetation to be left standing shall be protected from damage during clearing, grubbing and construction operations, by the erection of barriers.
- 2.07 Damages caused by the execution of clearing and grubbing shall be paid for by the Contractor.
- 2.08 Objects above or below grade interfering with construction to be removed as directed by the Engineer.
- 2.09 Disposal of Materials
  - A. Cleared and grubbed materials to be disposed of to an approved off-site disposal area.
  - B. On site burning will not be allowed, without written permission of local authorities.

SECTION 02210  
SITE GRADING

PART 1 - GENERAL

1.01 QUALITY ASSURANCE

A. Reference Standards:

1. Standards of American Society for Testing and Materials:

ASTM-D-698 Moisture-Density Relations of Soils Using 5.5 lb. (2.5 KG) Hammer and 12 inch (304.8 mm) Drop

2. Methods of Sampling and Testing of American Association of State Highway and Transportation Officials (AASHTO), latest edition.

1.02 TESTING

A. All soil testing shall be performed by an Independent Testing Laboratory selected by the Engineer and paid for by the Contractor.

1.03 EXCESS EXCAVATED MATERIALS

A. Excess excavated materials shall be wasted off site by the Contractor at no expense to Owner, or as directed by the Engineer.

1.04 BORROW MATERIAL

A. Any borrow material required to accomplish all levels, lines and grades indicated shall be furnished by the Contractor at no expense to the Owner.

B. Borrow material shall be obtained from borrow pits off site.

C. The Contractor shall pay for all soil analysis for borrow material.

1.05 EXCAVATED MATERIAL

A. All material to be excavated shall be classified as earth.

1.06 UNSUITABLE BEARING MATERIALS

A. Should unsuitable bearing materials be encountered at levels indicated and found to have insufficient bearing values the Engineer may order the excavation carried to lower depths.

B. Compensation for the removal and/or replacement of unsuitable materials shall be in accordance with the General Conditions, Article 10.01.

C. Excavation of unsuitable bearing materials shall not proceed until the conditions have been observed by the Engineer and written approval has been given by the Owner.



## PART 2 - EXECUTION

### 2.01 TOP SOIL

- A. Areas to be stripped shall first be scraped clean of all brush, weeds, grass, roots and other material.
- B. Remove topsoil from areas to be graded and stockpile in locations where it will not interfere with structures, roads or utility operations.
- C. Topsoil shall be free from subsoil, debris and stones larger than 2 inches in diameter. The stored topsoil shall be left in piles to be used for finished grading.
- D. Stockpiles shall be protected from contamination by undesirable foreign matter and shall be graded to shed water.

### 2.02 EXCAVATION

- A. Excavations shall be accomplished to bring surface to the levels, lines and grades as indicated.
- B. Excavated material to be used for fill or backfill material shall be stockpiled on the site as directed by the Engineer. Stockpiles shall be graded to shed water.

### 2.03 FILLING

- A. All fill material required to bring areas to the levels, lines and grades indicated shall be selected and approved materials from approved borrow areas.
- B. Sub-grades on which fill material is to be placed shall be scarified to a depth of not less than 4 inches by plowing or discing. A layer of suitable fill material, approximately 3 inches in depth, shall be spread over the scarified surface and compacted.
- C. Fill material shall be spread and compacted in successive uniform layers not exceeding 8 inches in depth (loose measure) until the total thickness of fill is completed.

### 2.04 COMPACTION

- A. Compaction required for material fill shall be 95% of Standard Proctor, maximum dry density as determined by the procedures of ASTM D-698. Fill areas shall be crowned and sloped to drainage ditches or as required to prevent ponding of surface water.
- B. Compaction by flooding of any material is not acceptable. In the event that any flooding takes place, the material and all adjacent softened material shall be removed and replaced with compacted fill at no cost to the Owner.

2.05 FINISH GRADE

- A. Distribute topsoil evenly to levels, lines and grades shown.
- B. Finish grade to be trimmed and raked true to line and grade to avoid surface ponding.
- C. Remove stone two inches or greater in diameter and debris from soil.
- D. Finish grade tolerance to +/- 0.05 foot for roadways and +/- 0.10 foot for other areas.

Not for Bid

SECTION 02221  
TRENCH EXCAVATION, BACKFILL AND COMPACTION

PART 1 - GENERAL

1.01 SCOPE, STANDARDS & DEFINITIONS

- A. Work under this section shall consist of furnishing all materials, equipment and labor for excavation, trenching and backfilling for utility systems. "Utility systems" shall include underground piping and appurtenances for water distribution systems, storm water drains, sewage collection systems, force mains, spray irrigation system and all other pipes and appurtenances shown on the drawings.
- B. Applicable Standards and Reference
  - I. ASTM D2321 Soil Classification and Restrictions
    - a. Class IA = Manufactured crushed stone, shell, crushed slag or rock, open graded, clean, large voids, contains no fines, can allow sand migration to create excessive settling. Suitable as drainage blanket.
    - b. Class IB = Manufactured aggregate dense graded, clean, crushed stone with sand and gradation present. Closer void so little migration of sand, little fines. Minimal migration of sand. Suitable as drainage blanket.
    - c. Class II = Coarse grained soils and sand, graded gravel and sandy mix, minimal migration of silt or sand, use as drainage blanket and drains limited.
    - d. Class III = Coarse grain sand with fines, silty gravel, gravel-sand-silt mixture, clayey gravels, silty sand mixture. Not to be used in the presence of water.
    - e. Class IVA = Fine grain soils, inorganic, Inorganic silts and very fine sand, silty clayey fine sands, inorganic clay with minor plasticity. Lean clay. Use only where no water exists and shallow fills.
    - f. Class IVB = Fine Grained soils inorganic, micaceous fine sand, silty soil, fat clay, clay with high plasticity. Use requires geotechnical evaluation.
    - g. Class V = Organic soils, clay and silt with organics. No permitted use other than top 6" outside roadways for soil amendment for grassing.

1.02 EXISTING UTILITIES

- A. Before opening trenches, the Contractor shall examine all available records and explore for the location of all sub-surface pipes, valves or other structures and reference such locations on the surface.
- B. In opening trenches, every effort shall be made not to interfere with these utilities structures. Expose existing piping by hand before excavating by machine. Excavate existing utilities sufficiently in advance of pipe laying to determine crossing arrangement. Slight deviations may be permitted in order to clear such structures. The Contractor shall be entirely responsible for the preservation of all underground or overhead utility lines and structures, such as gas, water, sewer lines, telephone conduit, power lines, etc., and shall replace, adjust or repair, without additional compensation, any such lines damaged or interfered with as a result of this construction.

- C. Schedule work to keep roads and utilities in usable condition; coordinating all operation with the Owner to avoid inconvenience insofar as practicable.

#### 1.03 EXCAVATED MATERIAL

- A. All material to be excavated shall be classified as earth.

#### 1.04 BORROW MATERIAL

- A. Any borrow material required to accomplish all levels, lines and grades indicated shall be furnished by the Contractor at no expense to the Owner.
- B. Borrow material shall be obtained from borrow pits off site.
- C. The Contractor shall pay for all soils analysis for borrow material.

#### 1.05 TESTING

- A. All soil testing shall be performed by an Independent Testing Laboratory selected by the Engineer and paid for by the Contractor.

#### 1.06 QUALITY ASSURANCE

- A. All excavation within the rights of way of city streets and county, State or Federal roadways, shall be backfilled in accordance with the then prevailing requirements of the Georgia Department of Transportation, Highway Division.
- B. Reference Standards: Methods of Sampling and Testing of American Association of State Highway and Transportation Officials (AASHTO).

### PART 2 - EXECUTION

#### 2.01 GENERAL EXCAVATION

- A. The Contractor shall do all excavation of whatever substances encountered to depth shown on plans. Excavated materials not required for fill or backfill shall be removed from site as directed by the Engineer.
- B. Contractor is to excavate to provide 3 foot minimum cover over utility.
- C. Excavation for manholes and other accessories to have 12 inches minimum and 24 inch maximum clearance on all sides.
- D. Excavation shall not be carried below the required level.
- E. Where excavation is carried below grades indicated, the Contractor shall refill same to the proper grade with compacted earth or stone, or as directed by the Engineer.
- F. Banks of trenches shall be vertical.

- G. Width of trench shall be as shown on the plans. The bottom of trench for sewers and culverts shall be rounded so that an arc of the circumference equal to 0.6 of the outside diameter of the pipe rests on undisturbed soil.
- H. Bell holes shall be excavated accurately to size by hand.

2.02 UNSUITABLE BEARING MATERIALS

- A. Should unsuitable bearing materials be encountered at levels indicated and found to have insufficient bearing values the Engineer may order the excavation carried to lower depth.
- B. Compensation for the removal and/or replacement of unsuitable bearing materials shall be in accordance ASTM D2321 requirements.
- C. Excavation of unsuitable bearing materials shall not proceed until the conditions have been observed by the Engineer and written approval is given by the Owner.

2.03 PIPE BEDDING

- A. The following detail provides trench & pipe zone terminology.

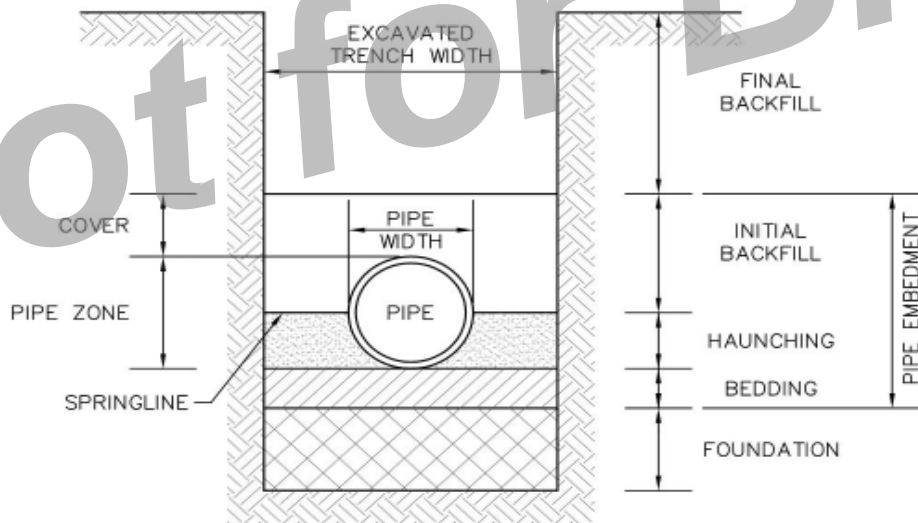

PIPE BEDDING DETAIL  
N.T.S.

- B. The trench floor should be constructed to provide firm, stable, and uniform support for the full length of the pipe. This can be accomplished by bringing the entire trench floor level grade and then creating bell holes at each joint to permit proper joint assembly, alignment and support. Portions of the trench that are excavated below grade should be returned to grade and compacted as required to provide proper support. If native trench soil is not suitable for pipe bedding, the trench should be over excavated and refilled with suitable foundation material either local sandy material compacted to 90% Std. Proctor or #57 stone depending on the presence of water and, as approved by the engineer. Bedding material shall be Class IB or II as defined in ASTM D2321. Large rocks or hard material should not be contained in the bedding area (minimum of 4") below the pipe.
- C. The most important factor in assuring proper pipe-soil interaction is the haunching material and its density. This material provides the majority of the support that the pipe requires to function properly in regards to deflection and performance. The haunching material shall be placed and compacted under the pipe haunches as shown in the detail above. Proper control should be exercised to avoid deflecting the pipe from proper alignment. The same material that is used for bedding should be used for haunching and compacted to the same standards. Haunching material shall be Class IB or II as defined in ASTM D2321.
- D. Initial backfill, as shown in the detail above, shall be accomplished with suitable, compactable material and compacted in 6" layers. Material shall meet the requirements of Class IB II or III as restricted in ASTM D2321.
- E. Final Backfill will be accomplished by placing material in 12" lifts and compacting to a level determined by the final use of the area above the pipe. Final backfill in roadways shall require placement of suitable Class IA, IB, II and III backfill material, placed in 12" lifts and compacted to 100% standard proctor (ASTM Test D-698). Final Backfill outside of roadways shall be Class II, III or IVA and lightly compacted to avoid settling in the future. The top 6" of the final backfill, outside of roadways, shall be suitable for establishing a final grassed surface.
- F. Material used in the "trench & pipe zone" shall be restricted as per the limitations and restrictions as outlined in ASTM D2321

#### 2.04 BRACING AND SHORING

- A. The Contractor shall do all bracing, sheeting and shoring necessary to perform and protect all excavations as required for safety.
- B. Sheeting driven alongside the pipe should be cut off and left in place to an elevation 1.5 feet above the top of the pipe.
- C. All other sheeting shall be removed as directed by the Engineer.

## 2.05 DEWATERING FOR EXCAVATION

- A. The Contractor shall pump or remove any water accumulated in any excavated area and shall perform all work necessary to keep excavations clear of water while foundations, structures or any masonry are being constructed or while pipe is being laid.
- B. No structure or pipe shall be laid in water, and water shall not be allowed to flow over or rise upon any concrete or masonry or piping until same has been inspected and the mortar or joint material has cured.
- C. No extra compensation will be allowed for removal of water.
- D. All water pumped or bailed from the trenches or other excavation shall be conveyed to a point of discharge where it will neither cause a hazard to the public health, nor damage to the public or private property, or to work completed or in progress.

## 2.06 BACKFILL

- A. The soil at the sides of a pipe and above it is the backfill.
- B. Prior to backfilling any excavation, all piping and structures shall be observed by the Engineer.
- C. After pipes have been tested and approved, backfilling shall be done with approved material free from large clods or stones.
- D. Backfill shall be placed in uniform layers, four inches thick, on both sides of the pipe and thoroughly compacted with pneumatic or hand tampers. The backfill shall be brought up uniformly on both sides of the pipe and compacted to an elevation of one foot above the top of the pipe, after which the fill shall be placed in eight inch lifts. No rock will be allowed in the backfill within a distance of one foot from the pipe, and rock larger than six inches in the greatest dimension will not be permitted in any part of the trench or backfill.
  - 1. Backfill shall be compacted to not less than 95% of the maximum dry weight per cubic foot as determined by AASHTO Method T-99 (Standard Proctor Test).
  - 2. The top 18 inches of backfill under any paved area shall be compacted to 100% Standard Proctor.
  - 3. Water settling will not be permitted in clay soils. It may be required at the option of the Engineer in sandy soils.

## 2.07 REPLACING PAVEMENTS

- A. Subgrades shall be compacted with a mechanical tamper.
- B. The minimum width of replaced concrete pavements shall be 4 feet at interiors and 6 feet at joints and constructed as shown on Standard Details. Avoid cutting pavements at joints; if unavoidable, reconstruct same as original joint. Depth shall be equal to the original thickness. Existing pavements edges shall be cut vertical.

- C. Use high-early-strength cement if road is to be opened in less than 3 days.
- D. The minimum width of replaced bituminous pavements shall be 3 feet with 8 inch concrete patch. The existing pavement shall be cut vertically and horizontally to a straight line. The 8 inch concrete patch shall be minimum 3,000 psi concrete containing black dye and shall be flush with the existing pavement.

Not for Bid



SECTION 02415  
SITE DEMOLITION

PART 1 - GENERAL

1.1 DESCRIPTION:

This section specifies demolition and removal of buildings, portions of buildings, utilities, other structures and debris from trash dumps shown.

1.2 RELATED WORK:

- A. Demolition and removal of roads, walks, curbs, and on-grade slabs outside buildings to be demolished:
- B. Safety Requirements: GENERAL CONDITIONS Article, ACCIDENT PREVENTION.
- C. Disconnecting utility services prior to demolition: Section 01 00 00, GENERAL REQUIREMENTS.
- D. Reserved items that are to remain the property of the Owner.
- E. Asbestos Removal: See Hazardous Material Sections of General Conditions
- F. Lead Paint: See Hazardous Material Sections of General Conditions
- G. Environmental Protection: See Erosion and Sedimentation Control Specification
- H. Construction Waste Management: See General Requirements Specification

1.3 PROTECTION:

- A. Perform demolition in such manner as to eliminate hazards to persons and property; to minimize interference with use of adjacent areas, utilities and structures or interruption of use of such utilities; and to provide free passage to and from such adjacent areas of structures. Comply with requirements of GENERAL CONDITIONS Article, ACCIDENT PREVENTION.
- B. Provide safeguards, including warning signs, barricades, temporary fences, warning lights, and other similar items that are required for protection of all personnel during demolition and removal operations.
- C. Maintain fences, barricades, lights, and other similar items around exposed excavations until such excavations have been completely filled.
- D. Provide enclosed dust chutes with control gates from each floor to carry debris to truck beds and govern flow of material into truck. Provide overhead bridges of tight board or

prefabricated metal construction at dust chutes to protect persons and property from falling debris.

- E. Prevent spread of flying particles and dust. Sprinkle rubbish and debris with water to keep dust to a minimum. Do not use water if it results in hazardous or objectionable condition such as, but not limited to; ice, flooding, or pollution. Vacuum and dust the work area daily.
- F. In addition to previously listed fire and safety rules to be observed in performance of work, include following:
  - 1. No wall or part of wall shall be permitted to fall outwardly from structures.
  - 2. Maintain at least one stairway in each structure in usable condition to highest remaining floor. Keep stairway free of obstructions and debris until that level of structure has been removed.
  - 3. Wherever a cutting torch or other equipment that might cause a fire is used, provide and maintain fire extinguishers nearby ready for immediate use. Instruct all possible users in use of fire extinguishers.
  - 4. Keep hydrants clear and accessible at all times. Prohibit debris from accumulating within a radius of 4500 mm (15 feet) of fire hydrants.
- G. Before beginning any demolition work, the Contractor shall survey the site and examine the drawings and specifications to determine the extent of the work. The contractor shall take necessary precautions to avoid damages to existing items to remain in place, to be reused, or to remain the property of the Owner; any damaged items shall be repaired or replaced as approved by the Resident Engineer. The Contractor shall coordinate the work of this section with all other work and shall construct and maintain shoring, bracing, and supports as required. The Contractor shall ensure that structural elements are not overloaded and shall be responsible for increasing structural supports or adding new supports as may be required as a result of any cutting, removal, or demolition work performed under this contract. Do not overload structural elements. Provide new supports and reinforcement for existing construction weakened by demolition or removal works. Repairs, reinforcement, or structural replacement must have Resident Engineer's approval.

H. The work shall comply with the requirements of the Erosion and Sediment Control Specification and other sections of this specification

I. The work shall comply with the requirements of GENERAL REQUIREMENTS

#### 1.4 UTILITY SERVICES:

A. Demolish and remove outside utility service lines shown to be removed.

B. Remove abandoned outside utility lines that would interfere with installation of new utility lines and new construction.

#### PART 2 - PRODUCTS (NOT USED)

#### PART 3 – EXECUTION

##### 3.1 DEMOLITION:

A. Completely demolish and remove buildings and structures, including all appurtenances related or connected thereto, as noted below:

1. In accordance with Building Demolition Specification

2. As required for installation of new utility service lines.

3. To full depth within an area defined by hypothetical lines located 1500 mm (5 feet) outside building lines of new structures.

B. Debris, including brick, concrete, stone, metals and similar materials shall become property of Contractor and shall be disposed of by him daily, off the project site to avoid accumulation at the demolition site. Materials that cannot be removed daily shall be stored in areas specified by the Resident Engineer. Break up concrete slabs below grade that do not require removal from present location into pieces not exceeding 600 mm (24 inches) square to permit drainage. Contractor shall dispose debris in compliance with applicable federal, state or local permits, rules and/or regulations.

C. Remove and legally dispose of all materials, other than earth to remain as part of project work, from any trash dumps shown. Materials removed shall become property of contractor and shall be disposed of in compliance with applicable federal, state or local permits, rules and/or regulations to a permitted site. All materials in the indicated trash dump areas, including above surrounding grade and extending to a depth of 1500mm (5feet) below surrounding grade, shall be included as part of the lump sum compensation for the work of this section. Materials that are located beneath the surface of the surrounding ground more than 1500 mm (5 feet), or materials that are discovered to be

hazardous, shall be handled as unforeseen. The removal of hazardous material shall be referred to Hazardous Materials specifications.

- E. Remove existing utilities as indicated or uncovered by work and terminate in a manner conforming to the nationally recognized code covering the specific utility and approved by the Resident Engineer. When Utility lines are encountered that are not indicated on the drawings, the Resident Engineer shall be notified prior to further work in that area.

### 3.2 CLEAN-UP:

On completion of work of this section and after removal of all debris, leave site in clean condition satisfactory to Resident Engineer. Clean-up shall include off the off site disposal of all items and materials not required to remain property of the Owner as well as all debris and rubbish resulting from demolition operations.

Not for Bid

SECTION 02520  
STORM DRAINAGE AND APPURTENANCES

PART 1 - GENERAL

1.01 APPLICABLE STANDARDS

- A. Appurtenances shall be constructed in accordance with the referenced Georgia Department of Transportation Standard Drawings.
- B. American Society for Testing and Materials (ASTM):
  - C- 32 Specification for Sewer and Manhole Brick.
  - C- 76 Reinforced Concrete Culvert, Storm Drain and Sewer Pipe.
  - C-144 Aggregate for Masonry Mortar.
  - C-270 Mortar for Unit Masonry
  - C-443 Joints for Circular Concrete Sewer and Culvert Pipe, Using Rubber Gaskets.
  - C-913 Specification for Precast Concrete Water and Wastewater Structures
  - C-536 Test for Continuity of Coatings in Glassed Steel Equipment by Electrical Testing.
- C. Only reinforced concrete pipe will be allowed under roadways or frequently traveled areas.

PART 2 - PRODUCTS

2.01 MATERIALS

- A. Roadway Storm Drainage Pipe: Pipe shall be reinforced Concrete Pipe which conforms to ASTM Specification C-76 and shall be of sizes shown. Pipe shall be Class III minimum and as indicated on GA. D.O.T. Standard 1030 D.
- B. Non-Roadway Storm Drainage Pipe: Pipe shall be one of the following:
  - 1. Corrugated metal pipe shall conform to AASHTO designation M-36, AREA Manual 1-4 requirements for corrugated metal culverts, or Federal Specification QQ-C- 806, with the following applicable requirements:
    - a. The outside and inside surfaces of the corrugated metal pipe shall be completely coated with bituminous material with a minimum thickness of 0.05 inch at the crest of the corrugations. Immediately prior to the application of the bituminous coating, the corrugated metal pipe shall be cleaned of all dirt, grease, mill scale, or loose rust and shall be dry.

- b. The outside and inside surfaces of the corrugated metal pipe shall be completely coated with a pure aluminum coating metallurgically bonded by an alloy layer between the steel and the aluminum. The coating shall be applied at a minimum of 1 oz./sq.ft., 2 mils. each side. The weight of aluminum (total both sides) shall be as follows: Minimum check limit triple-spot test=1.00 oz/sq feet, minimum check limit single-spot test=0.90 oz/sq feet. The aluminized steel pipe shall be Armco Aluminized Steel Type 2 or equal.
  - c. All rivets shall be placed in the inside valley of the corrugations. The interior coating shall be protected against damage from insertion or removal of struts or tie wires. Lifting lugs, where used, shall be so placed as to facilitate moving the pipe without damage to the exterior or interior coating. All lateral pipe shall be sixteen (16) gauge. All pipe under possible traffic areas will be twelve (12) or fourteen (14) gauge as indicated.
  - d. To facilitate field jointing, the ends of pipes with helical corrugations shall be rerolled to form circumferential corrugations from the end. The diameter of the reformed ends shall not exceed that of the pipe barrel by more than the depth of the corrugation.
2. Polyvinyl chloride (PVC) pipe shall be manufactured and tested in accordance with specification for "Poly (Vinyl Chloride) PVC Large Diameter Ribbed Gravity Sewer Pipe and Fittings Based on Controlled Inside Diameter." The pipe and fittings shall be made of PVC plastic and shall have a smooth (not ribbed or corrugated) inside surface.
    - a. All pipe shall be bell and spigot. The bell shall consist of an integral wall section or an internal plastic sleeve. The solid cross section rubber ring shall be factory assembled on the spigot. Size and dimensions shall be as shown on the plans. Standard laying length shall be 13 feet  $\pm$  1 inch.
    - b. All fittings and accessories shall be as manufactured and furnished by the pipe supplier or approved equal and have bell and/or spigot configurations compatible with that of the pipe.
    - c. Pipes shall be designed to pass all tests described herein at 73° F ( $\pm$  3° F).
    - d. The pipe stiffness shall equal or exceed 10 psi when tested in accordance with ASTM D 2412.
  3. High density Polyethylene (HDPE) pipe shall be manufactured for use in nonpressure storm sewer. The pipe shall be manufactured to meet AASHTO M294, Type 'S' for 12" through 36" and AASHTO MP6-96, Type 'S' OR 'D' for 42" and 48" pipe. The pipe and fittings shall be made from HDPE material and shall have a smooth (not ribbed or corrugated) inside surface.
    - a. All pipe shall be bell and spigot. The bell shall be an integral part of the pipe. The joint shall use a gasket to form a water tight connection meeting ASTM D3212. Gaskets shall be installed in the bell or in the spigot by the manufacturer. The use of Silt tight fittings may be requested in lieu of water tight connection if approved by the engineer.

- b. All fittings shall conform to AASHTO M294 or MP6-95. Fabricated fittings shall be welded on the interior and exterior at all junctions.
- c. Pipe and fittings material shall be high-density polyethylene meeting ASTM D3350.
- d. Installation shall be in accordance with ASTM D2321.
- e. Pipe may be Advanced Drainage System, Inc., N-12 or N-12 HC or Hancor Sure Lok 10-8 pipe.
- f. HDPE end sections are NOT allowed.

C. Pipe Joints:

1. Joints for concrete pipe shall be one of the following types:
  - a. Bell and spigot with rubber gaskets.
  - b. Tongue and groove with rubber gaskets.
  - c. Tongue and groove with preformed plastic gaskets.
2. Rubber Gaskets shall conform to ASTM Specification C443. Only a neutral agent shall be used as a lubricant. Preformed Plastic Gaskets shall conform to Federal Specification SS-S210, Type I-rope form.
3. Field joints of corrugated steel pipe shall maintain pipe alignment during construction and prevent infiltration of side material during the life of the installation. Circumferential and longitudinal strength shall be provided in accordance with the structural joint performance criteria of Division 2, Section 23 of the AASHTO standard specification for Highway Bridges. The bands shall be constructed in such a manner that will effectively engage the pipe ends. Coupling bands shall not be more than 3 nominal sheet thicknesses lighter than the thickness of the pipe to be connected and in no case lighter than 0.052 inches. Bolts and nuts for coupling bands shall conform to the requirements of ASTM Designation: A307.

Bands shall be furnished to lock with the circumferential corrugations, including rerolled end helical pipe. The corrugated bands shall be not less than 7 inches wide for diameter 4 to 36 inches, inclusive, and not less than 10 1/2 inches wide for all other pipe diameters.

NO DIMPLE BANDS WILL BE ALLOWED.

4. Joints for PVC pipe must be an integral bell gasketed joint which forms a silt tight joint.

D. Precast Concrete Manhole Sections:

ASTM C913, except that spacing of manhole steps or ladder rungs shall not exceed 12 inches.

E. Masonry Manholes: Shall be constructed of the following materials:

1. Brick: ASTM C32, Grade MS
2. Mortar of Masonry: ASTM C279, Type M.
3. Aggregate for Masonry Mortar: ASTM C144.
4. Water for Masonry Mortar shall be fresh, clean and potable.

F. METALS

1. Frames, Covers, and Grating: Frames, covers, and grating shall conform to AASHTO M-306-07 and shall be of grey iron castings.
2. Manhole Steps: Manhole steps shall be constructed of a number of 3 reinforcing bar encapsulated in polypropylene plastic with a non-skid tread. Finished dimensions of the steps shall be identical to that of malleable iron manhole steps. Steps to have a minimum tread width of 12 inches.

## 2.02 DELIVERY AND STORAGE

- A. Storm Drainage Pipe: Care shall be exercised in loading and unloading pipe, fittings, specials and castings at all times in order to avoid shock and damage to the materials. Lifting shall be by hoist or by rolling on skids. Dropping will not be permitted. The Contractor shall be responsible for the safe handling of all materials and no damaged materials shall be used in the work. Materials shall be inspected upon arrival at the site, and any damaged or defective materials shall be immediately removed from the site. All materials shall be stored above grade.
- B. Cementitious Materials: Cementitious materials in bags shall be stored in enclosed structures; floors shall be elevated above the ground a distance sufficient to prevent the absorption of moisture.
- C. Metal Items: Metal items, including reinforcing steel, shall be stored above grade in a manner which will not cause excessive rusting or coating with grease or other objectionable materials.
- D. PVC Pipe: PVC pipe shall be stored protected from sun light by means of covering the pipe or storing inside a building or under a covered shed. Any pipe showing signs of prolonged outside storage (i.e. faded exterior color or signs of drying) shall be rejected.
- E. Aggregates: Aggregates shall be stored on areas to prevent the inclusion of foreign material. Aggregates of different sizes shall be stored in separate piles. Stockpiles of coarse aggregate shall be built in horizontal layers not exceeding 4 feet in depth to minimize segregation. Should the coarse aggregate become segregated, it shall be remixed to conform to the grading requirements.
- F. Brick, Concrete Masonry Units and Precast Concrete Manholes: Brick, concrete masonry units and precast concrete manholes shall be handled with care to avoid chipping and breakage and shall be stored to protect them from contact with the earth and exposure to the weather and shall be kept dry until used. Masonry units or precast concrete containing frost or ice shall not be used.



## PART 3 - EXECUTION

### 3.01 DRAINAGE PIPE

- A. Each section of pipe shall be carefully examined before being laid, and defective or damaged pipe shall not be used.
- B. Under no circumstances shall pipe be laid in water, and no pipe shall be laid when trench conditions or weather are unsuitable for such work. Diversion of drainage or dewatering of trenches during construction shall be provided as necessary. Pipe shall be laid true to line and grades indicated and shall rest upon the pipe bed for the full length of each section. Runs of pipe shall be laid with outside bells or grooved ends up-grade beginning at the lower end of the pipe line. Pipe having its grade and/or joint disturbed after laying shall be removed, cleaned, and relayed.
- C. When pipes are protected by head walls or connect with drainage structures, the exposed ends of the pipe shall be placed or cut flush with the inside face of the structure. After the pipe is cut the rough edges shall be smoothed up in an approved manner. All pipe shall be laid so that markings are on top and the inner surfaces abut neatly, tightly and smoothly.
- D. All pipe in place shall be observed by the Engineer before being covered and concealed unless this requirement is waived by the City Inspector and the Design Engineer. Contractor shall clear all pipe of silt debris prior to final acceptance.

### 3.02 CORRUGATED METAL PIPE JOINTS

- A. Corrugated metal pipe shall be butted to form a smooth joint; the space between the pipe and coupling bands shall be kept free from dirt and grit so that the corrugations fit snugly. The coupling band while being tightened shall be tapped with a soft head mallet of wood, rubber or plastic to take up slack and insure a tight joint. Coupling band bolts and damaged areas of the coupling bands and pipe shall be given a coating of bituminous cement. Pipe on which the asphalt coating has been damaged to such extent that satisfactory field repairs cannot be made will be replaced.

### 3.03 CONCRETE PIPE JOINT

- A. Joint installation shall be in accordance with the recommendations of the manufacturer of the joint material. Surfaces to receive lubricants, cements or adhesives shall be clean and dry. Gaskets and jointing materials shall be affixed to the pipe not more than 24 hours prior to the installation of the pipe, and shall be protected from the sun, blowing dust and other degenerative agents at all times. Gaskets and jointing materials shall be inspected before installation of the pipe, and any loose or improperly affixed gaskets and jointing materials shall be removed and replaced.
- B. The pipe shall be aligned with the previously installed pipe, and the joint pulled together. If, while making the joint, the gasket or jointing material becomes loose and can be seen through the exterior joint recess when the joint is pulled up to within one inch of closure, the pipe shall be removed and the joint remade.

### 3.04 MASONRY WORK

- A. Mortar for Masonry: Mortar for brick masonry, rubble stone masonry, and for bedding cast iron frames in masonry shall be Type M, conforming to ASTM C270.
- B. Mortar for pargetting Masonry Walls: Mortar for pargetting masonry walls below grade shall be Type M, conforming to ASTM C270.
- C. Brickwork: Brick in circular walls shall be laid in all header courses to form full and close mortar joints, ends and sides in one operation. Vertical joints shall be radial from the center. Brickwork around pipe inlets and outlets shall not be allowed. Gaps shall be poured with concrete.
- D. Masonry Structures: Masonry structure walls shall be constructed of brick, concrete masonry units or precast concrete structural sections.

### 3.05 PRECAST CONCRETE

- A. Walls shall be constructed on a footing of cast-in-place concrete, except that precast concrete base sections may be used for precast concrete structure risers. Precast base sections shall conform to the applicable requirements for precast risers and tops in ASTM C913. Mortar that has hardened to the extent that it cannot be made workable without the addition of water shall not be used. Thickness of parget shall be not less than 1/2 inch. No pargetting will be permitted on the inside of structures. Pargetting will not be required for precast concrete structures. Joint work inside masonry structures shall be smooth.
- B. One course of brick work is allowed for leveling and adjustment. All other adjustments must be poured in place concrete with a maximum height of 24 inches.
- C. For single and double wing catch basins a concrete pad shall be poured 4 inches thick with a minimum slope of 1" per foot away from the curb and gutter and towards the box.

### 3.06 METAL WORK

- A. Iron and steel shall be formed to shape and size with sharp lines and angles. Shearing and punching shall produce clean true lines and surfaces. Casting shall be sound and free from warp, cold shuts, and blow holes that may impair their strength or appearance. Exposed surfaces shall have a smooth finish and sharp well-defined lines and arises. The necessary rivets, lugs, and brackets shall be provided.

### 3.07 FIELD TEST

- A. A light held in a drainage structure shall show a practically full circle of light through the pipe when viewed from the adjoining end of the line.
- B. Lines under pavements shall be tested for infiltration by means of a suitable weir or other measurement device as directed by the Owner. When determination of infiltration is not practicable because of dry trench conditions, an exfiltration test shall be applied by filling with water so that the hydraulic head will be at least 6 inches above the crown of the upper end and of the section being tested. The amount of leakage (infiltration or exfiltration) shall not exceed 100 gallons per inch of diameter per day per mile of pipe.

SECTION 02540  
EROSION CONTROL

PART 1 - GENERAL

1.01 The work specified in this Section consists of furnishing, installing and maintaining temporary erosion controls and temporary sedimentation controls.

1.02 DEFINITIONS

- A. Temporary erosion controls shall include grassing, mulching, watering and reseeding on-site sloped surfaces, providing berms at the top of the slopes and providing interceptor ditches at the ends of berms and at those locations which will ensure that erosion during construction will be either eliminated or minimized.
- B. Temporary sedimentation controls shall include silt dams, traps, barriers and appurtenances at the toe slopes.

PART 2 - MATERIALS

2.01 Hay bales shall be clean, seed free cereal hay type, securely bound.

2.02 Netting shall be 1/2 inch, galvanized steel chicken wire mesh.

2.03 Filter stone shall be crushed stone conforming to the Department of Transportation - State of Georgia-Standard Specifications – Construction of Transportation Systems - 2013 - Table 800.01, Size Number 3.

2.04 Rolled Erosion Control Products:

- A. Mulch Control Netting. A planar woven natural fiber or extruded geosynthetic mesh used as a temporary degradable rolled erosion product anchor loose fiber mulches  
Max. Gradient = 5:1 (H:V) in slope application  
C Factor =  $\leq 0.10$  @ 5:1 in slope application  
Max Shear stress 0.25 lb/sf in channel application  
Min. Tensile Strength ultra short (3 mo) and short (12 mo) term = 5 lbs/ft  
Min Tensile Strength extended term ((24 mo) = 25 lbs/ft
- B. Open Weave textile. A temporary degradable rolled erosion control product composed of processed natural or polymer yarns woven into a matrix, used to provide erosion control and facilitate vegetation establishment.  
Max. Gradient = 3:1 (H:V) in slope application  
C Factor =  $\leq 0.15$  @ 3:1 in slope application  
Max Shear stress = 1.5 lb/sf in channel application  
Min. Tensile Strength ultra short (3 mo) and short (12 mo) term = 50 lbs/ft  
Min Tensile Strength extended term ((24 mo) = 100lbs/ft

- C. Erosion Control Blanket. A temporary degradable rolled erosion control product composed of processed natural or polymer fibers mechanically, structurally or chemically bound together to form a continuous matrix to provide erosion control and facilitate vegetation establishment.

Netless Rolled Erosion Control Blankets:

Max. Gradient = 4:1 (H:V) in slope application

C Factor =  $\leq 0.10$  @ 4:1 in slope application

Max Shear stress = 0.5 lb/sf in channel application

Min. Tensile Strength ultra short (3 mo) and short (12 mo) term = 5 lbs/ft

Single-net Erosion Control Blankets:

Max. Gradient = 3:1 (H:V) in slope application

C Factor =  $\leq 0.15$  @ 3:1 in slope application

Max Shear stress = 1.5 lb/sf in channel application

Min. Tensile Strength ultra short (3 mo) and short (12 mo) term = 50 lbs/ft

Min Tensile Strength extended term ((24 mo) = 100lbs/ft

Double-net Erosion Control Blankets:

Max. Gradient = 2:1 (H:V) in slope application

C Factor =  $\leq 0.2$  @ 2:1 in slope application

Max Shear stress = 1.75 lb/sf in channel application

Min. Tensile Strength ultra short (3 mo) and short (12 mo) term = 75 lbs/ft

- D. Turf Reinforcement Mat. A rolled erosion control product composed of non-degradable synthetic fibers, filaments, nets, wire mesh, and/or other elements, processed into a permanent, three dimensional matrix of sufficient thickness. TRMs, which may be supplemented with degradable components, are designed to impart immediate erosion protection, enhance vegetation establishment and provide long term functionality by permanently reinforcing vegetation during and after maturation. These products are typically used in hydraulic applications such as high flow ditches, channels, steep slopes, stream banks, and shorelines, where erosive forces may exceed the limits of natural, unreinforced vegetation.
- Slope Application max gradient = 0.5:1 (H:V)  
Channel Application Max Shear Stress: 5A, B, C as defined in FHWA guidelines  
5A = 6.0 lb/sf, 5B = 8.0 lb/sf, 5C = 10.0 lbs/sf  
Min. Tensile Strength: 5A, B, C as defined in FHWA guidelines  
5A = 125.0 lb/ft, 5B = 150.0 lb/ft, 5C = 175.0 lbs/ft 5A, B, C as defined in FHWA guidelines

## PART 3 - EXECUTION

### 3.01 SEDIMENTATION CONTROL

- A. Silt dams, traps, barriers, and appurtenances shall be installed and shall be maintained in-place for duration of construction.
- B. Hay bales shall be staked with two (2) 1 x 4 wood stakes per bale driven eighteen (18) inches into the ground and finishing flush with the top of the bale.
1. Install two (2) stakes per bale with the long dimension of the stakes parallel to the long dimension of the bale.

2. Where bales are installed in multiple layers the bales shall be installed with vertical joints staggered and two (2) 1 x 4 wood stakes per bale driven through all layers, full from top of bale to eighteen inches into the ground.
- C. Hay bales which have deteriorated shall be replaced with new materials.
  - D. Erosion and sedimentation controls shall be maintained in a condition which will retain unfiltered water.
  - E. The Contractor shall construct the sedimentation ponds and control devices prior to clearing and grubbing the site to insure complete silt control. When the silt or the debris level is greater than 1 foot above the bottom of the pond, the Contractor shall remove the silt or debris to restore the proper elevation for the bottom of the pond.
  - F. The Contractor shall have all erosion and sedimentation control devices in service and operating properly prior to completion and final acceptance of the contract.
  - G. Two widths of silt fence are available, Type A or C (36" height) and Type B (22" height). In order to determine which to use, the project duration, slope gradient, and slope length must be known (See Table 6-13.1 below). Approved silt fence fabrics are listed in the Georgia Department of Transportation list #36. The manufacturer shall have either an approved color mark yarn in the fabric or label the fabricated silt fence with both the manufacturer and fabric name every 100 feet.

TABLE 6-13.1

<b>Land Slope</b>	<b>Maximum Slope Length Behind Fence</b>
<u>Percent</u>	<u>feet</u>
<2	100
2 to 5	75
5 to 10	50
10 to 20	25
>20	15

All silt fence must meet the minimum standards set forth in Section 171- temporary Silt Fence, of the Department of Transportation, State of Georgia, Standard specification, current edition. See Table 6-13.5 for current Georgia DOT silt fence specifications.

### 3.02 EROSION CONTROL BLANKET INSTALLATION

- A. Prepare a stable and firm soil surface free of rocks and debris. Apply soil amendments as necessary to prepare seedbed. Place fertilizer, water, seed in accordance with manufacture and specification recommendations. Unroll parallel to the primary direction of flow. Ensure that the product maintains intimate contact with the soil over the entire installation. Do not stretch or allow material to bridge over the surface. Staple/stake blanket to soil such that each staple/stake is flush with the underlying soil. Install anchor trenches, seams, and terminal ends as specified.
- B. The Upslope Trench, Seams, and Terminal Ends may be secure by anchor trench, checks, slots, or staples as outlined in Erosion Control technology Council (ECTC) standards for upslope security.

- C. Staple installation shall be at a rate of 1.7 staples per square yard minimum. Sandy or silty soils may require more. Wet installations may require a more density securing.
- D. If seaming method is used seams shall overlap at least 4" and staples must be placed at sufficient spacing to avoid separation.
- E. Staples must be placed at 4"x 4" spacing on check slots and check seams.
- F. Consecutive rolls shall have overlaps of at least 6" and secured with staples every 1foot.

### 3.03 RESPONSIBILITY

- A. The Contractor shall be solely responsible for insuring that no silt or debris leaves the immediate construction site. Any silt or debris that does leave the immediate site shall be cleaned up and the area disturbed shall be returned to its natural state as directed by the Engineer at the Contractor's expense.
- B. The Contractor has the option to submit additional control measures in the form of shop drawings.

Not for Bid

SECTION 02555  
WATER DISTRIBUTION SYSTEM

PART 1 GENERAL

1.01 REFERENCE STANDARDS

A. American Water Works Association (AWWA):

C500 Gate Valves 3" - 48" for Water and Other Liquids

C502 Dry-Barrel Fire Hydrants

C600 Installation of Cast Iron Water Mains

C601 Disinfecting Water Mains

C800 Threads for Underground Service Line Fittings

B. American National Standards Institute (ANSI):

A-21.10 Gray-Iron and Ductile Iron Fittings, 2"-48" for Water and Other liquids

A-21.11 Rubber Gasket Joints for Cast Iron and Ductile Iron Pressure Pipe Fittings

A-21.4 Cement Mortar Lining for Cast Iron and Ductile Iron Pipe and Fittings for Water

A-21.51 Ductile Iron Pipe, Centrifugally Cast in Metal or Sand-Lined Molds, for Water or Other Liquids

B-18.2 Square and Hex-Head Bolts and Screws

C. American Society of Testing and Materials (ASTM):

A-47 Malleable Iron Castings

A-48 Gray Iron Casting

A-88 Seamless Copper Water Tube

A-240 Chromium and Chromium-Nickel Stainless Steel Plate Sheet and Strip for Fusion-Welded Uni-fired Pressure Vessels

A-307 Low Carbon Steel Externally and Internally Threaded Standard Fasteners

D-1784 Rigid Poly (Vinyl chloride) Compounds, and Chlorinated Poly (Vinyl Chloride) Compounds

D-2239 Polyethylene (PE) Plastic Pipe (SDR-PR)

D-2241 Poly Vinyl Chloride (PVC) Plastic Pipe (SDR-PR and Class T)

D-3139 Joints for Plastic Pressure Pipe Using Flexible Elastomeric Seals

D. Rule for Safe Drinking Water, Georgia State EPD: Chapter 391-3-5

#### 1.02 DESCRIPTION

- A. All valves of the same type shall be from a single manufacturer. Parts for valves of the same type and size shall be interchangeable. Spare parts shall be furnished where required in the payment items. Special tools required for repacking or disassembling valves shall be provided.
- B. All valves shall open left (counter-clockwise).

#### 1.03 SUBMITTALS

- A. Six copies of manufacturer's drawings and catalog cuts of the following items shall be submitted for approval of the Design Engineer and the LCPC Inspector:

1. Pipe
2. Fittings
3. Joints and Couplings
4. Hydrants
5. Valves

#### 1.04 PRODUCT DELIVERY, STORAGE AND HANDLING

- A. Materials delivered to site shall be inspected for damage, unloaded and stored with the minimum of handling. Store materials on site in enclosures or under protective coverings. Store plastic piping and rubber gaskets under cover and protect from exposure to direct sunlight. Store materials above ground. Interior of pipe and fittings shall be kept free of dirt and debris.
- B. Pipe, fittings, valves, hydrants and other accessories shall be handled to insure delivery to the point of installation in sound undamaged condition. If coatings or linings of pipe or fittings are damaged, such pipe or fittings shall be removed from the site and new materials furnished. Pipe shall not be dragged. Rubber gaskets that are not installed immediately shall not be left in the sunlight, but shall be stored under cover and protected from exposure to direct sunlight.



## PART 2 - PRODUCTS

### 2.01 POLYVINYL CHLORIDE PIPE (PVC)

- A. IPS Size PVC Pipe: Class 200 SDR 21 - Polyvinyl chloride water main pipe shall conform to Designation ASTM D2241 and shall consist of Type I, Grade 1 PVC compound conforming to ASTM D1784. All pipe shall be Class 200, SDR 21. The standard laying length shall be 20 ft.  $\pm$ 1 inch.
- B. DIP Size PVC Pipe: AWWA C-900-07
1. C-900 polyvinyl chloride water main pipe 4" TO 12" shall conform to Designation ASTM D2241 and shall consist of Type I, Grade 1 PVC compound conforming to ASTM D1784. All pipe larger than 4" to 12" shall meet the requirements of AWWA C900, "Poly Vinyl Chloride (PVC) pressure pipe." All pipe shall be class 200 pipe and shall meet the requirements of DR14. The standard laying length shall be 20 ft.  $\pm$ 1 inch. The FM approved pressure class will be used to determine pressure class.
  2. C-905 polyvinyl chloride water main pipe 14" to 30" shall be manufactured from compounds conforming to PVC cell classification of 12454B as defined in ASTM D-1784. The integral bell joint system meets the requirements of ASTM D-3139 and utilizes an elastomeric seal conforming to ASTM F-477. All pipe shall be class 200 pipe and shall meet the requirements of DR18. The standard laying length shall be 20 ft.  $\pm$ 1 inch.
- C. When DIP size PVC pipe is used two 2" PVC pipe shall be SDR 21, 200 PSI pressure class, iron pipe
- D. Pipe shall have integral bell and spigot joints. Provisions shall be made for contraction and expansion at each joint with an elastomeric ring. Threaded or solvent welded type joints shall not be used. Bell end pipe and couplings with elastomeric gaskets shall meet the requirements of ASTM 3139.
- E. The Contractor shall install a continuous run of 14 gauge copper tracer wire with underground coating above the top of the PVC pipe 12 inches above the pipe but no deeper than 48 inches below finished grade. The tracer wire shall be suitable for detection with metal pipe location equipment.
- F. All water pipe shall be blue in color and labeled "water" every three feet as a minimum.
- G. Pipe shall carry National Sanitation Foundation (NSF) seal and be factory marked with manufacturer's identification, pipe size, material and pressure rating.

## 2.02 DUCTILE IRON PIPE

- A. Ductile iron pipe shall conform to the requirements of ANSI Standard A21.51 and AWWA C151. All pipe shall class 350. Class designations for the various classes of pipe shall be painted on the outside of each joint of pipe. Weights shall be conspicuously painted in white on each joint of pipe after the bituminous coating has hardened.
- B. All joints shall have the same pressure rating as the pipe with which it is used. Joints shall be rubber gasketed push on or mechanical joint. Joints shall meet the requirements of ANSI A21.11 and AWWA C111.
- D. Pipe shall be coated inside and out with one mil. thick bituminous coating conforming to ANSI A21.4 and AWWA C110, C115OR C151. The interior shall be lined with a cement mortar lining conforming to ANSI/AWWA C104/A21.4.

## 2.03 GALVANIZED STEEL PIPE

- A. This pipe and fittings shall conform to the requirements of ASTM A120. The pipe shall be "standard weight", unless otherwise specified.

## 2.04 PLASTIC TUBING

- A. Plastic pipe shall conform to all the requirements of the "Specifications for Polyethylene (PE) Plastic Pipe (ADR-PR)", as they apply to PE 3306 of ASTM D2239.
- B. The hydrostatic design stress shall be 630 psi for water at 23° centigrade (73.4° F) and 500 psi for water at 37.8° C (100° F).
- C. The polyethylene extrusion compound from which the pipe is extruded shall meet the requirements of Type III, Grade 3, Class C material as described in "Specification for Polyethylene Molding and Extrusion Materials", ASTM D1248, except that melt index shall be determined under a higher temperature than any of the conditions as listed in Section 6(b) of "Method of Test for Measuring Flow Rates of Thermoplastics by Extrusion Plastometer", ASTM D1238. The test condition shall be the same as for condition J, except that the temperature shall be 310° C (590° F), with a load of 12-5 kilograms. Under these conditions the resin shall extrude at a maximum rate of 0.25 grams per ten (10) minutes. The pipe shall be homogeneous throughout and free of visible cracks, holes, foreign inclusions or other defects. The pipe shall be uniform in color, capacity, density, and other physical properties.
- D. The size, the type of plastic pipe material, dimension ratio, commercial standards with which the pipe complies, the manufacturer's name and the National Sanitation Foundation (NSF) seal of approval, shall be conspicuously marked on the outside of the pipe at intervals of not more than five (5) feet.

## 2.05 FITTINGS

- A. Ductile iron mechanical joint fittings shall conform to the requirements of ANSI/AWWA C110 and C153. The fittings shall be of the lightest class conforming to the pressure rating of the pipe lines in which they are installed, in no case shall the fittings be lighter than class 200.
- B. Fittings for galvanized steel pipe shall be malleable iron conforming to ANSI B16.3 except the nipples and couplings shall be the same material as the pipe. All fittings shall be hot-dip galvanized in accordance with ASTM A120.
- C. The mechanical joint shall meet requirements of ANSI A21.11 and shall have the same pressure rating as the fitting of which it is a part.
- D. Fittings shall be coated inside and out with one mil. thick bituminous coating conforming to ASNI A21.4.

## 2.06 HYDRANTS

- A. All fire hydrants shall conform to AWWA C502.
- B. All fire hydrants shall have a 6" mechanical joint inlet connection and be equipped with a 5-1/4 inch valve, two 2-1/2 inch hose nozzles and one 4-1/2 inch pumper connection, all with ANSI (National) standard threads. Operating nuts shall be 1-1/2 inch, pentagon type.
- C. All fire hydrants shall be equipped with "O" ring type stem seals.
- D. All fire hydrants shall be designed for 150 psi working pressure and 300 psi test pressure.
- E. All fire hydrants shall be equipped with a 6" gate valve, complying with other sections of the specifications, installed on the fire hydrant lead between the hydrant and the main.
- F. The Contractor shall paint the hydrant with XO-14 Tractor Red (Federal Safety Color) paint.
- G. All fire hydrants shall be designed such that clockwise rotation of the stem closes the valve and counterclockwise rotation opens the valve. Hydrant covers shall have the word "Open" and an arrow showing the proper rotation of the operating nut cast in or permanently attached.
- H. An independent drain shall be provided, completely draining the hydrant after use. The drain shall be activated to the open position by the closing of the hydrant valve. The drain rod shall be easily cleaned. The drain shall have a protective shield integral with the hydrant base to minimize clogging and prevent undermining.
- I. All working parts of the hydrant shall be easily removed for inspection or servicing without digging or the use of hoists or derricks or special tools. The hydrant cover and stand pipe shall be removable without requiring the water to be shut off.

- J. Each fire hydrant shall be equipped with a ground line mounted breakaway flange and cast iron safety stem coupling specially designed so that upon sustaining severe impact the hydrant will shear off at the ground line without loss of water in the main.
- K. All fire hydrants shall be Mueller standard or equal as approved by the Engineer.

## 2.07 METERS

- A. All meters shall be approved first line product of recognized manufacturer and shall be compatible with the meter reading system currently being used by the water system owner and operator.
- B. Meters, meter materials and meter test shall conform to applicable AWWA Specifications and shall meet or exceed current AWWA Specifications.
- C. Each meter shall have manufacturer's serial number on the lid.
- D. All body parts as cases, boxes and lids shall be of bronze composition.
- E. Meters shall be split case, positive displacement type.
- F. The register shall read in U.S. Gallons and shall be hermetically sealed and driven by permanent magnets.

Not for Bid

## 2.08 METER BOXES

- A. The meter box shall be the approved standard product used by the water system owner and operator.
- B. They shall be rectangular and of adequate dimension to accommodate the specified meters.
- C. Boxes shall have cast iron or polyethylene covers labeled "WATER METER".
- D. Boxes for 5/8" by 3/4" meters shall have inside width not less than 10 inches, inside length not less than 15 inches and overall height not less than 12 inches.
- E. Boxes shall be designed and built to withstand traffic loads typical of yard installations.

## 2.09 VALVES

- A. All valves 2" in diameter and smaller shall be constructed of brass or bronze except that the hand wheel which shall be of malleable iron construction with screwed ends. All valves 2-1/2" in diameter and larger shall have flanged ends for interior service and mechanical joints for buried service unless otherwise approved. They shall be iron body, bronze mounted, except that in the smaller sizes the valves may be all bronze.
- B. Gate Valves:
  - 1. Gate valves smaller than three inches shall meet the requirements of Fed. Spec. WW-V-54, Class A, 125 pounds.
  - 2. Gate valves three inches and larger shall have nonrising stems and shall meet the requirements of AWWA Standard C-500. Valves for lighter pressures than the AWWA Standard shall meet the requirements of the above specifications except that the requirements for metal thickness and strengths and structural designs shall be adjusted as required to meet hydrostatic test pressures not less than 150 psi.
  - 3. All gate valves shall have standard stuffing box seals. Bonnet bolts, studs and nuts shall be cadmium plated. Seating devices shall be bronze to iron or bronze to bronze. The glands shall be bronze or bronze bushed. Gland bolts and nuts shall be bronze.
  - 4. All gate valves shall be of the double disc or wedge type. The wedge or disc shall be totally encapsulated in rubber. The sealing rubber shall be permanently bonded to the wedge or disc to meet ASTM tests for rubber metal bond ASTM D249.
  - 5. Valves to have two inches square operating nut, with the exception that gate valves in altitude valves pits shall have hand wheels.

6. Valves buried in ground or located in vaults or structures shall have suitable extensions for socket operation with top of operating nut located two feet below finished grade maximum.
7. Any valve installed in a vault readily accessible for entry shall be equipped with handle wheels in lieu of operating nuts. No hand wheels are allowed in buried valves.

C. Check Valves:

1. Check valves 2" through 24" shall be iron body, bronze mounted swing check valves meeting the requirements of AWWA Standard C508-76.
2. The check valve shall be metal to metal or composite to metal seat construction with flange ends or screw and coupled ends.
3. When check valves are used for open end application to keep surface water from entering a water system drain pipe then the backflow valve shall be Tideflex, Checkmate or equal.

D. Altitude Valves:

1. All altitude valves furnished for use in the systems shall be equipped for showing at all times the position of the valve. Said altitude valves shall be of the size specified on the drawings and suitable for the use intended.
2. The Contractor shall supply the services of a qualified manufacturer's representative to check and calibrate each altitude valve installation for proper working pressure and sequence.

E. Air Release Valves

1. Air release valve shall have all bronze body and bonnet. They shall be the direct acting type.
2. Valves shall be hydrostatically tested to at least 150 psi.
3. The valve shall have stainless steel floats and an internal coating with rust inhibitors.

## 2.10 BACKFLOW PREVENTERS

- A. The backflow preventers used shall be those specifically designed for use in connections when the danger from backflow presents a health hazard.
- B. All backflow preventers shall be of the reduced pressure type.
- C. Backflow preventers 3/4" to 2" shall be Hersey, Model FRPII or equal meeting or exceeding the following specifications:

Mainline Case - Bronze  
Working Parts - Bronze & Stainless Steel  
Springs - Stainless Steel  
Diaphragms - Buna N and Mylar

Valve disc - Silicone Rubber  
O Ring - Buna N  
Check Valve Enclosure - Glass Reinforced Plastic  
Maximum Rated Working Pressure - 150 psi  
Temp. Range - 33° - 210°F

- D. Backflow Preventers 2½" to 10" shall be Model 6CM or equal meeting or exceeding the following specifications:

Body 8"-10"- Hot Dipped Galvanized or Epoxy Coating  
Body 2½"-6" - Bronze  
Working Parts - Bronze & Stainless Steel  
Springs 2½"-6"- Stainless Steel  
Springs 8"-10"- Vinyl Coated Carbon Steel  
Diaphragms - Reinforced Elastomer  
Valve Disc - Silicone Rubber  
Maximum Rated Working Pressure - 175 psi  
Temp. Range - 33° - 140°F

- E. Backflow preventers larger than 10" shall be designed for conditions that do present a health hazard. It shall be the reduced pressure type and depending on the application, may require detection of leaks or unauthorized use. Detectors above 10" shall be submitted for approval. The submittal shall include complete shop drawings. The submittal will be reviewed based on the product's ability to meet the needs of the project and the Owner.

### PART 3 - EXECUTION

- A. All valves shall be carefully mounted in their respective positions free from distortion and strain. All valves shall be properly packed and left in satisfactory operating condition at the completion of the project.
- B. Valve box, cover and concrete pad shall be installed with each valve as shown in miscellaneous details.

#### 3.01 PIPE INSTALLATION

- A. PVC pipe shall be installed in accordance with the Uni-Bell Plastic Pipe Association guide for installation of polyvinyl chloride plastic pressure pipe for municipal water main distribution system and the printed recommendations of the manufacturer.
- B. Ductile iron pipe shall be installed in accordance with AWWA C600.
- C. Pipe line alignment and gradient shall be straight, or shall follow true curves as near as practicable. Curvature in pipe lines, where required, shall be well within the allowable laying radius, horizontal and vertical.
- D. Excavation, cleaning, laying, jointing and backfilling shall follow as closely as is possible so as to progress the work. In no case shall pipe be left in the trench overnight without completing the jointing. The completed pipe line shall not be left exposed in the trench unnecessarily, and the Contractor shall backfill and compact the trench as soon as is possible after laying and jointing is completed. Each day at the close of work, and at all times when laying is not in progress, the exposed end of the pipe line in the trench shall be closed with a head or barrier of wood or metal. If

at any time it becomes necessary to cover the end of any uncompleted pipe line with backfill, the end of that pipe shall be closed with a mechanical joint plug.

- E. The Contractor shall keep exposed ends of pipe properly plugged during laying to prevent dirt and other materials from entering the line, and shall also, before the system is accepted, thoroughly clean all lines.
- F. Thrust Blocks (Reaction Blocking) shall be provided as specified AWWA C600. All exposed pipes, valves, hydrants, etc., shall be securely strapped and all ends and bends braced.
- G. Other means of pipe restraining in addition to thrust blocking shall include "mega lug" utilization and all threads bolted through fittings in accordance with AWWA C600. Thrust blocking may not be eliminated with the use of joint restraint.
- H. Mechanical joints shall be made only by experienced mechanics. Sockets and spigots shall be washed with soapy water before slipping gland and gasket over spigot. The spigot shall be inserted in the socket full depth. The gasket shall be brushed with soapy water, and pushed into position making sure the gasket is evenly seated in the socket. The gland shall then be properly positioned for compressing the gasket. All bolts and nuts shall be tightened with a torque wrench to a uniform, permanent tightness. Bolts shall be tightened alternately 180 degrees apart. Sockets, spigots, glands and bolts shall be kept clean and wet with soapy water until each joint is completed.
- I. All water distribution mains shall have a minimum 36" of cover.

### 3.02 FIRE HYDRANT INSTALLATION

- A. All fire hydrants shall have 36" minimum pipe cover provided for the branch supply line.
- B. Each fire hydrant shall be set on a stable foundation at least 18 inches square and 6 inches thick and shall be blocked against the end of the trench with concrete and anchored.
- C. Hydrant drainage shall be provided by installing around the hydrant at least 7 cubic feet of gravel or crushed stone below the top of the hydrant supply pipe.
- D. The barrel of the fire hydrant shall be set plumb (perpendicular to the ground) with the lowest discharge outlet at least fifteen (15) inches high but no higher than 24 inches above finished grade. No fire hydrant shall be installed within 10 feet of any private driveway. Hydrants shall be located no closer than 5 feet of a curbing and no further than 12 feet of the curbing.
- E. Immediately before installation of a hydrant, the following operations shall be performed:
  - 1. The hydrant shall be thoroughly inspected.
  - 2. The hydrant interior shall be thoroughly cleaned.
  - 3. The hydrant shall be opened and closed to determine that all parts are in proper working order, with valves seating properly and the drain valve operating freely.



### 3.03 HYDROSTATIC TEST

- A. Upon completion of backfilling operations and not less than seven (7) days after the last concrete blocking anchor has been poured, the pipe system shall be subject to hydrostatic test.
- B. The system shall be filled with water and all air expelled.
- C. The Contractor shall pressurize the system to 150 pounds per square inch at the highest point in the system.
- D. The test pressure shall be maintained for two hours.
- E. If the pressure cannot be maintained, the cause shall be determined, corrected and test repeated until successful.

### 3.04 LEAKAGE TEST

- A. Following the pressure test, the system shall be subject to a leakage test.
- B. Leakage shall be defined as the quantity of water that must be supplied into the pipe to maintain the design working pressure after all air in the pipe line has been expelled and the pipe has been filled with water.

- C. Leakage shall not exceed the quantity determined by the formula given below:

$$L = \frac{ND(\text{Square Root of } P)}{7400}$$

WHERE L = allowable leakage in gallon/hr.  
N = number of joints in pipe line  
D = nominal diameter of the pipe inches  
P = average test pressure during leakage test in psig

- D. If leakage exceeds the allowable rate, leaks shall be found and repaired and the test repeated until successful.

### 3.05 DISINFECTION

- A. Water mains and accessories shall be disinfected in accordance with "Rules for Safe Drinking Water" as published by the Georgia Environmental Protection Division.
- B. The mains shall be flushed into the storm drainage system before disinfecting by maintaining a velocity of at least 2.5 feet per second for a period of ten minutes.
- C. The continuous feed method may be used for any size main or system where satisfactory quantity and quality water is available. The tablet method shall not be acceptable.
- E. Following disinfection of the water system, the system shall be flushed until chlorine concentration is less than 1 milligram per liter. Flushing shall not allow chlorinated water to be discharged into the storm sewer system without first allowing the chlorine

in the system to dissipate. The contractor Shall use a Pollard Water LPD-250 or equal equipment along with LPD-Chlor tablets (Sodium Sulfate or Ascorbic Acid) to de-chlorinate the water using 1 tablet per 2000 gallons of water minimum prior to flushing, then after adequate testing, discharge the de-chlorinated water to the storm sewer system or onto the land surface. During the de-chlorination flushing the flow through the LPD 250 will be maintained at between 200 and 1200 GPM. No flows for de-chlorination or flushing will not be allowed outside this flow specification. The contractor may apply to the owner of the sanitary sewer system to obtain permission to discharge the chlorinated water into the sanitary sewer system for a fee. The contractor shall be charged at the going rate per gallon for treating the water discharged to the sanitary sewer system.

E. Bacteriologic Tests:

1. Tests shall be performed to detect the presence of coliform organisms on samples taken from the end farthest from the point at which chlorine was introduced into the system and at 1000 ft. intervals.
2. The bacteriological sample shall meet the requirements established by EPD for suitable disinfection for human consumption.
3. If unsatisfactory samples are produced, disinfection shall be repeated until samples are satisfactory.

Not for Bid

SECTION 02560  
NON-POTABLE REUSE WATER SYSTEM

PART 1 GENERAL

1.01 REFERENCE STANDARDS

A. American Water Works Association (AWWA):

C500 Gate Valves 3" - 48" for Water and Other Liquids

C502 Dry-Barrel Fire Hydrants

C600 Installation of Cast Iron Water Mains

C601 Disinfecting Water Mains

C800 Threads for Underground Service Line Fittings

B. American National Standards Institute (ANSI):

A-21.10 Gray-Iron and Ductile Iron Fittings, 2"-48" for Water and Other liquids

A-21.11 Rubber Gasket Joints for Cast Iron and Ductile Iron Pressure Pipe Fittings

A-21.4 Cement Mortar Lining for Cast Iron and Ductile Iron Pipe and Fittings for Water

A-21.51 Ductile Iron Pipe, Centrifugally Cast in Metal or Sand-Lined Molds, for Water or Other Liquids

B-18.2 Square and Hex-Head Bolts and Screws

C. American Society of Testing and Materials (ASTM):

A-47 Malleable Iron Castings

A-48 Gray Iron Casting

A-88 Seamless Copper Water Tube

A-240 Chromium and Chromium-Nickel Stainless Steel Plate Sheet and Strip for Fusion-Welded Uni-fired Pressure Vessels

A-307 Low Carbon Steel Externally and Internally Threaded Standard Fasteners

D-1784 Rigid Poly (Vinyl chloride) Compounds, and Chlorinated Poly (Vinyl Chloride) Compounds

D-2239 Polyethylene (PE) Plastic Pipe (SDR-PR)

D-2241 Poly Vinyl Chloride (PVC) Plastic Pipe (SDR-PR and Class T)

D-3139 Joints for Plastic Pressure Pipe Using Flexible Elastomeric Seals

D. Rule for Safe Drinking Water, Georgia State EPD: Chapter 391-3-5

#### 1.02 DESCRIPTION

- A. All valves of the same type shall be from a single manufacturer. Parts for valves of the same type and size shall be interchangeable. Spare parts shall be furnished where required in the payment items. Special tools required for repacking or disassembling valves shall be provided.
- B. All valves shall open left (counter-clockwise).
- C. All pipe and fittings shall be Pantone 522 or 512 or a shade of purple acceptable to the City of Hinesville.
- D. No NPRL shall be less than 2”.

#### 1.03 SUBMITTALS

- A. Six copies of manufacturer's drawings and catalog cuts of the following items shall be submitted for approval of the Design Engineer:
  - 1. Pipe
  - 2. Fittings
  - 3. Joints and Couplings
  - 4. Hydrants
  - 5. Valves

#### 1.04 PRODUCT DELIVERY, STORAGE AND HANDLING

- A. Materials delivered to site shall be inspected for damage, unloaded and stored with the minimum of handling. Store materials on site in enclosures or under protective coverings. Store plastic piping and rubber gaskets under cover and protect from exposure to direct sunlight. Store materials above ground. Interior of pipe and fittings shall be kept free of dirt and debris. Pipe with faded color not meeting acceptable color requirements will not be installed.
- B. Pipe, fittings, valves, hydrants and other accessories shall be handled to insure delivery to the point of installation in sound undamaged condition. If coatings or linings of pipe or fittings are damaged, such pipe or fittings shall be removed from the site and new materials furnished. Pipe shall not be dragged. Rubber gaskets that are not installed immediately shall not be left in the sunlight, but shall be stored under cover and protected from exposure to direct sunlight.

## PART 2 - PRODUCTS

### 2.01 POLYVINYL CHLORIDE PIPE (PVC)

- A. IPS Size PVC Pipe: Class 200 SDR 21 - Polyvinyl chloride water main pipe shall conform to Designation ASTM D2241 and shall consist of Type I, Grade 1 PVC compound conforming to ASTM D1784. All pipe shall be Class 200, SDR 21. The standard laying length shall be 20 ft.  $\pm 1$  inch.
- B. DIP Size PVC Pipe: AWWA C-900-07
  - 1. C-900 polyvinyl chloride water main pipe 4" TO 12" shall conform to Designation ASTM D2241 and shall consist of Type I, Grade 1 PVC compound conforming to ASTM D1784. All pipe larger than 4" to 12" shall meet the requirements of AWWA C900, "Poly Vinyl Chloride (PVC) pressure pipe." All pipe shall be class 200 pipe and shall meet the requirements of DR14. The standard laying length shall be 20 ft.  $\pm 1$  inch. The FM approved pressure class will be used to determine pressure class.
  - 2. C-905 polyvinyl chloride water main pipe 14" to 30" shall be manufactured from compounds conforming to PVC cell classification of 12454B as defined in ASTM D-1784. The integral bell joint system meets the requirements of ASTM D-3139 and utilizes an elastomeric seal conforming to ASTM F-477. All pipe shall be class 200 pipe and shall meet the requirements of DR18. The standard laying length shall be 20 ft.  $\pm 1$  inch. The FM approved pressure class will be used to determine pressure class.
- C. When DIP size PVC pipe is used two 2" PVC pipe shall be SDR 21, 200 PSI pressure class, iron pipe
- D. Pipe shall have integral bell and spigot joints. Provisions shall be made for contraction and expansion at each joint with an elastomeric ring. Threaded or solvent welded type joints shall not be used. Bell end pipe and couplings with elastomeric gaskets shall meet the requirements of ASTM 3139.
- E. The Contractor shall install a continuous run of 14 gauge copper tracer wire with underground coating above the top of the PVC pipe 12 inches above the pipe but no deeper than 48 inches below finished grade. The tracer wire shall be suitable for detection with metal pipe location equipment.
- F. Pipe shall carry National Sanitation Foundation (NSF) seal and be factory marked with manufacturer's identification, pipe size, material and pressure rating.

### 2.02 FUSIBLE POLYVINYLCHLORIDE PRESSURE PIPE FOR NON-POTABLE WATER

- A. Fusible polyvinylchloride plastic material for pipe shall conform to AWWA C900 or C905, ASTM D1784, and cell classification 12454. Pipe shall be in accordance with ASTM D2241 for IPS standard dimensions as indicated in these specifications. Compound formulation shall be in accordance with PPI TR-2/2006. All pipe shall be class 200 pipe and shall meet the requirements of DR14.
- B. Pipe shall be manufactured with 100% virgin resin.

- C. Fusible polyvinylchloride pipe shall be extruded with plain ends. The ends shall be square to the pipe and free of any bevel or chamfer. There shall be no bell or gasket of any kind incorporated into the pipe.
- D. Fusible polyvinylchloride pipe shall be manufactured in a standard 20', 30' or 40' nominal lengths.
- E. Fusible polyvinylchloride pipe shall be purple in color.
- F. Pipe shall be marked per AWWA C900 or AWWA C905, and shall include as a minimum:
  - 1. Nominal size
  - 2. PVC
  - 3. Dimension Ratio, Standard Dimension Ratio or Schedule
  - 4. AWWA pressure class or rating
  - 5. AWWA Standard designation number
  - 6. "Not for Potable Use" designation
  - 7. Extrusion production-record code
  - 8. Trademark or trade name
  - 9. Cell classification 12454 and/or PVC material code 1120 may also be included.
- G. Pipe shall be homogeneous throughout and be free of visible cracks, holes, foreign material, blisters, or other deleterious faults.

### 2.03 FUSION JOINTS

- A. Unless otherwise specified, fusible polyvinylchloride pipe lengths shall be assembled in the field with butt-fused joints. The Contractor shall follow the pipe supplier's written instructions for this procedure. Joint strength shall be equal to the pipe as demonstrated by testing requirements. All fusion joints shall be completed as described in this specification.

### 2.04 DUCTILE IRON PIPE

- A. Ductile iron pipe shall conform with the requirements of ANSI Standard A21.51 and shall be class 350 pipe. Class designations for the various classes of pipe shall be painted on the outside of each joint of pipe. Weights shall be conspicuously painted in white on each joint of pipe after the bituminous coating has hardened.
- B. All joints shall have the same pressure rating as the pipe with which it is used. Joints shall be rubber gasketed push on or mechanical joint. Joints shall meet the requirements of ANSI A21.11.
- C. Pipe shall be coated inside and out with one mil. thick bituminous coating conforming to ANSI A21.4 and AWWA C110, C115OR C151. Pipe shall have a ceramic epoxy lining comparable to Protecto 401 lining or equal.
- D. All ductile iron pipe shall be coated with a sealer to prevent bleeding of bituminous coating through the paint then painted to the following specifications.
  - 1. Paint shall be Pantone 522 or 512 or a shade of purple approved by the City.

2. Paint shall be manufactured in Induron, Koppers or Tnemec
3. Dry film thickness shall be 1-2 mils per coat.
4. Surface shall be clean and dry.
5. Coverage shall be 600 SF/gallon.
6. Apply coating in strict accordance with manufacturer's requirements.

## 2.05 PLASTIC TUBING

- A. Plastic pipe shall conform to all the requirements of the "Specifications for Polyethylene (PE) Plastic Pipe (ADR-PR)", as they apply to PE 3306 of ASTM D2239 and shall be purple in color.
- B. The hydrostatic design stress shall be 630 psi for water at 23° centigrade (73.4° F) and 500 psi for water at 37.8° C (100° F).
- C. The polyethylene extrusion compound from which the pipe is extruded shall meet the requirements of Type III, Grade 3, Class C material as described in "Specification for Polyethylene Molding and Extrusion Materials", ASTM D1248, except that melt index shall be determined under a higher temperature than any of the conditions as listed in Section 6(b) of "Method of Test for Measuring Flow Rates of Thermoplastics by Extrusion Plastometer", ASTM D1238. The test condition shall be the same as for condition J, except that the temperature shall be 310° C (590° F), with a load of 12-5 kilograms. Under these conditions the resin shall extrude at a maximum rate of 0.25 grams per ten (10) minutes. The pipe shall be homogeneous throughout and free of visible cracks, holes, foreign inclusions or other defects. The pipe shall be uniform in color, capacity, density, and other physical properties.
- D. The size, the type of plastic pipe material, dimension ratio, commercial standards with which the pipe complies, the manufacturer's name and the National Sanitation Foundation (NSF) seal of approval, shall be conspicuously marked on the outside of the pipe at intervals of not more than five (5) feet.

## 2.06 FITTINGS

- A. Mechanical fittings and restrained fittings shall conform to ANSI A21.53/AWWA C153 or A21.10/AWWA C110.
- B. Flanged fittings shall conform to ANSI A21.10/AWWA C110. The AWWA C110 fitting flanges shall have facing and drilling which match AWWA C115 thread-on flanges which also match ANSI B16.1 class 125 flanges except where class 250 are specifically noted.
- C. Fittings shall be available in 4" through 24" sizes and shall be cast from ductile iron in accordance with ANSI/AWWA C153/A21.53 with mechanical joint bells or push-on joint bells. Fittings shall be listed by an approved certifying agency as conforming to the requirements of ANSI/NSF 61. The working pressure shall be 350 PSI. Fittings shall be made in the USA. No foreign fittings shall be allowed. Ductile iron fittings shall be coated with 6-8 mil. nominal thickness, fusion bonded epoxy conforming to the requirements of ANSI/AWWA C550 and C116/A21.16.
- D. Fittings shall be coated outside with one mil. thick bituminous coating conforming to ANSI A21.4 and inside with ceramic epoxy lining comparable to Protecto 401 lining or equal.

## 2.07 HYDRANTS

- A. All fire hydrants shall conform to AWWA C502.
  - B. All fire hydrants shall have a 6" mechanical joint inlet connection and be equipped with a 5-1/4 inch valve, two 2-1/2 inch hose nozzles and one 4-1/2 inch pumper connection, all with ANSI (National) standard threads. Operating nuts shall be 1-1/2 inch, pentagon type.
  - C. All fire hydrants shall be equipped with "O" ring type stem seals.
  - D. All fire hydrants shall be designed for 150 psi working pressure and 300 psi test pressure.
  - E. All fire hydrants shall be equipped with a 6" gate valve, complying with other sections of the specifications, installed on the fire hydrant lead between the hydrant and the main.
  - F. The Contractor shall paint the hydrant with Pantone 522 or 512 or a shade of purple acceptable to the City of Hinesville.
  - G. All fire hydrants shall be designed such that clockwise rotation of the stem closes the valve and counterclockwise rotation opens the valve. Hydrant covers shall have the word "Open" and an arrow showing the proper rotation of the operating nut cast in or permanently attached.
  - H. An independent drain shall be provided, completely draining the hydrant after use. The drain shall be activated to the open position by the closing of the hydrant valve. The drain rod shall be easily cleaned. The drain shall have a protective shield integral with the hydrant base to minimize clogging and prevent undermining.
  - I. All working parts of the hydrant shall be easily removed for inspection or servicing without digging or the use of hoists or derricks or special tools. The hydrant cover and stand pipe shall be removable without requiring the water to be shut off.
  - J. Each fire hydrant shall be equipped with a ground line mounted breakaway flange and cast iron safety stem coupling specially designed so that upon sustaining severe impact the hydrant will shear off at the ground line without loss of water in the main.
  - K. All fire hydrants shall be Mueller standard or equal as approved by the Engineer
- 2.07 METERS

- A. All meters shall be approved first line product of recognized manufacturer and shall be compatible with the meter reading system currently being used by the Owner.
- B. Meters, meter materials and meter test shall conform to applicable AWWA Specifications and shall meet or exceed current AWWA Specifications.
- C. Each meter shall have manufacturers serial number on the lid.
- D. All body parts as cases, boxes and lids shall be of bronze composition.
- E. Meters shall be split case, positive displacement type.



- F. The register shall read in U.S. Gallons and shall be hermetically sealed and driven by permanent magnets.

## 2.08 METER BOXES

- A. The meter box shall be the approved standard product used by the City of Hinesville. Painted in accordance with NPRL standards and marked as "REUSE WATER, NOT FOR HUMAN CONSUMPTION" on the lid.
- B. They shall be rectangular and of adequate dimension to accommodate the specified meters.
- C. Boxes shall have cast iron or heavy plastic covers labeled "REUSE WATER, NOT FOR HUMAN CONSUMPTION".
- D. Boxes for 5/8" by 3/4" meters shall have inside width not less than 10 inches, inside length not less than 15 inches and overall height not less than 12 inches.
- E. Boxes shall be designed and built to withstand traffic loads typical of yard installations.

## 2.09 VALVES

- A. All valves 2" in diameter and smaller shall be constructed of brass or bronze except that the hand wheel which shall be of malleable iron construction with screwed ends. All valves 2-1/2" in diameter and larger shall have flanged ends for interior service and mechanical joints for buried service unless otherwise approved. They shall be iron body, bronze mounted, except that in the smaller sizes the valves may be all bronze.

### B. Gate Valves:

1. Gate valves shall conform to AWWA C500-86 for double-disc gate valves or AWWA C509-87 for resilient-seated gate valves, and shall be as manufactured by American Flow Control, U.S. Pipe, Mueller or approved equal. Gate valves shall be hand operated, non-rising stem, with ductile iron bodies, and adapted for joints as indicated in the approved design drawings, or as directed.
2. All gate valves shall open by turning the operating nut to the left (counter clockwise).
3. Gate valves shall only be used in sizes 2" through 10".

### C. Butterfly Valves:

1. Butterfly valves shall conform to the requirements of AWWA C504-87, and shall be as manufactured by American Flow Control, Henry Pratt, Allis-Chalmers, or approved equal.
2. Butterfly valves shall be hand operated with ductile iron bodies, and adapted for joints as indicated in the approved design drawings, or as directed.
3. All butterfly valves shall open by turning the operating nut to the left (counter clockwise). Butterfly valves shall only be used in sizes 12" and larger.

D. Tapping Sleeves and Valves:

1. The Contractor shall furnish and install tapping sleeves and valves suitable for connection to the existing NPRLs at locations indicated on the approved plans, or as directed. The Contractor shall also provide the tapping machine and competent supervision for the making of taps. It is the Contractor's responsibility to verify the type, size and O.D. and class of the existing pipe before ordering the tapping sleeve and valve.
2. Prior to making the tap, the Contractor, in the presence of the City Engineer/Inspector, shall hydrostatically pressure test the complete tapping sleeve and valve installation at a test pressure of 150 PSI, or 50 PSI over the existing system static pressure, whichever is greater, **(PNEUMATIC, OR AIR-PRESSURE TESTING IS PROHIBITED)**. The Contractor shall properly support the tapping sleeve and valve using bricks, blocks, wedges, or other substantial supporting materials, which will not permit the tapping valve or tapping machine to transfer any downward rotational force to the tapping sleeve. This support shall be provided before mounting the tapping machine.
3. Tapping sleeves shall be ductile iron with mechanical joint ends as manufactured by American Flow Control, Mueller, or approved equal. Outlets shall be sized to permit a tap to be made using a full-size shell cutter. The existing pipe shall be thoroughly cleaned prior to the installation of the tapping sleeve. **THE USE OF STRAP-TYPE TAPPING SADDLES FOR TAPS LARGER THAN 2" IS NOT PERMITTED.**
4. Tapping valves shall conform to the requirements for gate valves hereinbefore stipulated, except for any modifications necessary to permit the use of full size shell cutters. If of the double-disc variety, tapping valves 16" and larger shall be installed in a horizontal configuration, and shall be supplied with a by-pass. Resilient seated tapping valves 16" and larger may be supplied without the by-pass. When using resilient seated gate valves for making taps 16" and larger, it is the Contractor's responsibility to determine the finished depth of cover that shall remain over the operating nut of the valve after installation. If finished depth of cover in a standard vertical configuration is less than 2 feet, then the tapping valve shall be supplied in a horizontal configuration with differential operator.

E. Backtaps

**BACKTAPS SHALL NOT BE PERMITTED UNLESS SPECIFICALLY AUTHORIZED BY THE CITY OF HINESVILLE. ANY SAID AUTHORIZED BACKTAPS SHALL BE CONSTRUCTED USING M.J. FITTINGS AND "MEGALUG" RETAINER GLANDS, AND SINGLE JOINTS OF PIPE. THREADED ROD SHALL ONLY BE PERMITTED FROM THE STEEL CASING TO THE FIRST FITTING, AND SHALL BE WELDED FOR A MINIMUM OF 8-INCHES ON EACH ROD ALONGSIDE THE CASING. WELDING OF I-BOLTS DIRECTLY TO THE CASING FOR THE PURPOSE OF INSTALLING THREADED ROD IS NOT PERMITTED.**

F. Accessory Equipment

All valves, which are to be buried in the ground, shall be provided with a valve and box cover. The Contractor shall provide suitable, permanently installed valve stem extensions and guides, which have been approved by the City of Hinesville prior to fabrication and placement.

G. Valve Markers

Valve markers shall be furnished and installed with each valve on the proposed project. The markers shall be white drivable markers #CIB-380 seventy-eight (78") inches long (manufactured by Carsonite International) and extend to the valve. The markers shall be installed as close to the valve as possible, facing the street. The marker is not to protrude the finished surface grade more than three (3') feet and no less than eighteen (18") inches above the finished grade. Each marker must be labeled on both sides in accordance with the attached detail.

H. Future Stubs

All stubs for future use must be marked with a White Drivable Marker #SNFB096-01 eight (8') feet long (manufactured by Carsonite International) and extend to the pipe. The markers shall be installed facing the street. The marker is not to protrude the finished grade less than two (2') feet and not to exceed three (3') feet. Each marker must be labeled on both sides as per the attached detail.

## 2.10 BACKFLOW PREVENTERS

- A. The backflow preventers used shall be those specifically designed for use in connections when the danger from backflow presents a health hazard.
- B. All backflow preventers shall be of the reduced pressure type for normal use and double check for fire protection.
- A. Backflow preventers 3/4" to 2" shall be Watts,  
1/2" to 2" Double Check shall be Watts Series 007  
1/2" to 2" Reduced Pressure shall be Watts Series 009  
Larger than 2" Double Check shall be Watts 757DCDA  
Larger than 2" Reduced Pressure shall be Watts 994RPDA

or equal meeting or exceeding the following specifications:

Mainline Case - Bronze  
Working Parts - Bronze & Stainless Steel  
Springs - Stainless Steel  
Diaphragms - Buna N and Mylar  
Valve disc - Silicone Rubber  
O Ring - Buna N  
Check Valve Enclosure - Glass Reinforced Plastic  
Maximum Rated Working Pressure - 150 psi  
Temp. Range - 33° - 210°F

- D. Backflow Preventers 2 1/2" and larger shall be or equal meeting or exceeding the following specifications:

Body 2½"-6" - Stainless Steel  
Working Parts - Bronze & Stainless Steel  
Springs 2½"-6"- Stainless Steel  
Springs 8"-10"- Vinyl Coated Carbon Steel  
Diaphragms - Reinforced Elastomer  
Valve Disc - Silicone Rubber  
Maximum Rated Working Pressure - 175 psi  
Temp. Range - 33° - 140°F

- E. Backflow preventers larger than 6" shall be designed for conditions that do present a health hazard. It shall be the reduced pressure type and depending on the application, may require detection of leaks or unauthorized use. Detectors above 6" shall be submitted for approval. The submittal shall include complete shop drawings. The submittal will be reviewed based on the product's ability to meet the needs of the project and the Owner.

### PART 3 - EXECUTION

- A. All valves shall be carefully mounted in their respective positions free from distortion and strain. All valves shall be properly packed and left in satisfactory operating condition at the completion of the project.
- B. Valve box and cover shall be installed with each valve as shown in miscellaneous details.

#### 3.01 PIPE INSTALLATION

- A. PVC pipe shall be installed in accordance with the Uni-Bell Plastic Pipe Association guide for installation of polyvinyl chloride plastic pressure pipe for municipal water main distribution system and the printed recommendations of the manufacturer.
- B. Ductile iron pipe shall be installed in accordance with AWWA C600.
- C. Pipe line alignment and gradient shall be straight, or shall follow true curves as near as practicable. Curvature in pipe lines, where required, shall be well within the allowable laying radius, horizontal and vertical.
- D. Excavation, cleaning, laying, jointing and backfilling shall follow as closely as is possible so as to progress the work. In no case shall pipe be left in the trench overnight without completing the jointing. The completed pipe line shall not be left exposed in the trench unnecessarily, and the Contractor shall backfill and compact the trench as soon as is possible after laying and jointing is completed. Each day at the close of work, and at all times when laying is not in progress, the exposed end of the pipe line in the trench shall be closed with a head or barrier of wood or metal. If at any time it becomes necessary to cover the end of any uncompleted pipe line with backfill, the end of that pipe shall be closed with a mechanical joint plug.
- E. The Contractor shall keep exposed ends of pipe properly plugged during laying to prevent dirt and other materials from entering the line, and shall also, before the system is accepted, thoroughly clean all lines.

- F. Thrust Blocks (Reaction Blocking) shall be provided as specified AWWA C600. All exposed pipes, valves, hydrants, etc., shall be securely strapped and all ends and bends braced.
- G. Other means of pipe restraining shall include "mega lug" utilization and all threads bolted through fittings in accordance with AWWA C600.
- H. Mechanical joints shall be made only by experienced mechanics. Sockets and spigots shall be washed with soapy water before slipping gland and gasket over spigot. The spigot shall be inserted in the socket full depth. The gasket shall be brushed with soapy water, and pushed into position making sure the gasket is evenly seated in the socket. The gland shall then be properly positioned for compressing the gasket. All bolts and nuts shall be tightened with a torque wrench to a uniform, permanent tightness. Bolts shall be tightened alternately 180 degrees apart. Sockets, spigots, glands and bolts shall be kept clean and wet with soapy water until each joint is completed.
- I. All water distribution mains shall have a minimum 48" of cover.

### 3.02 FUSION PROCESS

#### A. GENERAL

1. Fusible polyvinylchloride pipe will be handled in a safe and non-destructive manner before, during, and after the fusion process and in accordance with this specification and pipe supplier's recommendations.
2. Fusible polyvinylchloride pipe will be fused by qualified fusion technicians, as documented by the pipe supplier. Training records for qualified fusion technicians shall be available to Owner or Engineer upon request.
3. Each joint fusion shall be recorded and logged by an electronic monitoring device (data logger) affixed to the fusion machine. Joint data shall be submitted as part of the As-Recorded information, in accordance with this specification.
4. This fusible polyvinylchloride pipe will be installed in a manner so as not to exceed the recommended bending radius.
5. Where fusible polyvinylchloride pipe is installed by pulling in tension, the recommended Safe Pulling Force, according to the pipe supplier, will not be exceeded.
6. Only appropriately sized, and outfitted fusion machines that have been approved by the pipe supplier shall be used for the fusion process. Fusion machines must incorporate the following properties, including the following elements:
  - a) HEAT PLATE – Heat plates shall be in good condition with no deep gouges or scratches within the pipe circle being fused. Plates shall be clean and free of any contamination. Heater controls shall properly function, and cord and plug shall be in good condition. The appropriately sized heat plate shall be capable of maintaining a uniform and consistent heat profile and temperature for the size of pipe being fused, per the pipe supplier's recommendations.

- b) CARRIAGE – Carriage shall travel smoothly with no binding at less than 50 psi. Jaws shall be in good condition with proper inserts for the pipe size being fused. Insert pins shall be installed with no interference to carriage travel.
  - c) GENERAL MACHINE – Overview of machine body shall yield no obvious defects, missing parts, or potential safety issues during fusion.
  - d) DATALOGGER - The current version of the pipe supplier’s recommended and compatible software shall be used. Protective case shall be utilized for the hand held wireless portion of the unit. Datalogger operations and maintenance manual shall be with the unit at all times. If fusing for extended periods of time, an independent 110V power source shall be available to extend battery life.
7. Other equipment specifically required for the fusion process shall include the following:
- a) Pipe rollers shall be used for support of pipe to either side of the machine.
  - b) A weather protection canopy that allows full machine motion of the heat plate, fusion assembly and carriage shall be provided for fusion in inclement and/or windy weather.
  - c) Fusion machine operations and maintenance manual shall be kept with the fusion machine at all times.
  - d) Facing blades specifically designed for cutting fusible polyvinylchloride pipe.

#### B. JOINT RECORDING

Each fusion joint shall be recorded and logged by an electronic monitoring device (data logger) connected to the fusion machine. The fusion data logging and joint report shall be generated by software developed specifically for the butt-fusion of thermoplastic pipe. The software shall register and/or record the parameters required by the manufacturer and these specifications. Data not logged by the data logger shall be logged manually and be included in the Fusion Technician’s joint report.

### 3.03 HYDROSTATIC TEST

- A. Upon completion of backfilling operations and not less than seven (7) days after the last concrete blocking anchor has been poured, the pipe system shall be subject to hydrostatic test.
- B. The system shall be filled with water and all air expelled.
- C. The Contractor shall pressurize the system to 150 pounds per square inch at the highest point in the system.
- D. The test pressure shall be maintained for two hours.
- E. If the pressure cannot be maintained, the cause shall be determined, corrected and test repeated until successful.

### 3.04 LEAKAGE TEST

- A. Following the pressure test, the system shall be subject to a leakage test.
- B. Leakage shall be defined as the quantity of water that must be supplied into the pipe to maintain the design working pressure after all air in the pipe line has been expelled and the pipe has been filled with water.
- C. Leakage shall not exceed the quantity determined by the formula given below:

$$L = \frac{ND(\text{Square Root of } P)}{7400}$$

WHERE L = allowable leakage in gallon/hr.  
N = number of joints in pipe line  
D = nominal diameter of the pipe inches  
P = average test pressure during leakage test in psig

- D. If leakage exceeds the allowable rate, leaks shall be found and repaired and the test repeated until successful.

### 3.05 DISINFECTION

- A. Non-potable reuse water lines (NPRL) and accessories shall be disinfected in accordance with "Rules for Safe Drinking Water" as published by the Georgia Environmental Protection Division.
- B. The mains shall be flushed before disinfecting by maintaining a velocity of at least 2.5 feet per second for a period of ten minutes.
- C. The continuous feed method may be used for any size main or system where satisfactory quantity and quality water is available. The tablet method shall not be acceptable.
- D. Following disinfection, the system shall be flushed until chlorine concentration is less than 1 milligram per liter.
- E. Bacteriologic Tests:
  - 1. Tests shall be performed to detect the presence of coliform organisms on samples taken from the end farthest from the point at which chlorine was introduced into the system and at 1000 ft. intervals.
  - 2. If unsatisfactory samples are produced, disinfection shall be repeated until samples are satisfactory.

SECTION 02611  
BASE AND PAVING

PART 1 - GENERAL

1.01 APPLICABLE STANDARDS

- A. When used in this section, the term "Standard Specifications" shall mean the DEPARTMENT OF TRANSPORTATION, STATE OF GEORGIA STANDARD SPECIFICATIONS FOR CONSTRUCTION OF ROADS AND BRIDGES 2013 or later edition.
- B. American Society for Testing and Materials (ASTM):
  - D-698 Test for, Moisture-Density Relations for soils
  - D-1557 Test for, Moisture-Density Relations for soils

PART 2 - PRODUCTS

2.01 MATERIALS

- A. Base: The base shall conform to Section 310, Graded Aggregate Construction, of the Standard Specifications and must be granite base material.
- B. Prime: The prime coat shall be RC-70 and shall conform with Section 412, Bituminous Prime, of the Standard Specifications.
- C. Tack Coat: The tack coat shall be RC-70 and shall conform with Section 413, Bituminous Tack Coat of the Standard Specifications.
- D. Intermediate Course (Binder): The intermediate course shall be Superpave 19 mm Asphaltic Concrete and shall conform with Section 402, Hot Mix Asphaltic Concrete Construction of the Standard Specifications.
- E. Surface Course - Asphalt Plant Mix: The surface course shall be either Superpave 9.5 mm or 12.5 mm Asphaltic Concrete and shall conform with Section 402, Hot Mix Asphaltic Concrete Construction, of the Standard Specifications.
- F. Paint: Paint for pavement marking shall be in conformance with MUTCD publication and shall conform with Section 870, Paint, of the Standard Specifications.
- G. Concrete Curb and Gutter: Shall conform to Section 441 -Concrete Curb, Gutter, Combination Curb and Gutter, Header, and Median of the Standard Specification.

PART 3 - EXECUTION

3.01 COMPACTION

- A. Sub-grade: The upper 24 inches of sub-grade soils in all cut areas and all fill areas that are to receive new pavements shall be scarified and re-compacted until a density equivalent to 95% standard Proctor maximum dry density in accordance with ASTM D698 has been obtained.



- B. Base: All base shall have minimum compaction of 100% of the maximum density obtained by the test procedure present in ASTM D1557, Method D (Modified Proctor). The maximum permissible lift thickness shall be 6 inches (compacted). The contractor shall be required to perform all work necessary to meet the minimum compaction requirements.
- C. Moisture Content: Compaction shall be performed only when the moisture content of the soil is within 4% of the optimum moisture content at the time of compaction as determined by ASTM D698. Soils are to be dried prior to compaction by discing and aeration. An Independent Testing Laboratory shall determine if soils are within the optimum moisture content. The contractor shall be required to perform all work necessary to meet the minimum compaction requirements.

### 3.02 CONSTRUCTION

- A. Preparation of Sub-grade: Prior to placing of base and pavements, the construction of all utility lines (water, sewer, power, gas, etc.) which are to be placed under the pavements shall have been completed.
- B. Base: The base course shall be constructed in accordance with Section 310 of the Georgia Department of Transportation Standard Specifications to the compacted thickness specified.
- C. Prime: The prime coat shall be applied at a rate of 0.25 gallons per square yard and in accordance with Section 413 of the Georgia Department of Transportation Standard Specifications.
- D. Tack Coat: The tack coat shall be applied at a rate of 0.10 gallons per square yard and in accordance with Section 413 of the Georgia Department of Transportation Standard Specifications.
- E. Intermediate and Surface Course - Asphalt Plant Mix: The intermediate and surface courses shall be constructed in accordance with Section 402 of the Georgia Department of Transportation Standard Specifications to the thickness indicated. All thicknesses are compacted.
- F. Painting Stripe: Pavement striping is required and shall be in accordance with Georgia Department of Transportation MUTCD publication.
- G. Existing pavement which has pavement markings damaged by this construction shall be repainted.
- H. Concrete Curb and Gutter: Shall be constructed in accordance with Section 441 of the Georgia Department of Transportation Standard Specification.

### 3.03 TESTING

- A. Compaction testing shall be performed by an approved testing laboratory. Sub-grade and base compaction testing shall be performed at a spacing not to exceed 500' staggered for the entire length of the street. On streets shorter than 1,000' the testing spacing shall reduce to 300' and in no case will be less than three tests per street, equally spaced. The Design Engineer and the construction Inspector shall be provided copies of the test information prior to placement of base material or final pavement.
- B. Prior to the installation of any curb & gutter or base material a test roll must be performed along the entire roadway length, both sides of the road. The test roll shall be performed utilizing an 18 C.Y. tandem axle dump truck loaded with at least 12 C.Y. of soil or gravel. The same test roll will be required on the base material prior to beginning pavement installation. The Design Engineer and construction Inspector shall be present during the test roll.
- C. Prior to beginning the installation of any asphalt pavement, the base material shall be tested to determine thickness and graded cross section of the base material. The contractor shall provide labor and equipment to auger through the base material to check to insure the thickness specified in the plans and specifications has been achieved. In addition, the cross slope of the base and the depth below the gutter face shall be checked, utilizing a string line, to insure proper crown and asphalt depth at the edge has been achieved with the base grading. If the depth of base material is insufficient the base present will be removed, the subgrade lowered and adequate base material will be replaced to achieve the required thickness. If the cross slope or edge depth is determined to be less than the specified thickness, the area will be rejected until the area is re-graded to the slope and the thickness specified on the approved plan.
- D. The Owner at his option may check the thickness of the asphalt pavement and base material after the installation is complete. If the Owner finds the materials to be less than specified the contractor/developer shall take necessary measures to meet the requirements of the approved plans and specifications.
- E. Prior to any striping being performed, the contractor shall prepare a striping plan for approval by the construction inspector.

### 3.04 EXISTING PAVEMENT RESTORATION

- A. Pavement damaged due to construction shall be patched or replaced in accordance Section 400 of the Georgia Department of Transportation Standards and Specifications.
- B. Pavement damaged by new utility trenches shall be restored in accordance with the pavement removal and replacement details. Any pavement removed must be disposed of by the contractor at a permitted site.
- C. Existing inlets, manholes, or valve boxes shall be adjusted by the Contractor to the new grade lines and elevations. All adjustments to structures in areas proposed for pavement shall be accomplished prior to construction of the surface course.

- D. Adjustment to grade of existing frames shall include raising or lowering the upper portion of the structure, including any necessary sleeve extensions, adjustable manhole rings, gaskets, mortar, masonry or other approved material, to bring the frame to the required grade.

### 3.05 STRIPING OF PAVEMENT MARKINGS

- A. Striping shall consist of furnishing and applying traffic markings with paint or thermoplastic in accordance with the contract drawings and specifications, and the requirements of the current Federal and State "Manual of Uniform Traffic Control Devices."
- B. Thermoplastic Plastic Stripe shall consist of solid or broken (skip) lines, words and/or symbols of the type, color and the location shown on the plans. It is the intent of these specifications that short lines which are defined to be crosswalks, stop bars, arrow symbols and crosshatching shall be extruded. All other lines, unless otherwise specified, shall be sprayed.
- C. Cleaning: All pavement areas to be striped shall be thoroughly cleaned. Cleaning may be accomplished by the use of hand brooms, rotary brooms, air blasts, scrapers or other approved methods which leave the paving surface thoroughly clean and undamaged. Particular care shall be taken to remove all vegetation and road film from the area to be striped.
- D. Warranty: The Contractor shall transfer to the Governing Authority the warranty on Thermoplastic materials issued by the Manufacturer.

Not for Bid

SECTION 02650  
SANITARY SEWERS

PART 1 - GENERAL

1.01 APPLICABLE STANDARDS

A. American National Standards Institute (ANSI):

- A21.4 Cement-Mortar Lining for Cast-Iron and Ductile-Iron Pipe and Fittings for Water
- A21.6 Cast-Iron Pipe Centrifugally Cast in Metal Molds, for Water or Other Liquids
- A21.11 Rubber Gasket Joints for Cast-Iron and Ductile-Iron Pressure Pipe and Fittings
- A21.51 Ductile Iron Pipe, Centrifugally Cast in Metal Molds or Sand-Lined Molds, for Water or Other Liquids

B. American Society of Testing and Materials (ASTM):

- A48 Gray Iron Castings
- C12 Installing Vitrified Clay Sewer Pipe
- C425 Compression Joints for Vitrified Clay Bell and Spigot Pipe
- C478 Precast Reinforced Concrete Manhole Sections
- C594 Compression Couplings for Vitrified Clay Plain-End Pipe
- C700 Extra Strength and Standard Strength Clay and Perforated Clay Pipe
- D1784 Rigid Poly (Vinyl Chloride) Compounds and Chlorinated Poly (Vinyl Chloride) Compounds
- D2241 Poly (Vinyl Chloride) (PVC) Plastic Pipe (SDR-PR and Class T)
- D2321 Underground Installation of Flexible Thermoplastic Sewer Pipe
- D2774 Underground Installation of Thermo-plastic Pressure Piping
- D3034 Type PSM Poly (Vinyl Chloride) (PVC) Sewer Pipe and Fittings
- D3139 Joints for Plastic Pressure Pipes using Flexible Elastomeric Seals
- D3212 Sewer Pipe Joints using Elastomeric Seals

C. American Water Works Association (AWWA):

- C-600 Installation of Cast-Iron Mains

## 1.02 SUBMITTALS

- A. Materials used in the sanitary sewer system shall be submitted for approval to the Design Engineer. The Design Engineer shall review the drawings, provide a list of materials and certify compliance to the Owner.
- B. Six copies of shop drawings or manufacturer's standard drawings or catalog cuts shall be submitted for the following:
  - 1. Precast concrete manholes
  - 2. Manholes and Frames
  - 3. Gaskets - One of each type
  - 4. Pipe - One of each type
  - 5. Valves - One of each type

## 1.03 PRODUCT DELIVERY, STORAGE, AND HANDLING

- A. The Contractor shall be responsible for handling and storage of all materials and damaged materials shall not be used in the work. Materials delivered to the site shall be promptly inspected for damage upon arrival. Damaged or defective materials to be immediately removed from the site.
- B. All materials to be stored at least 12 inches above grade. Inside of pipes and fittings shall be kept free of dirt and debris. Rubber gaskets and plastic pipe not used immediately shall be protected from direct sunlight. Manhole units shall be handled with care to avoid chippage or breakage.

## PART 2 - PRODUCTS

### 2.01 POLYVINYL CHLORIDE PIPE AND FITTINGS

- A. Polyvinyl chloride pipe and fittings for gravity sewers shall be SDR-35 for less than 12' bury and SDR – 26 for 12' bury and over, meeting ASTM D3034 for type PSM Polyvinyl Chloride (PVC) sewer pipe. The joints shall be Push-On "O" ring gasket type with integral bell and spigot meeting ASTM 3212. Threaded or solvent welded type joints shall not be used.
- B. Polyvinyl chloride pressure pipe shall meet one of the following specifications:
  - 1. IPS Size PVC Pipe: Class 200 SDR 21 - Polyvinyl chloride water main pipe shall conform to Designation ASTM D2241 and shall consist of Type I, Grade 1 PVC compound conforming to ASTM D1784. All pipe shall be Class 200, SDR 21. The standard laying length shall be 20 ft. ±1 inch.

2. DIP Size PVC Pipe: AWWA C-900-07

- a. C-900 polyvinyl chloride water main pipe 4" TO 12" shall conform to Designation ASTM D2241 and shall consist of Type I, Grade 1 PVC compound conforming to ASTM D1784. All pipe larger than 4" to 12" shall meet the requirements of AWWA C900, "Poly Vinyl Chloride (PVC) pressure pipe." All pipe shall be class 200 pipe and shall meet the requirements of DR14. The standard laying length shall be 20 ft. ±1 inch. The FM approved pressure class will be used to determine pressure class.
- b. C-905 polyvinyl chloride water main pipe 14" to 30" shall be manufactured from compounds conforming to PVC cell classification of 12454B as defined in ASTM D-1784. The integral bell joint system meets the requirements of ASTM D-3139 and utilizes an elastomeric seal conforming to ASTM F-477. All pipe shall be class 200 pipe and shall meet the requirements of DR18. The standard laying length shall be 20 ft. ±1 inch.
- c. When DIP size PVC pipe is used two 2" PVC pipe shall be SDR 21, 200 PSI pressure class, iron pipe

C. Marking: Pipe shall be clearly marked with:

1. Manufacturer's Identification
2. Nominal Pipe Size
3. Material, Type and Grade
4. SDR or Pressure Rating
5. All gravity sewer pipe shall be green. Force main pipe shall be white or brown.
6. All pipe regardless of color shall be clearly marked **"SEWAGE FORCE MAIN"** or **"GRAVITY SEWER"** as appropriate, marked every three feet.

2.02 DUCTILE IRON PIPE AND FITTING

- A. Type: Coated Ductile
- B. Joints:
  1. Push on type in accordance with ANSI A21.11.
  2. Mechanical joint in accordance with ANSI A21.11 and fittings may be in accordance with A21.53..
- C. Ductile iron pipe shall conform to ANSI A21.51.
- D. Pipe shall have a Protecto 401 lining or equal. The lining should have a high resistance to fatty oils, detergents and sewage generated hydrogen sulfide.

- E. Pipe shall be coated outside with one mil. thick bituminous coating conforming to ANSI A21.4 and AWWA C110, C115OR C151.

#### 2.03 REINFORCED CONCRETE PIPE AND MANHOLES (WET WELLS OR VALVE PITS)

- A. Precast concrete sections to be manufactured in accordance with provisions of ASTM C478. As a minimum, the interior of all sections shall be coated with two coats of bituminous coating. The first coat shall be spray applied and the second coat should be roller applied. In addition, in extremely corrosive environments, to include force main receiving manholes, wetwells, and the first two manhole from the force main connection shall be lined with sealed HDPE sheet liner. The HDPE liner shall have a watertight seal at all joints and penetrations. The liner shall be Agru Sure Grip Liner or equivalent.
- B. Precast concrete riser sections to be 48 inches in diameter with minimum wall thickness of 4 inches.
- C. Precast concrete base units to have minimum wall thickness of 5 inches.
- D. Jointing material shall be rubber gasket type conforming to ASTM C443 or vulcanized butyl rubber base flexible joint sealer in rope form conforming to Federal Specification SS-S-00210, Kent-Seal No. 2 or approved equal. The inside and outside of the joint shall be finished with mortar. Mortar shall be one part Portland cement and two parts sand.
- E. Manhole base sections shall provide for a flexible watertight union between pipe and manhole base. Manhole sleeves shall be of high quality synthetic rubber with tensile strength of 1,500 psi, resistant to raw sewage, ozone, acids, and weathering, flexible at temperatures below 0°F and resistant to heat as high as 250°F. A substantial, serrated flange of the sleeve material shall be integrally cast into the wall of the manhole base forming a tight water seal. The sleeve shall protrude through the wall of the base. A watertight union shall be secured with the end of the pipe with stainless steel strap clamps. Manhole sleeves shall be Interpace Corp. Lock Joint Manhole Sleeves or approved equal.
- F. Pick up holes shall not penetrate the interior walls or the riser.

#### 2.04 MANHOLE FRAMES AND COVERS

- A. Frames and covers to have machined bearing surfaces.
- B. Covers to have checkered top design and marked "Sanitary Sewer" and include the name of the utility owner.
- C. Combined weight of frame and cover shall be approximately 450 pounds.
- D. Frame shall have a depth of approximately 9 inches and an access opening of not less than 20 inches.
- E. Covers shall have two pick holes located at edges.
- F. Materials shall conform to ASTM A48 for Class 30 gray iron castings.

## 2.05 MANHOLE STEPS

- A. Manhole steps shall be constructed of a number 3 reinforcing bar encapsulated in polypropylene plastic with a non-skid tread.
- B. Finished dimensions of the steps shall be identical to that of malleable iron manhole steps.
- C. Steps to have a minimum tread width of 12 inches.

## 2.06 NUTS AND BOLTS

- A. Stainless Steel Flanged: Square head MB/SF, hexagon nuts; ASTM 307B; ANSI B18.2, zinc plated.

## 2.07 GASKETS

- A. Flanged pipe gaskets shall conform to requirements of ASA A21.10 and shall be suitable for the indicated services.

## 2.08 VALVES

- A. All valves two inches in diameter and smaller shall be constructed of brass or bronze except the hand wheel, which shall be of malleable iron construction. Valves two inches in diameter and smaller shall have screwed ends unless approved otherwise. All valves 2½ inches in diameter and larger shall have flanged ends unless otherwise approved. They shall be iron body, bronze mounted, except that in the smaller sizes the valves may be all bronze at the contractors option and expense.
- B. The contractor shall prepare and submit for approval complete detailed drawings of all valves in accordance with the requirements of the appropriate section of these specifications. All valves of the same type shall be from a single manufacturer. Parts of valves of the same type and size shall be interchangeable. Spare parts shall be furnished as specified under the proposal items. Special tools required for repacking or disassembling valves shall be provided.
- C. All valves shall be carefully mounted in their respective positions free from all distortion and strain. All valves shall be properly packed and left in satisfactory operating condition at the completion of the project. All valves shall open left.
- D. Gate Valves
  - 1. Gate valves should not be used in raw sewage applications. Gate valves should only be used where primary and partial secondary treatment has already occurred.
  - 2. Unless otherwise specified or directed, gate valves three inches and larger shall have non- rising stems and shall meet the requirements of AWWA Standard C-500. Valves for lighter pressures than the AWWA Standard shall meet the requirements of the above specifications except that the requirements for metal thicknesses and strengths and structural designs shall be adjusted as required to meet hydrostatic test pressures not less than 125 psi.



3. Unless otherwise specified or directed, gate valves smaller than three inches shall meet the requirements of Federal Specification WW-V-54, Class A, 125 pounds.
4. All gate valves shall have standard stuffing box seals. Bonnet bolts, studs and nuts shall be cadmium plated. Seating devices shall be bronze to iron or bronze to bronze as specified or required. The glands shall be bronze or bronze bushed. Gland bolts and nuts shall be bronze.
5. All gate valves 2½ inches in diameter and larger shall be of the double disk type. All gate valves two inches in diameter and smaller may be of the double disk or the solid wedge type.

E. Plug Valves

1. All plug valves shall be the two-way type.
2. Nonlubricated, eccentric with resilient faced plugs.
3. Port area of 4 to 20 inch valves shall be at least 70 percent of full pipe area.
4. Valves to be designed for 125 psi working pressure.
5. Bodies to be semisteel with raised seats.
6. Seats to have either a welded-in overlay of approximately 90 percent pure nickel on surfaces contacting the plug face or shall be bronze conforming to ASTM B-62 and attached to the body by stainless steel set screws.
7. Upper and lower plug stem bushings to be stainless steel and shall be permanently lubricated.
8. Exposed nuts, bolts and washers to be zinc plated.
9. Flanges to be faced and drilled to ASA 125 pound standard.

F. Check Valves

1. Type: Ball Check
  - a. Static head must exceed 10 feet to use ball check valves.
  - b. No ball check valve will be mounted vertically to compensate for low static head.
  - c. Ball check ends must be flanged.
  - d. The body shall be cast iron, ASTM A159-72, Class 35.
  - e. The ball shall be hollow steel with vulcanized nitrile rubber covering.
  - f. Pressure rating shall be 150 psi.
  - g. Valve to be Flygt HDL or equal.

2. Lever Actuate Spring Check Valve

- a. Where static head is less than 10 feet lever action swing check valves shall be used.
- b. Lever action swing checks may be spring and lever type or weight on lever type as approved by the design engineer and the Owner.
- c. Valves shall be installed in the horizontal position.
- d. The valve body, disc, cover and lever shall be cast iron, ASTM A159-72, Class 35.
- e. The disc arm shall be cast steel
- f. The seat ring shall be bronze or stainless steel.
- g. All studs, bolts or nuts shall be commercial grade steel.
- h. The gate shall be rubber faced.
- i. The hinge shaft shall be stainless steel.
- j. The chamber shall be bronze.
- k. The valve shall be Clow F5340 (outside spring and lever) or Clow F5345 (outside weight and lever) or an approved equal.

G. Automatic Sewage Air Release Valve

1. The automatic sewage air release valve shall be designed to allow entrapped air to escape from the sewage force main line. After the air escapes out of the air release valve, the valve shall shut-off until more air accumulates in it and the opening cycle will repeat automatically.
2. The sewage release valve must have a compound internal linkage of precision molded delfin or stainless steel. All other internals must be stainless steel to positively prevent galvanic action. The float rod shall be 20" long to provide an air gap between the linkage and waste level inside the valve to retard the waste solids from clogging the linkage. The stainless steel float must withstand a minimum 1000 psi pressure. Each valve shall be complete with hose and blow off valves to permit back flushing without dismantling valve.

Body and cover cast iron	ASTM A48 Class 30
Internal Delfin linkage	ASTMD2133 (or Stainless Steel)
Stainless Float	ASTM A240
Buna-N	ASTM SB800

3. Typical installation will utilize standard body valve. Valve height 28"-with back flushing attachments-33-1/2". If depth of trench is not deep enough, furnish short valve. Valve height 17-1/2" -with back flushing attachments-23-1/2".

4. Automatic sewage air release valve to be as manufactured by Crispin, Val-matic, or APCO equal to APCO Series 400 with accessories.

## 2.09 ACCESSORIES, PLUG, AND GATE VALVES

- A. Valves to have two inch square operating nut unless otherwise indicated.
- B. Valves buried in ground or located in vaults or structures to have suitable extensions for socket operation with top of operating nut located two feet below finished grades maximum.

## PART 3 - EXECUTION

### 3.01 INSTALLATION

- A. Plastic piping installation shall be in accordance with ASTM D2321 Recommended Practice for non-pressure pipe and ASTM D2774 Recommended Practice for pressure pipe.
- B. Ductile iron pressure piping shall be installed in accordance with AWWA Standard C600.
- C. Material selection for piping material shall be as indicated. If piping materials are not indicated the Contractor has the option of selecting materials in accordance with this section.
- D. Service sewer lines shall be constructed of same material as the mains.
- E. Sewer lines shall not be laid closer than 10 feet horizontally to a water main. Pressure sewer lines shall pass beneath water lines, with the top of the sewer being at least 18 inches below the bottom of the water line. Where sanitary sewer lines pass beneath water lines, no joints in the sewer line shall be closer than 10 feet, horizontal the water line. When the vertical or horizontal separation cannot be accomplished, then concrete encasement shall extend a minimum of 10 feet on both sides of crossing.
- F. Pipe laying to proceed up-grade with pipe bells or groove on the upper end. Pipe to be laid with joints close and even, butting all around. Sagging joints will not be tolerated.
- G. Pipe shall be straight and of uniform grade between manholes, laid to line and grade.
- H. All sewer shall be designed and constructed to give velocities of not less than 2.0 FPS. Since the Owner has adopted a low flow plumbing device ordinance, the following slopes will be used.

Minimum Slope in Feet  
Sewer Size            Per 100 Feet

8"	0.44
10"	0.30
12"	0.24
15"	0.15
18"	0.12
21"	0.10
24"	0.08
30"	0.058
36"	0.046

- I. An allowable deviation from the design grades will be allowed up to 5% of the grade shown on the plan. If the grade is steeper than allowed 5% deviation the engineer must verify that the project was installed to all minimum requirements and determine the impact of the additional grade. If the grade is flatter than the 5% deviation, then it exceeds the allowable tolerance and the installation of that line is not acceptable and must be replaced. All sewer mains installed will be field checked for grades during preparation of "Record drawings".
- I. Bell holes shall be dug so the pipe barrel will carry the load of the pipe. Pipe shall be bedded in undisturbed earth or, where rock occurs, on a thoroughly compacted layer of #57 stone or sand fill of a minimum thickness of 6 inches under the barrel or bell of the pipe.
- J. Where sewers or force mains are to be connected to existing manholes or other structures, and where no stub or opening has been provided for the connection, the Contractor shall make an opening of minimum diameter through the side wall of the structure utilizing a professional coring machine and installing a boot for inserting the sewer pipe. The boot and stainless steel strap shall be sized and installed to create a water tight seal.
- K. Lateral connection made to the sewer prior to back-filling shall be laid on a slope not exceeding 2 feet vertical to 1 foot horizontal, and not less than 1/8 inch per foot, so that the lateral shall have a solid bearing on undisturbed earth as stipulated for pipe sewers. The lateral shall make such a horizontal angle with the sewer line that a proper connection with the wye or tee branch or slant is obtained without trimming the pipe and with no danger of jointing material being forced into the sewer. All laterals shall be closed by means of suitable stoppers or end caps.
- L. Wye or tee branches shall be field located for service to all subdivided lots or inhabitable structures unless otherwise directed by the Architect/Engineer. Wye branches shall be installed so that the lower lip of the branch is not more than 2 inches below the outside top of the pipe. Tees shall be installed with the branch 45° to vertical. After installation, wye or tee branches shall not be covered with backfill until determination and record has been made of the locations of each with reference to the nearest manhole downstream and the direction in which the wye faces.

- M. All laterals shall be properly marked on ground surface at the point where laterals terminate with treated timber markers. Timber markers shall consist of a 2 inch by 4 inch timber extending from the end of the lateral vertically to within 2 inches of the ground surface. All such markers shall be securely anchored and maintained in a proper vertical position until backfilling has been completed. The top end of such markers shall be marked or left exposed until an "as-built" survey has been made.
- N. The top rim of manhole frames and covers shall be set to conform to grades and transverse slopes. Generally along outfall lines, the manhole frames and covers shall extend approximately 6 inches above finished grade or to a designated elevation for flood protection. Generally where lines are located along streets, the manhole frames and covers shall be set flush with the surface.
- O. The Contractor shall install a continuous run of plasticized metallic tape above the top of the sewer main at 12 inches to 18 inches below finished grade. Tape shall be suitable for detection with metal pipe location equipment labeled "sewer buried below," and brightly colored to contrast with the soil.
- P. A 14 gauge copper tracer wire with underground coating shall be installed along the route of pressure sewers. The wire shall be located 12 inches above the pipe but no deeper than 48 inches.
- Q. All PVC pressure pipe shall have a minimum of 36" cover. Areas where the cover is not maintained may require the use of extra strength (D.I.) pipe as directed by the engineer.
- R. All sewer mains will be installed at a constant grade and line as shown on the plans. If after video inspection "sags" are found in the line, then the depth of the sag will be determined by the utility owner. If the sag is determined to be deeper than the following chart then the line will be removed and replaced to meet the minimum requirements of these specifications.

Pipe Size	Max. Sag Depth
8"	0.50"
10"	0.50"
12"	0.75"
15"	0.75"
18"	0.75"

### 3.02 PRESSURE TESTS

- A. **FORCE MAINS:** The Contractor shall test by hydrostatic pressure to 150 pounds per square inch. Each section tested shall be slowly filled with water, care being taken to expel all air from the pipes. The required pressure shall be applied for not less than two hours. No pipe installation will be accepted until the leakage during the pressure test is less than the number of gallons listed below for each 1000 feet of pipe.

6" - 1.5 gallons	12" - 2.75 gallons
8" - 1.75 gallons	14" - 3.00 gallons
10" - 2.75 gallons	16" - 3.5 gallons

- B. GRAVITY MAINS: On All sewer mains less than 8' deep, the Contractor shall pressure test the gravity mains with air. Each section including manholes shall be pressurized to 3.5 psi. The allowable pressure drop of 0.5 psi on any portion of the system shall not be less than the times shown on the following chart.

<u>PIPE SIZE</u>	<u>MINIMUM TIME</u>
4"	3 MIN.
6"	4 MIN.
8"	6 MIN.
10"	7 MIN.
12"	8 MIN.

If the main will not maintain the specified pressure, the Contractor will isolate the weak joint and repair. The test will be repeated until successful. The service lines must be installed at least to the back of the curb prior to testing. These pressure drops represent a maximum infiltration/exfiltration rate of 25 gallons per inch of pipe diameter per mile per 24 hour period.

### 3.03 ALLOWABLE INFILTRATION/EXFILTRATION

- A. If any visible flow is observed in the pipe during installation or final inspection a weir test will be conducted.
- B. The leakage inward or outward (infiltration or exfiltration) of the entire system including the sewer mains, service sewers, manholes and wet wells shall not exceed 25 gallons per inch of pipe diameter per mile per day for any section of the system.
- C. The weir shall be installed in each manhole. The manhole will then be filled with water to a depth of 3' from the top of the pipe, which should be at the bottom of the weir. The water level will stand for one (1) hour to stabilize then filled (if necessary) to the initial level. During the next hour the water level will be observed and the amount flowing through the weir or the amount of water required to maintain the level will be measured. This measured amount should not exceed the allowable.

### 3.04 INSPECTION

- A. Upon complete installation of the gravity sewer, the Contractor must enter a waiting period of not less than 10 days prior to inspection. In order to initiate the waiting period, the Contractor must notify the Design Engineer and the LCPC inspector in writing of the status of the sewer.
- B. After completion of the waiting period all sewer mains must pass a 5% deflection mandrel pulled by hand. If a 5% deflection mandrel will not pass through any section, that section will be replaced or rerounded at the expense of the Contractor. Mandrel to be supplied by the City of Hinesville inspector.
- C. Once the mandrel and physical inspection is complete the contractor will schedule a time when the owner may internally inspect the sewer main utilizing a sewer camera and generating a video inspection of the system. If any defects are found in the system as a result of the internal inspection then, that section of the sewer main and any mains feeding into that system will not be accepted.

- C. No sewer main will be accepted if there is any evidence of sagging or bowing in the line which will adversely effect the performance of the pipe. Nor will any sewer mains be accepted if they are laid on a grade substantially less that specified on the Construction Plans. No line will be accepted if laid on less grade than the minimum stated in this specification.
- D. All manholes will be inspected for general appearance, cracks, leaks, proper installation of frame and cover, steps and inverts. Any manholes, which do not conform to the specifications, will not be accepted until the deficiency is corrected by the Contractor.
- E. All 4" sewer services will be tested for continuity and minimum bends by passing a standard tennis ball. Each sewer service shall be temporarily capped during construction. During the inspection, a tennis ball will be dropped down the open end of the sewer service. If the ball does not appear in the lower manhole the contractor will excavate the service, correct the blockage and repeat the test until successful.
- F. All manhole and wetwell liner systems shall be tested using the "Spark Test" to locate incomplete welds or penetrations in the liner not adequately sealed for gas containment.

### 3.05 CLEANING

- A. Contractor to clean the completed system of any debris or obstructions prior to Final Inspection.

Not for Bid

SECTION 02821  
GRASSING

PART 1 - GENERAL

1.01 APPLICABLE STANDARDS

- A. Conform to Section 700 and other applicable articles of the "Standard Specifications Construction of Transportation Systems", of the Department of Transportation, State of Georgia, dated April 18, 2013. Omit all references to measurement and payment.

1.02 SOIL SAMPLES

- A. The Contractor shall take soil samples from several areas of the site to be grassed and have them analyzed by the Georgia Extension Service. The results of the analysis shall determine the best fertilizer mixture to use on the site.

PART 2 - MATERIALS

2.01 FERTILIZER

- A. Commercial Fertilizer: Fertilizer for lawns shall be a complete fertilizer, the nitrogen content of which shall be derived from either organic or inorganic sources and meeting the following minimum requirements of plant food by weight, unless the soil analysis and report indicates a need for a different fertilizer mixture in which case the recommended mixture shall be furnished and applied. All State and Federal laws relative to fertilizer must be complied with.

10% Nitrogen - 12% Phosphoric Acid - 12% Potash

- B. Ground Limestone: Lime shall be ground dolomitic limestone containing not less than 85% of total carbonates and shall be ground to such fineness that 50% will pass through a 20-mesh sieve. Coarser material will be acceptable, provided the specified rates of application are increased proportionately on the basis of quantities passing the 100-mesh sieve.
- C. Sodium Nitrate shall be a commercial product in dry powder form and shall be delivered in the original, unopened containers each bearing the manufacturer's guaranteed statement of analysis. It shall contain not less than 16% Nitrogen.

2.02 LAWN MATERIALS

- A. Kentucky 31 Fescue (Fescue elatior: var. arundinacea): Seed shall be 98% minimum purity and 85% germination.
- B. Bermuda Grass (Cyanodon Dactylon): Seed shall be 98% minimum purity and 85% germination.



## PART 3 - EXECUTION

### 3.01 PREPARATION

- A. Prepare the seed bed by thoroughly cultivating, discing and hand raking as necessary to produce a smooth even grade free from hollows or other inequalities. Before any seeding is attempted the soil must be in a well pulverized, smooth, friable condition of uniformly fine texture.

### 3.02 FERTILIZING AND LIMING

- A. Approximately two (2) days prior to the start of seeding operations, apply ground limestone at the rate of 20 pounds per 1000 sq. ft. of lawn area. Either in conjunction with the above operation or immediately afterwards apply the specified Commercial Fertilizer over all lawn areas at the rate of 30 pounds per 1000 sq. ft. of lawn area. Work limestone into the top 6 inches of ground and the fertilizer into the top 2 inches of ground.
- B. When the grass has started to cover well (approximately 4 weeks after sowing seed) apply 1-1/2 pounds of Ammonium Nitrate to all lawn areas and immediately water using a fine spray. At the end of the maintenance period and prior to the final inspection apply 10 pounds of the specified Commercial Fertilizer per 1000 sq. ft. of lawn area and immediately water.

### 3.03 SEEDING

- A. Before any seeding is attempted the soil must be in a well pulverized, smooth, friable condition of uniformly fine texture. Lawn areas shall be seeded evenly with a mechanical spreader at the rate of 2 lbs. of seed per 1000 sq. ft., 50% in one direction and the remainder sown at right angles to first sowing. The seeded areas shall be lightly raked, rolled with a suitable weight roller and watered with a fine spray.
- B. Fescue planting season shall be as approved by Engineer.
- C. Bermuda Grass seeding shall be planted only between May 1 to September 1.
- D. When grassing is required between curbs and sidewalks, behind sidewalks in areas adjacent to private property, the Engineer may change the type of seeding to that required to match any type of grass which may be planted and growing on the adjacent lawn. No increase in the Contract Sum will be made for this substitution.

### 3.04 WATERING

- A. Soak soil to a minimum depth of 6 inches immediately after seeding. Do not wash away soil or seed. Keep all surfaces continuously moist thereafter until 30 days after the lawn has been seeded. Use fine spray nozzles only.

### 3.05 RESPONSIBILITY

- A. Maintenance of grass areas shall consist of watering, weeding, cutting, repair of any erosion and reseeded or resodding as necessary to establish a uniform stand of the specified grasses, and shall continue until final acceptance.
- B. All grassed areas that do not show satisfactory growth within 15 days after sowing shall be re-sown and re-fertilized as directed until a satisfactory blanket is established. Approximately 3 weeks after sowing the last seed, but not before the seed has taken hold and the grass is growing well, apply sulfate of ammonia or sodium nitrate at the rate of 300 pounds to the acre and water immediately. The lawns shall be considered established when they are reasonably free from weed, green in appearance and the specified grass is vigorous and growing well on each square foot of lawn area. Full coverage is required in 60 days.
- C. All grassed areas shall be protected until accepted. All eroded and damaged areas, regardless of cause, shall be immediately repaired and reseeded. Protect lawn areas against traffic.
- D. Grassed areas shall be covered evenly with a loose layer of clean wheat, rye, oats, Serecia Lespedeza or Coastal Bermuda Hay. Two tons of dry mulch shall be applied to each acre seeded. Hay shall be placed during calm weather with no wind.
- E. As soon as the grass becomes established, a final inspection of the work will be made, provided a written request for such inspection is given to the Engineer. Satisfactory coverage is defined as coverage of the areas seeded with grass that is alive and growing, leaving no bare spots larger than one (1) square foot with 98% coverage.
- F. All temporary valves, cutoffs and piping shall be removed by the Contractor at final acceptance of the grassing.

SECTION 03300  
CONCRETE GENERAL

PART 1 - GENERAL

1.01 QUALITY STANDARDS

A. Any procedure and material operation specified by reference to the following publications shall comply with the requirements of the current specification or standard:

1. American Society for Testing Materials (ASTM):

- A185 Welded Steel Wire Fabric for Concrete Reinforcement.
- A615 Deformed Billet-Steel Bars for Concrete Reinforcement.
- C31 Method of Making and Curing Concrete Compression and Flexure Test Specimens in the Field.
- C33 Specification for Concrete Aggregate.
- C39 Compressive Strength of Molded Concrete Cylinders.
- C94 Specification for Ready-Mixed Concrete.
- C143 Slump of Portland Cement Concrete.
- C150 Portland Cement.
- C172 Sampling Fresh Concrete.
- C192 Making and Curing Concrete Test Specimens in the Laboratory.
- D1751 Preformed Expansion Joint Fillers for Concrete Paving.

2. American Concrete Institute:

- ACI 301 Specification for Structural Concrete for Buildings.
- ACI 305 Recommended Practice for Hot Weather Concreting.
- ACI 318 Building Code Requirements for Reinforced Concrete.

1.02 QUALITY CONTROL

- A. The Contractor shall submit to the Engineer, for review a design mix for each class of concrete listed under CLASSES OF CONCRETE, prior to placing any concrete.
- B. Verification tests of design mixes and aggregates are required by the Engineer. Verification test specimens shall be made in accordance with ASTM C39 by an Independent Test Laboratory. Compressive strength shown by verification tests shall be at least fifteen percent in excess of the strengths listed under CLASSES OF CON-

CRETE. The Independent Testing Laboratory shall report the test results to the Engineer, in writing and shall note any failure to meet the specification.

- C. Verification tests of design mixes made not more than one year prior to the date of submittal will be acceptable provided they were made from materials identical to those to be used in the project.
- D. Mill Test: Conducted in accordance with ASTM A615 recommendations on each 15 tons, or less reinforcing shipped to the job. Two (2) copies of test to be sent to the Engineer.
- E. Inspection and Testing of Concrete:
  - 1. The cost of slump tests and sampling, molding, storing, materials, transporting concrete test specimens shall be paid by the Contractor. The laboratory or inspection agency shall be selected by the Owner. Costs of all laboratory testing services required because of failure to meet the requirements of these specifications shall be paid by the Contractor.
  - 2. One set of four (4) acceptance cylinders shall be prepared for each day's placing of each strength of concrete and if more than 50 cubic yards of concrete is placed in any day, there shall be an additional set of cylinders prepared for each 50 cubic yards placed or for any fraction thereof. One cylinder shall be broken at seven days and two at twenty-eight days, with one cylinder held in reserve.
  - 3. Responsibilities in Inspection:
    - a. Laboratory's Duties
      - 1. The reception and marking of specimens in the laboratory, laboratory curing, preparation for breaking and testing of cylinders shall be the responsibility of the laboratory and shall be performed by qualified laboratory personnel, observing all requirements of applicable ASTM Standards. Compression test specimens shall be tested in accordance with ASTM C39.
      - 2. Prior to the commencement of concrete work, the laboratory shall provide initial instruction in the performance of sampling and testing duties for an employee designated by the Contractor and shall provide him with copies of all ASTM Standards pertinent to his duties.
    - b. Contractor's Duties:
      - 1. The Contractor shall deliver to the laboratory all materials to be used in required testing. He shall supply wheelbarrows, shovels, mixing boards, shaded work space and similar equipment required for molding test cylinders. He shall provide stable, insulated storage boxes, equipped with thermostatically controlled heat, for storage of cylinders in the first 24 hours after molding.

2. He shall designate an employee, who alone shall perform all operations of sampling concrete, molding test specimens, protecting test specimens for the first 24 hours after molding, and packing and shipping of test specimens. The employee shall make a record of a slump test in connection with each truckload of concrete. The designated employee shall receive initial instruction in the performance of his sampling and testing duties from a representative of the testing laboratory and shall have available copies of all ASTM Standards pertinent to his duties. Sampling shall conform to ASTM C172. Slump tests shall conform to ASTM C143. Compression test specimens shall be made and cured in accordance with ASTM C31.
3. Each set of test cylinders shipped to the laboratory shall be accompanied by a report giving information as to location in the structure of concrete sampled, time and date of sampling, air temperature, slump, class designated nominal strength, air content if applicable, temperature of concrete, truck number, and time batched. Each report shall be signed by the employee making the test and by the Contractor or his representative, certifying that the test specimens have been made by the one designated, fully instructed employee and have been made in accordance with applicable standard specifications.
4. Should any concrete fail to meet the specified strength, have a slump in excess of that required by the design mix for each class of concrete listed under CLASSES OF CONCRETE, or result in voids, honeycombs or otherwise fail to meet the requirements, the Engineer may order the concrete removed, further tests made, or other remedial measures taken, all at the Contractor's expense.

#### 1.03 SHOP DRAWINGS

- A. After making his check the Contractor shall submit to the Engineer one (1) blue line copy of each of placing plans, bending details and bar lists covering all reinforcing steel.
- B. Full information for checking and for proper installation without reference to other drawings shall be included. At splices the amount of lap shall be shown. Location and arrangement of accessories shall be clearly shown. Elevations shall be drawn for all reinforced masonry and reinforced concrete walls to a scale no smaller than 1/4 inch = 1 foot.
- C. Work shall not proceed before the Contractor has received shop drawings approved by the Engineer. The Contractor shall be responsible for the conformation of all typical and special reinforcing steel details.
- D. Engineer's review is for conformance to the design concept and contract documents. Markings or comments shall not be construed as relieving the Contractor from compliance with the project plans and specifications, nor departures therefrom. The Contractor remains responsible for details and accuracy, for selecting fabrication processes, for techniques of assembly, and for performing his work in a safe manner.

- E. Proposed construction joint shall be clearly indicated on shop drawings and subject to approval of the Engineer.

#### 1.04 INSPECTION

- A. The Contractor shall give the Engineer 24 hours advance notice before starting to place concrete in any portion of the structure to permit observation. An authorization of the Engineer shall be secured before concrete is placed. Any concrete placed in violation to this provision shall be replaced by new concrete if required by the Engineer.
- B. Prior to notification of the Engineer, the Superintendent shall personally inspect the work and verify that it is ready for observation.
- C. At the time of observation, all reinforcing in the area where concrete is to be poured shall be in place, tied and ready for the placement of concrete. All anchors, sleeves, inserts, etc., shall be securely held in position.

#### 1.05 STORAGE

- A. Reinforcing steel delivered to the job and not immediately placed in forms shall be placed in racks or other supports at least eighteen (18) inches above ground.

### PART 2 - MATERIALS

#### 2.01 CEMENT

- A. Portland cement shall conform to ASTM C150, Type I.

#### 2.02 AGGREGATES

- A. Aggregates for standard weight concrete shall conform to ASTM C33, maximum size: 3/4 inch.

#### 2.03 WATER

- A. Mixing water shall be potable.

#### 2.04 REINFORCING STEEL

- A. Reinforcing bars shall be American manufactured conforming to the requirements of ASTM A615 "Deformed Billet Steel Bars for Concrete Reinforcement", Grade 60.
- B. Welded wire-fabric or cold-drawn wire for concrete reinforcement shall be of American manufacture and shall conform to the requirements of the ASTM A185 "Welded Steel Fabric for Concrete Reinforcement".
- C. Accessories shall conform to the requirements of C.R.S.I. Manual.

## 2.05 READY MIXED STRUCTURAL CONCRETE:

- A. Ready mix concrete shall be mixed and delivered in accordance with these specifications and requirements set forth in ASTM C94. In addition, these following conditions must be met:
1. Concrete shall be normal weight with an ultimate compressive strength at 28 days, and slump as follows:
  2. Air entrained concrete shall be used for all structural concrete with the air content not less than 3 percent and no more than 5 percent.
- B. Classes of Concrete:
- Class A  $f_c = 3000$  psi, Slump 4 inches +/- 1 inch  
Class AA  $f_c = 4000$  psi, Slump 3 inches +/- 1 inch  
Class B  $f_c = 5000$  psi, Slump 5 inches +/- 1 inch

## 2.06 EXPANSION JOINT MATERIAL

- A. Expansion joint material at slabs on grade shall be premolded asphalt saturated cellulose fiber or mineral strips conforming to ASTM D1751.

## 2.07 WALL TIES

- A. Ties shall be made with break back ends or other means of removing the tie end to a depth of at least 1 inch from the concrete surface after the forms are removed.

## 2.08 LIQUID FORM SEALER

- A. Form sealer shall be a standard product compatible with the finish required for exposed concrete and shall contain no paraffin oil or mineral oil.

## PART 3 – EXECUTION

### 3.01 FORMWORK

- A. Forms shall conform to the shapes, lines and dimensions of the members as indicated, and shall be substantial and sufficiently tight to prevent leakage of mortar. They shall be braced or tied together so as to maintain position and shape.
- B. Formwork shall be observed by the Engineer before pouring concrete. Before placing the reinforcement, surfaces of wood forms in contact with the concrete, unless lined, shall receive a thorough coating of form sealer. The Engineer shall have the right to reject any forms that do not appear to him to be sufficient as to alignment and of producing the required finished surface. Should misalignment of forms or screed, excessive deflection of forms or displacement of reinforcing occur during concrete placing, corrective measures shall be immediately made to the extent, if necessary, that placing operations shall be stopped and concrete removed from within forms. The surfaces to required dimensions and cross section. Exposed lines and surfaces shall not vary from dimensions shown on plans by more than 1/4 inch in twenty feet.

- C. Forms may be constructed of wood or metal. Earth forms for footings may be permitted if local conditions are favorable, and approved by the Engineer. Form work for exposed concrete shall be form grade plywood.
- D. Studs, waler, and ties shall be so spaced that the load of wet concrete will not stress ties beyond the printed working load recommended by the manufacturer not cause spans of form material to deflect from a true surface.
- E. The Contractor shall maintain a continuous check upon formwork during the placing of concrete. An instrument check shall be periodically made or "Tattle Tail" rods or other devices shall be used to detect any settlement in forms.
- F. Conduits in Concrete: Conduits shall not displace reinforcing steel from its intended position, nor impair the strength of the structure.
- G. The Contractor shall assume all responsibility for removal of formwork. Elevated concrete slabs shall attain 70% of the specified ultimate strength before removing the forms. After removing forms, slabs shall be reshored at mid-span and at all points under shores supporting forms for the work above. No floor shall be loaded in excess of the live load for which designed unless adequate shores are place beneath members supporting the concrete of load.

### 3.02 PLACING REINFORCING STEEL

- A. Reinforcement shall be shop fabricated, accurately positioned and secured with not less than 16 gauge annealed wire or suitable clips.
- B. No bars, partially embedded in concrete shall be field bent, unless noted otherwise.
- C. Reinforcing bars shall be accurately placed and secured in position by approved chairs, spacers or ties to maintain the position of the reinforcing steel prior to and during placing of concrete.
- D. Reinforcing steel support chairs and bolsters for use in concrete to be exposed shall have galvanized steel leg.
- E. No splices shall be made, except as shown on approved Shop Drawings or approved in writing by the Engineer.
- F. The placement of reinforcement shall be observed by the Engineer before pouring of concrete. Should there be any delay in the work, reinforcement previously placed shall be reinspected and cleaned if necessary before concrete placement is resumed.
- G. Metal reinforcement shall be protected by concrete cover. Where not otherwise shown, the thickness of concrete over the reinforcement shall be as follows:

Footings	3" clear sides and bottom
Slabs	3/4" clear, top and bottom
Beams	2" clear, all around
Walls	2" clear, both faces
Columns & Piers	2" clear



- H. All splicing or reinforcement not shown shall be approved by the Engineer. Splices shall not be made at a point of maximum stress and shall provide sufficient lap to transfer the stress between bars by bond. Hook and bending details, column tie arrangements, etc., shall be as shown by the S.R.A.I. Manual or the ACI Detail Engineering Manual.
- I. Wire mesh reinforcing shall be placed one inch from top of concrete slabs on ground. Lap all joints 12 inches and extend mesh to within 1 inch of sides and ends of slabs.

### 3.03 CONCRETE MIXING AND PLACING

- A. Ready-mix concrete shall conform to ASTM C94. Not more than one hour shall elapse between the time mixing water is added to the batch and the concrete is poured. No water shall be added on the job.
- B. No concrete shall be placed until all embedded items and reinforcing have been placed in the forms and observed by the Engineer. At least 24 hour notice shall be given the Engineer of an impending pour, so that he may observe the work, prior to placing.
- C. Concrete shall be conveyed from the mixer to the place of final deposit by methods that will prevent segregation or loss of materials.
- D. Concrete shall be deposited in its final position to avoid segregations and separation do to rehandling or flowing. The placing shall be carried on at such a rate that concrete is at all times plastic and flows readily into the spaces between bars. When placing is once started, it shall be carried on as a continuous operation, until placement of that section is completed.
- E. Concrete shall be worked into and around bars and embedded items with spades, rods, trowels and vibrators, so as to produce a solid homogeneous mass, free of voids, pockets or honeycombs.
- F. Construction joints shall be installed and located as indicated. Where a joint occurs, the surface of the concrete shall be thoroughly cleaned and all laitance removed and shall be left rough or mechanically roughened, thoroughly wetted and slushed with a coat of neat cement grout immediately before placement of new concrete.
- G. All embedded items, including anchor bolts and dowels, shall be in place, preset and held in position, before any concrete is placed.
- H. No concreting shall be performed when ambient temperatures are below 40°F or if the temperature is predicted by the local U.S. Weather Bureau will fall below 40°F within 24 hours after the time of installation.
- I. No concrete shall be installed against frozen ground. All foundation cavities and slab areas that have frozen, shall be thoroughly clean of all loose earth prior to pouring concrete.
- J. All newly poured concrete shall be protected from freezing or near freezing weather during the cure period.

- K. Hot weather precautions shall be taken whenever the maximum air temperature exceeds 80°F during the day. Hot weather concreting shall be performed in accordance with ACI 305.

#### 3.04 EXPANSION/CONTROL JOINT INSTALLATION

- A. Expansion joints shall be placed a maximum of 20 ft. intervals and at all intersections with steps, curbs other walks or abutting structures. Joints shall extend from the surface to the subgrade at right angles to the sidewalk.
- B. Expansion joint filler shall be 1/2 inch thick and as wide as the full width and depth of the sidewalk.
- C. Control joints (tooled or saw-cut) shall be placed at no less than 12 and no more than 15 ft. intervals, in a square grid, throughout the full length and width of the concrete slab. All control joints shall be filled with semi-rigid epoxy, specifically manufactured for the sealing of control joints in concrete slab construction, to create a water tight slab.

#### 3.05 ANCHORAGE

- A. Slots, inserts, and connections elements for anchoring items to concrete shall be built into forms before placing concrete.

#### 3.06 SLABS ON GRADE

- A. Concrete shall be compacted, screeded to grade and prepared for the specified finish. Slabs shall be placed in panels in alternate checkerboard pattern or in alternate lanes divided into panels. Each panel shall be approximately square terminated by slab joints.
- B. Contraction joints shall be true to line 1/8 inch wide, and of depth equal to approximately 1/4 of the slab thickness. Joints shall be sawed or formed.

#### 3.07 CURING

- A. Provisions shall be made for maintaining concrete in a moist condition for at least 10 days after the placement of the concrete, or by one of the following methods:
  1. Spraying with water or ponding.
  2. Using moisture retaining covers.
  3. Concrete curing compound, W.R. Meadows CS-309 or Guardian Chemical Co., Master Builders or Triple-Cure by Cobra Chemicals.
- B. The spraying water shall be applied on unformed surfaces within one hour after the forms are stripped and the spraying shall be continuous. The moisture retaining cover shall be applied on unformed surfaces immediately after the concrete is finished. If there is any delay, the concrete shall be kept moist until the application is made. If the surfaces are formed, the forms shall be removed and the concrete sprayed lightly with water before the cover is applied.

- C. When concrete surfaces are to receive applied finishes of materials, all curing compounds shall be checked for compatibility with other material to be applied to the concrete surfaces before application.

### 3.08 CONCRETE FINISHES

- A. All poured joints, voids, honeycombs and other imperfections shall be patched within the same working day that forms are removed.
- B. Troweled Finish:
  - 1. Troweled finish shall be applied to the surface of all floors unless ceramic tile, quarry tile or pavers are called for on finish schedule.
  - 2. Floor slabs shall be screened to an even surface by the use of straight-edge and screeding strips accurately set to the proper grade. The concrete shall be floated with a wood float in a manner which will compact it and produce a surface free from depressions or inequalities of any kind. Floors shall be level with a tolerance of 1/8 inch in 10 feet except where drains are indicated. After the concrete has hardened sufficiently to prevent fine materials from working to the top and has been allowed to stand until all water sheen has disappeared, it shall be steel troweled. Final troweling shall be done after the concrete is hard enough that no mortar accumulates on the trowel and a ringing sound is produced as the trowel is drawn over the surface. The drying of the surface moisture before troweling shall proceed naturally and shall not be hastened by the dusting on of dry sand or cement.
- C. Non-slip Finish: All exterior platforms and step treads shall be made non-slippery by application at not less than 1/4 lb. per sq. ft. of aluminum oxide or emery aggregate graded from particles retained on a #50 mesh screen to particles passing an 1/8 inch screen placed during the finishing process. Abrasive aggregate shall be sprinkled by hand as soon as the freshly placed cement will support the weight of workmen and floated into the surface.
- D. Unfinished Slabs: Depressed slab areas to receive ceramic quarry tile or pavers shall be finished to remove all laitance and to leave a slightly roughened, surface to insure bond. The surface of the slab shall not vary in any direction more than 1/8 inch when tested with a ten foot straight edge. The straight edge shall be lapped one half its length as the test is being made.

### 3.09 CONCRETE FLOOR HARDENER

- A. All concrete floor slabs shall be cured with concrete floor hardener, "Clear Bond", as manufactured by Guardian Chemical, "Triple-Cure" by Cobra Chemicals, or "Sealtight Cs-309 by W.R. Meadows. The floor hardener shall be applied in strict accordance with the manufacturer's recommendations.
- B. Walks shall be tooled, full 1 inch deep into separate slabs as indicated. Surface edges of each slab shall be rounded to approximately 1/4 inch radius.
- C. Final finish shall be a medium or light broom finish and all tool marks completely removed.